

### Instructions for Riser Numbers:

**804144** Riser Package, 30-5

**804147** Riser Package, 36-5

**804386** Riser Package, 48-5

**804389** Riser Package, 60-5

**804145** Riser Package, 30-10

**804170** Riser Package, 36-10

**804387** Riser Package, 48-10

**804390** Riser Package, 60-10

**804146** Riser Package, 30-20

**804171** Riser Package, 36-20

**804388** Riser Package, 48-20

**804391** Riser Package, 60-20

### ⚠ WARNING

- DISCONNECT ELECTRIC POWER TO UNIT BEFORE SERVICING AND/OR ACCESSING COMPONENTS.
- SHUT OFF GAS SUPPLY TO UNIT BEFORE SERVICING AND/OR ACCESSING COMPONENTS.

### ⚠ CAUTION

- WEAR GLOVES WHEN HANDLING SHEET METAL PARTS. THERE MAY BE SHARP EDGES.

**Tools Required:** Power Screwdriver w/ #2 Phillips bit.

### Parts Included:

- 1 Riser Front Panel
- 1 Riser Back Panel
- 1 Riser Left Support
- 1 Riser Right Support
- 1 Center Support
- 21 #8 x 3/8" Modified Truss Screws
- 4 Shoulder Screws (20" Risers Only)
- 1 Riser Shelf (20" Risers Only)

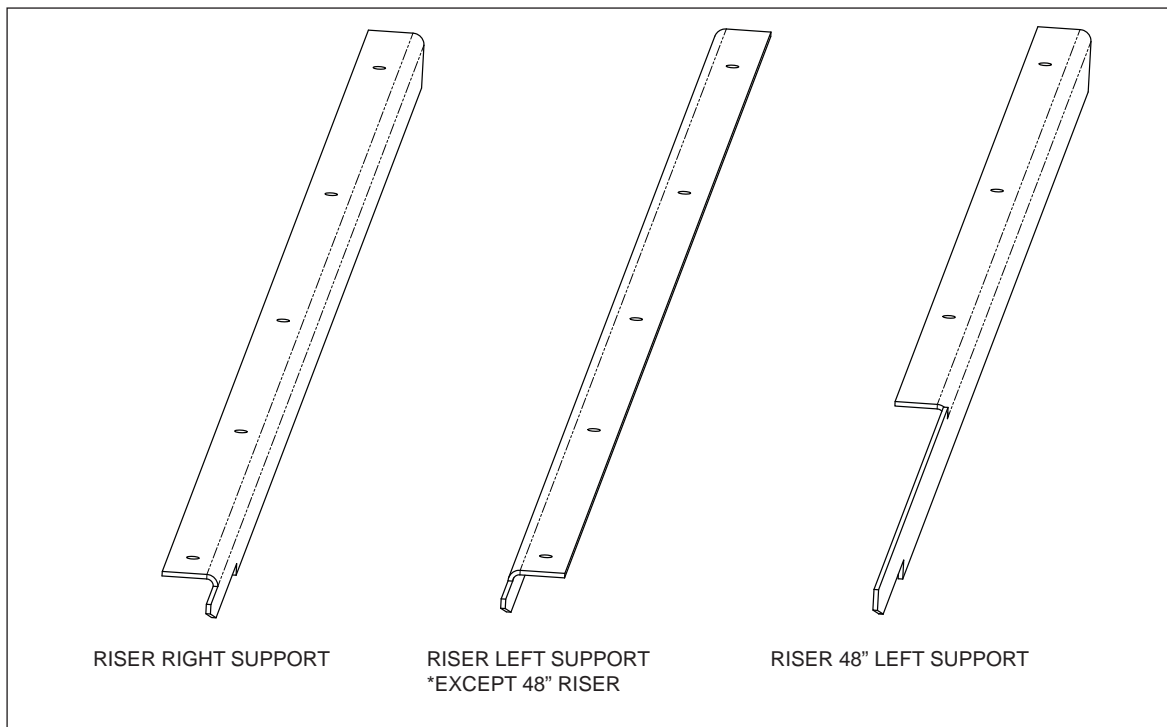

Illustration 1

### Assembling Riser:

1. Lay front panel on work surface cosmetic side down. Remove protective covering from back side of riser front panel.
2. Attach side support legs inside of riser front panel. (See illustration 1 for proper orientation) (shown as they should appear when laying on back of front panel)
3. Remove backing from the double sided tape on the center support bracket flanges. (See illustration 2)
4. Align center support bracket with center mounting hole on rear of front panel. Verify that center support bracket aligns vertically prior to adhering VHB tape to rear of front panel.

**NOTE:** Proper alignment is important prior to securing tape to back side of

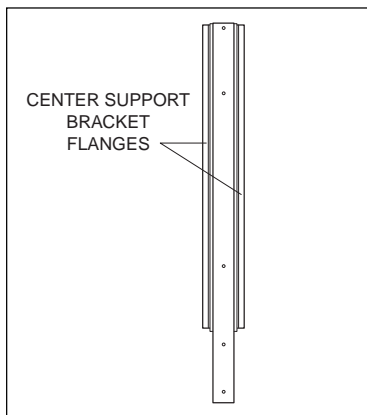

Illustration 2

front panel.

5. Slide back panel inside of front panel mounting flanges. (See illustration 3) Align back panel center notch with front panel and center support bracket mounting hole.
6. Continue installing finishing screws along center support bracket and front panel mounting flanges.

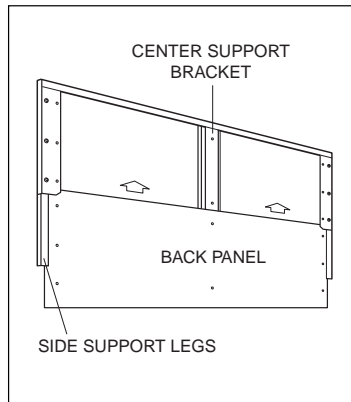

Illustration 3

### Attaching Riser to Range:

1. Verify that all packaging material has been removed from riser assembly and all packaging residues have been cleaned from stainless steel surface.
2. Remove the Island Trim that is factory installed on the range by extracting the screw from each side back and lifting up.
3. Remove screws that fasten the side panel to the back side of the range.
4. Slide riser side support legs inside of range outer side panels until bottom of riser assembly is flush with the side panel. See illustration 4. Verify that center support bracket and side support legs align with mounting holes.
5. Align center support bracket with range back panel mounting holes and install screws (wait to tighten them until after step 6).
6. Attach riser support legs to range side panel through unused holes at back of range. (See illustration 4) Side panels screws can now be reinstalled and tighten all screws from steps 5 & 6.

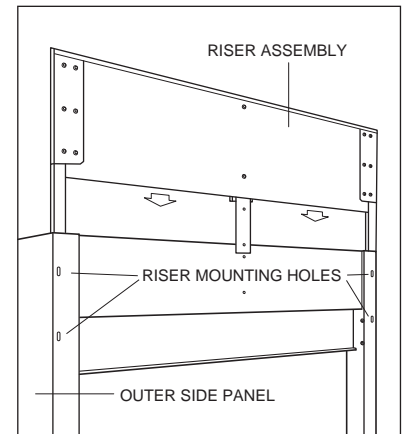

Illustration 4

### Shelf Install 20" Riser Only:

1. Once riser assembly is installed onto range, attach 4 (2 on each side) shoulder screws in front panel assembly.
2. Remove protective packaging material from shelf. Align keyhole slots on back side of shelf assembly with two shoulder screws on the right side of front panel and two shoulder screws on left side of front panel assembly.
3. Slide shelf assembly into place and tighten shoulder screws if necessary. (See illustration 5)

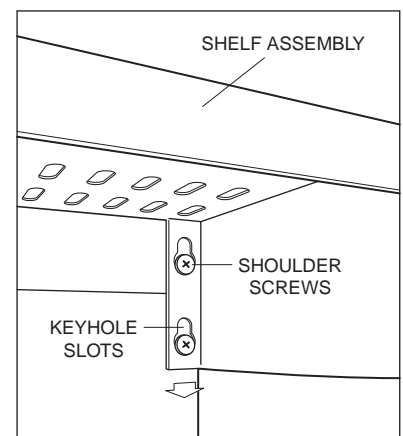

Illustration 5