



810 WEST WASHINGTON BOULEVARD  
CHICAGO, IL 60607

8566 KRUM AVENUE  
GALESBURG, MI 49053

KALAMAZOOGOURMET.COM  
+1.800.868.1699

## K42DB Built-In Gas Grill



### PRODUCT FEATURES

- 36" x 22" (792 square inches) of primary grilling surface
- Three primary burners, 23,000 BTUs each (LP)
- Natural gas, bulk liquid propane or 20-pound liquid propane cylinder (with ventilated base cabinet)
- Rotisserie system with infrared burner; motor mounted in chassis
- Electronic control bezels with flame sensor LED indicators
- Interior task lighting
- Three-position warming rack with stowage
- Standard heavy duty laser-cut cooking surfaces
- Convenient cleanout system with three, separate, one-inch-deep trays
- Marine-grade stainless steel available

Overall Width / Installation Width	44.25 in (1124 mm) / 42 in (1067 mm)
Overall Depth / Installation Depth	30.5 in (776 mm) / MIN. 24.25 in (616 mm); MAX. 25.375 in (645 mm)
Overall Height / Above Counter Height	29.5 in (749 mm) / 18.125 in (461 mm)
Approximate Product Weight	380 lb (172 kg)
Gas Requirements	<b>Natural Gas:</b> 1/2" (13 mm) male NPT connection. 10 ft. (305 cm) gas hose with quick disconnect provided. Gas service line to deliver 7 i.w.c. at grill location. See BTU information below for pipe sizing.
	<b>Bulk Propane:</b> 1/2" (13 mm) male NPT connection. 10 ft. (305 cm) gas hose with quick disconnect provided. Gas service line to deliver 11 i.w.c. at grill location. See BTU information below for pipe sizing.
	<b>Propane Cylinder:</b> 20-pound (9 kg) propane cylinder with provided 2 ft. (61 cm) gas hose with dual regulator. Requires an appropriately-ventilated cylinder enclosure or optional Kalamazoo base cabinet K-DBC42-LVP
Electrical Requirements	120VAC/60Hz Includes 1 ft. (30.5 cm) 3-prong grounded power cord.
Maximum AMP usage	3 amps

Ensure proper gas pipe sizing. Diameter and length of the supply pipe may limit the pressure and BTU delivery.

For outdoor use only. Do not build the grill into a combustible enclosure. Maintain at least 6 inches (153 mm) of clearance between the sides and back of the grill and any combustible surface, or use an insulating surround available from Kalamazoo. Never place the grill underneath an overhead combustible structure or surface. Do not place the grill in a location where the rear hood openings are likely to be exposed to a strong wind.

High altitude kit available.

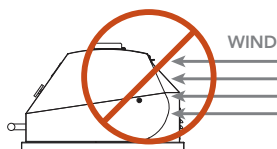

Do not place the grill in a location where the rear hood openings are likely to be exposed to strong wind. A wind break wall is recommended for installations where the prevailing wind may be a problem.

**WARNING:** This product can expose you to chemicals including nickel, which are known to the State of California to cause cancer, and lead, which is known to the State of California to cause birth defects or other reproductive harm. For more information go to [www.P65Warningsca.gov](http://www.P65Warningsca.gov)



810 WEST WASHINGTON BOULEVARD  
CHICAGO, IL 60607

8566 KRUM AVENUE  
GALESBURG, MI 49053

KALAMAZOOGOURMET.COM  
+1.800.868.1699

# K42DB Built-In Gas Grill

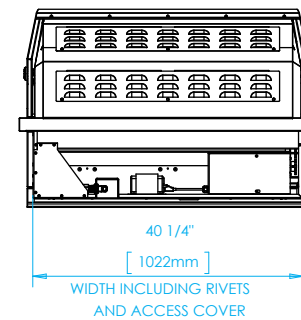
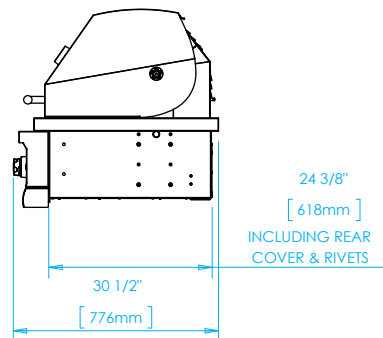
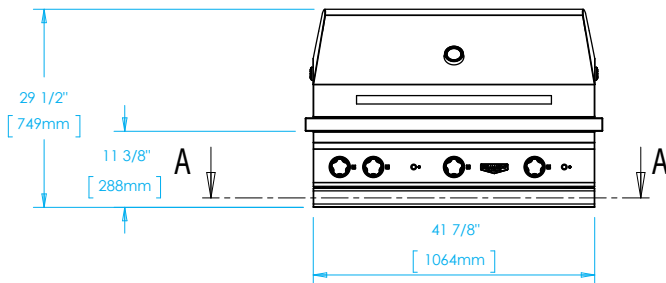
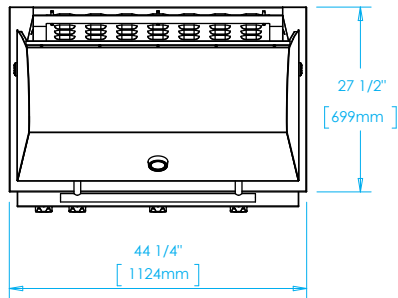
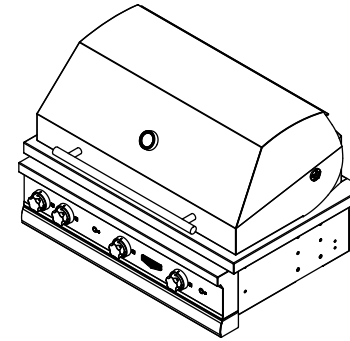
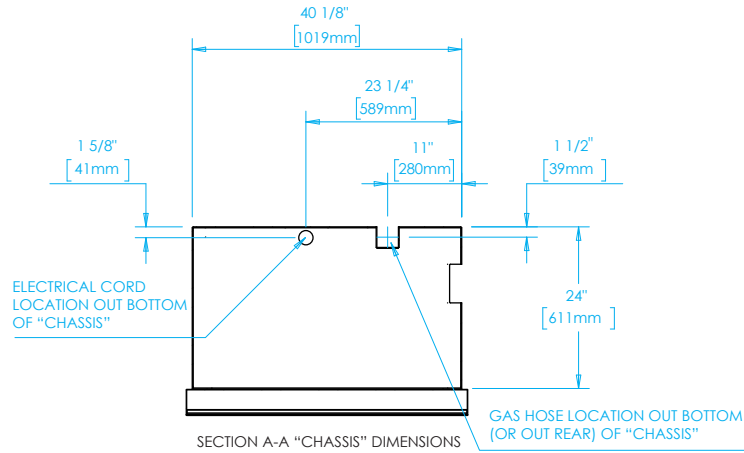



810 WEST WASHINGTON BOULEVARD  
CHICAGO, IL 60607

8566 KRUM AVENUE  
GALESBURG, MI 49053

KALAMAZOOGOURMET.COM  
+1.800.868.1699

## K42DB Built-In Gas Grill

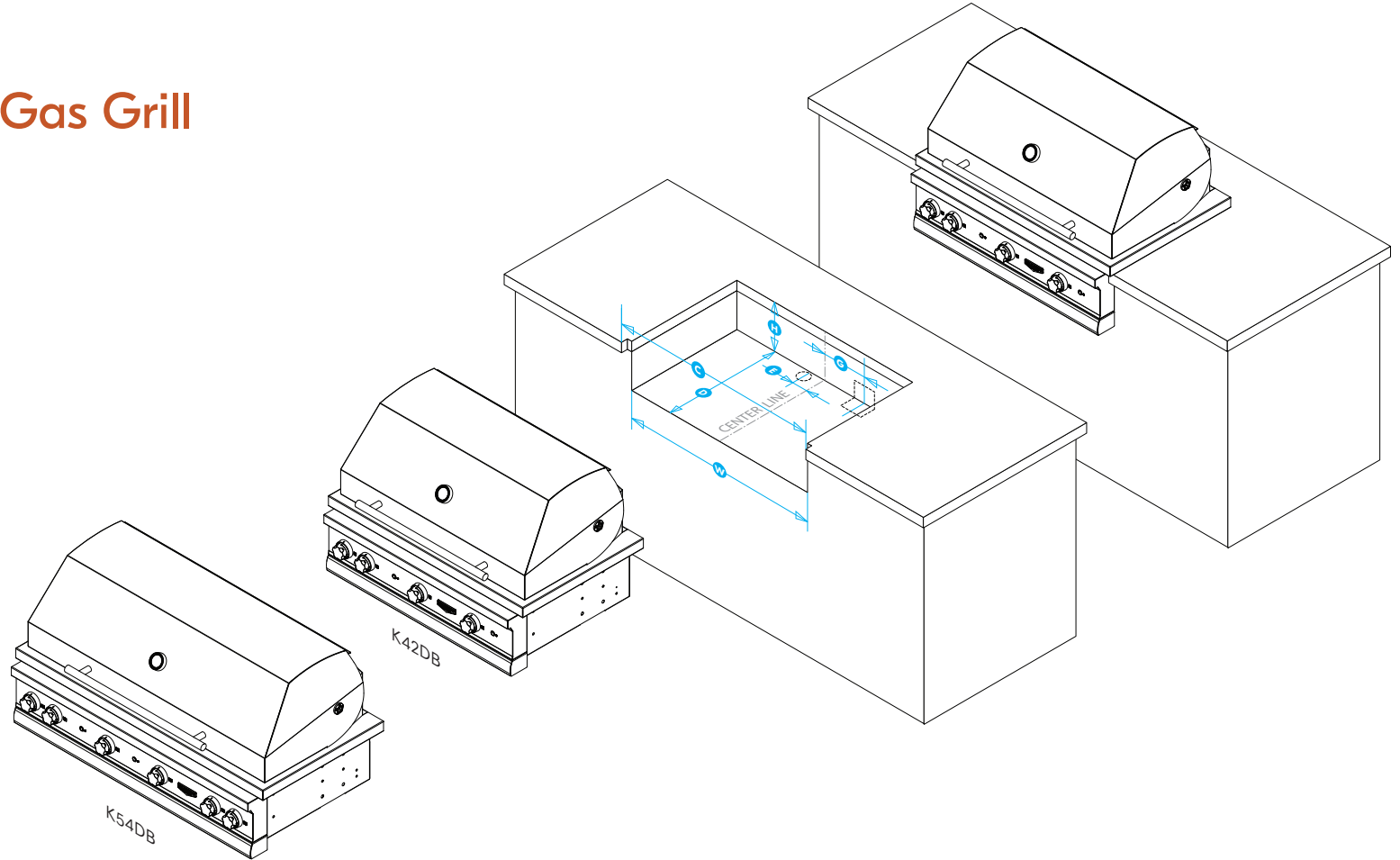

DIMENSION	42-INCH GRILL HEAD (K42DB)		54-INCH GRILL HEAD (K54DB)		NOTES
	MINIMUM	MAXIMUM	MINIMUM	MAXIMUM	
<b>W</b> PRIMARY CUTOUT WIDTH	40.25" / 1023 mm	41.5" / 1054 mm	52.25" / 1328 mm	53.5" / 1359 mm	K42DB MAIN CHASIS IS 40.125" / 1020 mm WIDE K54DB MAIN CHASIS IS 52.125" / 1324 mm WIDE
<b>H</b> PRIMARY CUTOUT HEIGHT	10" / 254 mm	11.675" / 297 mm	10" / 254 mm	11.675" / 297 mm	MAIN CHASIS IS 10" / 254 mm TALL
<b>D</b> PRIMARY CUTOUT DEPTH	24.25" / 616 mm	25.375" / 645 mm	24.25" / 616 mm	25.375" / 645 mm	FROM FACE OF STRUCTURE, NOT INCLUDING COUNTERTOP OVERHANG
<b>C</b> FRONT COUNTERTOP NOTCH WIDTH	42" / 1067 mm	NA	54" / 1372 mm	NA	REQUIRED IF THERE IS A FRONT COUNTERTOP OVERHANG
<b>G</b> GAS HOSE ENTRANCE CENTER LINE	31" / 788 mm	NA	11 in / 280 mm	NA	5" / 127mm OPENING FOR GAS CONNECTION. HOSE MAY PASS THROUGH REAR OR BOTTOM AS NEEDED
<b>E</b> ELECTRICAL CORD PASS-THROUGH	31" / 788 mm	NA	5" / 127 mm	NA	4" / 102mm OPENING REQUIRED FOR GROUNDED ELECTRICAL EXTENSION CORD CENTERED 2" / 51mm TO 3" / 76mm FROM REAR OF CUTOUT