

Haier

Submittals

FlexFit Pro Single Series

Rev. May 2019

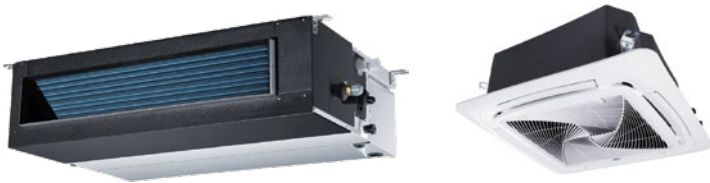

1U24LP2VHA / AW24LP2VHA

1U24LP2VHA / AM24LP2VHA

1U24LP2VHA / AL24LP2VHA

1U36LP2VHA / AW36LP2VHA

1U36LP2VHA / AM36LP2VHA

1U36LP2VHA / AL36LP2VHA

1U48LP2VHA / AM48LP2VHA

1U48LP2VHA / AL48LP2VHA



For more information visit us:
www.Haierductless.com
www.Haierductlesshelp.com

Revision History

Rev. April 2017 - Edition release

Rev. May 2017 - AM24LP2VHA dimension diagram correction; AL48LP2VHA cooling capacity correction.

Rev. April 2018 - Added Motor Ratings (all models), Condensate Pump Lift (AM24LP2VHA, AM36LP2VHA, AM48LP2VHA, AL24LP2VHA, AL36LP2VHA, AL48LP2VHA); Maximum ESP (AM24LP2VHA, AM36LP2VHA, AM48LP2VHA); Dimension diagram updates (AM24LP2VHA, AL models).

Rev. Feb 2019 - Corrected controller compatibility for 1U24LP2VHA / AM24LP2VHA, 1U36LP2VHA / AM36LP2VHA, 1U48LP2VHA / AM48LP2VHA

Rev. May 2019 - Accessories & electrical requirement update.

Haier FlexFit Pro Single Submittal

24000 BTU/HR WALL MOUNTED INVERTER DRIVEN HEAT PUMP SYSTEM

1U24LP2VHA / AW24LP2VHA

Job Name: _____

Purchaser: _____

Submitted To: _____

Construction: _____

Reference: _____

Approval: _____

Date: _____

Submitted By: _____

Unit: _____

Drawing #: _____



Accessories

Remote Controller

Ships with YR-HG

Wired Controller

Compatible with wired controllers YR-E17, YR-E16B, and QACT17A. All wired controllers require interface kit WK-B.

WiFi

Compatible with WiFi adapter QAWF01A.

Wind Baffle

Uses wind baffle QAWB42A



For more information visit us:
www.Haierductless.com
www.Haierductlesshelp.com

Electrical Requirement

Power Supply	208/230V, 1 Phase, 60 HZ
Operating Voltage Range	187~253 VAC
Recommended Fuse/Breaker Size	25A
MCA	21A

Connecting cable to indoor units must be 14/4 AWG unshielded stranded copper. Cable must be ran continuous, without splicing.

Operating Range

Cooling	0~115°F (-18~46°C)
Heating	-4~75°F (-20~24°C)

Cooling Performance

Rated Cooling Capacity	24,000 BTU
Cooling Capacity Range	6,800~24,100 BTU
Rated Power input	2,182 W
SEER	17.0
EER	10.0

Heating Performance

Rated Heating Capacity	27,000 BTU
Heating Capacity Range	6,800~34,100 BTU
HSPF	10.0

Pipe Length

Minimum Pipe Length	6 ft
Maximum Pipe Length	165 ft
Maximum Pipe Height Difference	100 ft
Connection	3/8" (Discharge) 5/8" (Suction) Flare



Haier FlexFit Pro Single Submittal

24000 BTU/HR WALL MOUNTED INVERTER DRIVEN HEAT PUMP SYSTEM

1U24LP2VHA / AW24LP2VHA

Indoor Unit	
Uncrated Dimension (HxWxD)	14 3/8 x 43 7/8 x 9 5/8 in (366 x 1115 x 243 mm)
Crated (HxWxD)	16 1/2 x 47 1/2 x 13 1/2 in (418 x 1206 x 342 mm)
Airflow CFM (Turbo/High/Med/Low/Quiet)	710/650/560/440/410
Indoor Sound Level dB (Turbo/High/Med/Low/Quiet)	49/47/42/36/34
Motor Rating (HP)	0.094
Heat Exchanger Fin Type	Blue Fin
Weight (Ship/Net)	45.4/37.5 lbs

Outdoor Unit	
Compressor	DC inverter Driven Rotary
Uncrated Dimension (HxWxD)	38 x 37 3/8 x 14 5/8 in (965 x 950 x 370 mm)
Crated (HxWxD)	43 1/8 x 41 3/8 x 17 3/4 in (1095 x 1050 x 450 mm)
Outdoor Sound Rating dB	47
Heat Exchanger Fin Type	Blue Fin
Weight (Ship/Net)	202.8/176.4 lbs
Factory Refrigerant Charge	R-410A (88.2 oz)

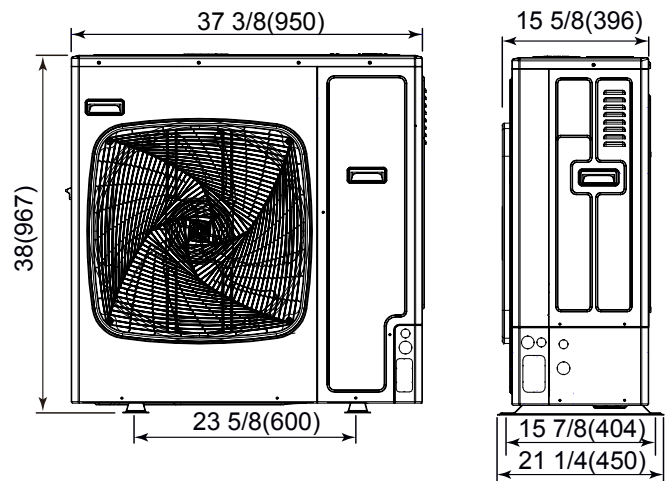
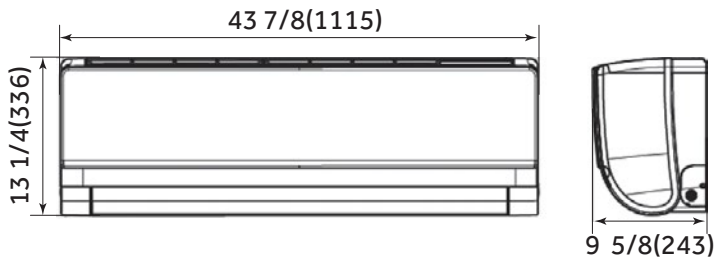

Heating Capacity Data

Outdoor Air Temp DB	Indoor Set Temperature					
	60°F (16°C)		70°F (21°C)		77°F (25°C)	
	Maximum Heating Capacity (Btu/h)	Power Usage (w)	Max Heating Capacity (Btu/h)	Power Usage (w)	Max Heating Capacity (Btu/h)	Power Usage (w)
-4°F (-20°C)	20,270	2,090	18,530	2,320	17,100	2,620
5°F (-15°C)	21,920	2,150	20,030	2,390	18,490	2,700
17°F (-8°C)	24,270	2,190	22,180	2,440	20,480	2,760
47°F (8°C)	29,760	2,240	27,200	2,490	25,110	2,810

Capacity and power usage are measured under the assumption of indoor humidity of 46%

Cooling Capacity Data

Outdoor Air Temp DB	Indoor Set Temperature					
	70°F (21°C)		75°F (24°C)		80°F (27°C)	
	Total Capacity (Btu/h)	Power Usage (w)	Total Capacity (Btu/h)	Power Usage (w)	Total Capacity (Btu/h)	Power Usage (w)
0°F (-18°C)	22,780	1,260	23,380	1,320	24,080	1,370
14°F (-10°C)	23,210	1,490	23,830	1,550	24,540	1,610
32°F (0°C)	24,780	1,650	25,450	1,700	26,130	1,780
50°F (10°C)	25,620	1,780	26,320	1,840	27,020	1,930
65°F (18°C)	25,120	1,860	25,780	1,940	26,550	2,010
75°F (24°C)	24,570	1,970	25,220	2,060	25,970	2,130
85°F (29°C)	23,950	2,080	24,590	2,170	25,320	2,250
95°F (35°C)	22,890	2,140	23,500	2,240	24,200	2,320
105°F (41°C)	21,620	2,190	22,190	2,290	22,850	2,370
115°F (46°C)	20,330	2,230	20,870	2,340	21,490	2,420

Capacity and power usage are measured under the assumption of indoor humidity of 46%

Haier FlexFit Pro Single Submittal

24000 BTU/HR HIGH STATIC DUCTED INDOOR INVERTER DRIVEN HEAT PUMP SYSTEM 1U24LP2VHA / AM24LP2VHA

Job Name: _____

Purchaser: _____

Submitted To: _____

Construction: _____

Reference: _____

Approval: _____

Date: _____

Submitted By: _____

Unit: _____

Drawing #: _____



Accessories

Remote Controller

Ships with YR-E17

Wired Controller

Compatible with wired controllers YR-E16B and QACT17A

Wind Baffle

Uses wind baffle QAWB38A

Electrical Requirement	
Power Supply	208/230V, 1 Phase, 60 HZ
Operating Voltage Range	187~253 VAC
Recommended Fuse/Breaker Size	25A
MCA	21A

Connecting cable to indoor units must be 14/4 AWG unshielded stranded copper. Cable must be ran continuous, without splicing.

Operating Range	
Cooling	0~115°F (-18~46°C)
Heating	-4~75°F (-20~24°C)

Cooling Performance	
Rated Cooling Capacity	24,000 BTU
Cooling Capacity Range	6,800~30,700 BTU
Rated Power input	2,182 W
SEER	17.0
EER	11.0

Heating Performance	
Rated Heating Capacity	26,500 BTU
Heating Capacity Range	6,800~34,100 BTU
HSPF	11.0

Pipe Length	
Minimum Pipe Length	6 ft
Maximum Pipe Length	165 ft
Maximum Pipe Height Difference	100 ft
Connection	3/8" (Discharge) 5/8" (Suction) Flare



For more information visit us:
www.Haierductless.com
www.Haierductlesshelp.com



Haier FlexFit Pro Single Submittal

24000 BTU/HR HIGH STATIC DUCTED INDOOR INVERTER DRIVEN HEAT PUMP SYSTEM

1U24LP2VHA / AM24LP2VHA

Indoor Unit	
Uncrated Dimension (HxWxD)	9 7/8 x 41 3/8 x 28 3/8 in (250 x 1050 x 720 mm)
Crated (HxWxD)	13 3/8 x 46 1/8 x 33 7/8 in (340 x 1170 x 860 mm)
Maximum ESP (IWC)	0.60
Airflow CFM (Turbo/High/Med/Low/Quiet)	845/670/530/470
Indoor Sound Level dB (Turbo/High/Med/Low/Quiet)	38/35/32/29
Motor Rating (HP)	0.362
Heat Exchanger Fin Type	Blue Fin
Condensate Pump	Included - 27.5 in Lift
Weight (Ship/Net)	81.1/68.8 lbs

Outdoor Unit	
Compressor	DC inverter Driven Rotary
Uncrated Dimension (HxWxD)	38 x 37 3/8 x 14 5/8 in (965 x 950 x 370 mm)
Crated (HxWxD)	43 1/8 x 41 3/8 x 17 3/4 in (1095 x 1050 x 450 mm)
Outdoor Sound Rating dB	47
Heat Exchanger Fin Type	Blue Fin
Weight (Ship/Net)	202.8/176.4 lbs
Factory Refrigerant Charge	R-410A (88.2 oz)

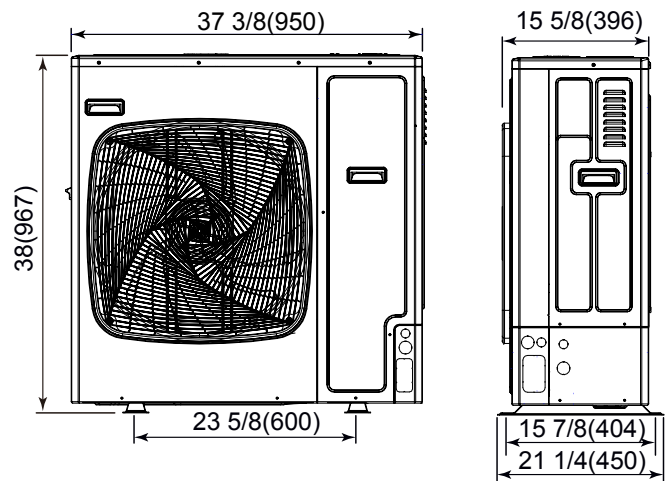
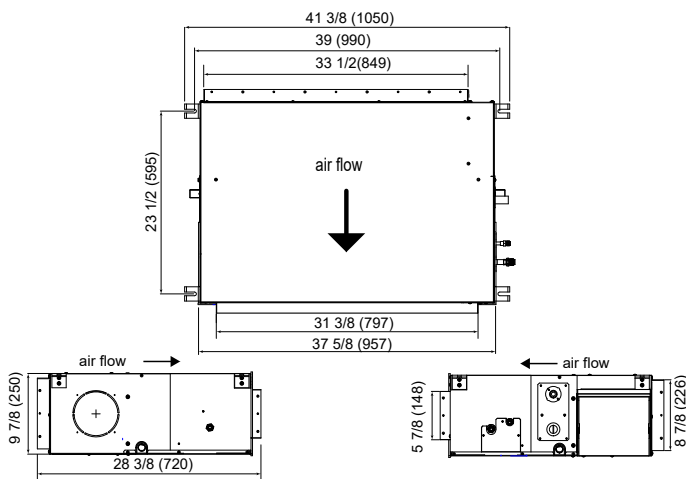

Heating Capacity Data

Outdoor Air Temp DB	Indoor Set Temperature					
	60°F (16°C)		70°F (21°C)		77°F (25°C)	
	Maximum Heating Capacity (Btu/h)	Power Usage (w)	Max Heating Capacity (Btu/h)	Power Usage (w)	Max Heating Capacity (Btu/h)	Power Usage (w)
-4°F (-20°C)	16,220	1,920	15,780	1,980	15,020	1,920
5°F (-15°C)	17,380	1,980	16,890	2,100	16,450	2,180
17°F (-8°C)	21,270	2,230	21,010	2,320	20,780	2,300
47°F (8°C)	28,200	2,450	27,300	2,570	26,850	2,610

Capacity and power usage are measured under the assumption of indoor humidity of 46%

Cooling Capacity Data

Outdoor Air Temp DB	Indoor Set Temperature					
	70°F (21°C)		75°F (24°C)		80°F (27°C)	
	Total Capacity (Btu/h)	Power Usage (w)	Total Capacity (Btu/h)	Power Usage (w)	Total Capacity (Btu/h)	Power Usage (w)
0°F (-18°C)	22,450	1,430	23,270	1,870	24,110	1,870
14°F (-10°C)	23,250	1,680	24,100	1,900	24,270	1,910
32°F (0°C)	24,970	1,780	25,680	1,990	26,320	2,020
50°F (10°C)	26,080	1,870	26,880	2,060	27,120	2,100
65°F (18°C)	25,710	2,010	26,510	2,130	26,760	2,180
75°F (24°C)	25,200	2,080	26,020	2,180	26,220	2,210
85°F (29°C)	24,310	2,140	25,130	2,270	25,400	2,300
95°F (35°C)	22,820	2,190	23,610	2,300	24,600	2,330
105°F (41°C)	22,020	2,280	22,810	2,310	23,100	2,370
115°F (46°C)	20,320	2,350	21,160	2,390	21,900	2,450

Capacity and power usage are measured under the assumption of indoor humidity of 46%

Haier FlexFit Pro Single Submittal

24000 BTU/HR 3x3 LARGE CASSETTE INVERTER DRIVEN HEAT PUMP SYSTEM 1U24LP2VHA / AL24LP2VHA

Job Name: _____

Purchaser: _____

Submitted To: _____

Construction: _____

Reference: _____

Approval: _____

Date: _____

Submitted By: _____

Unit: _____

Drawing #: _____



Accessories

Remote controller

Ships with YR-HBS01

Wired Thermostat

Compatible with wired controllers YR-E17, YR-E16B, and QACT17A.

Wind Baffle

Uses wind baffle QAWB38A

Panel

PB-950KB is required to complete the installation and it must be ordered separately



For more information visit us:
www.Haierductless.com
www.Haierductlesshelp.com

Electrical Requirement

Power Supply	208/230V, 1 Phase, 60 HZ
Operating Voltage Range	187~253 VAC
Recommended Fuse/Breaker Size	25A
MCA	21A

Connecting cable to indoor units must be 14/4 AWG unshielded stranded copper. Cable must be ran continuous, without splicing.

Operating Range

Cooling	0~115°F (-18~46°C)
Heating	-4~75°F (-20~24°C)

Cooling Performance

Rated Cooling Capacity	24,000 BTU
Cooling Capacity Range	6,800~27,000 BTU
Rated Power input	2,087 W
SEER	17.0
EER	11.5

Heating Performance

Rated Heating Capacity	27,300 BTU
Heating Capacity Range	6,800~30,500 BTU
HSPF	10.0

Pipe Length

Minimum Pipe Length	6 ft
Maximum Pipe Length	165 ft
Maximum Pipe Height Difference	100 ft
Connection	3/8" (Discharge) 5/8" (Suction) Flare



Haier FlexFit Pro Single Submittal

24000 BTU/HR 3x3 LARGE CASSETTE INVERTER DRIVEN HEAT PUMP SYSTEM 1U24LP2VHA / AL24LP2VHA

Indoor Unit	
Uncrated Dimension (HxWxD)	9 5/8 x 33 1/8 x 33 1/8 in (246 x 840 x 840 mm)
Crated (HxWxD)	12 1/4 x 39 x 39 in (310 x 990 x 990 mm)
Panel Uncrated Dimension (HxWxD)	2 x 37 3/8 x 37 3/8 in (50 x 950 x 950 mm)
Panel Crated (HxWxD)	4 3/8 x 39 3/8 x 39 3/8 in (110 x 1000 x 1000 mm)
Airflow CFM (Turbo/High/Med/Low/Quiet)	740/630/480/400
Indoor Sound Level dB (Turbo/High/Med/Low/Quiet)	36/33/29/26
Motor Rating (HP)	0.161
Heat Exchanger Fin Type	Blue Fin
Condensate Pump	Included - 47.2 in Lift
Weight (Ship/Net)	79.4/68.3 lbs

Outdoor Unit	
Compressor	DC inverter Driven Rotary
Uncrated Dimension (HxWxD)	38 x 37 3/8 x 14 5/8 in (965 x 950 x 370 mm)
Crated (HxWxD)	43 1/8 x 41 3/8 x 17 3/4 in (1095 x 1050 x 450 mm)
Outdoor Sound Rating dB	47
Heat Exchanger Fin Type	Blue Fin
Weight (Ship/Net)	202.8/176.4 lbs
Factory Refrigerant Charge	R-410A (88.2 oz)

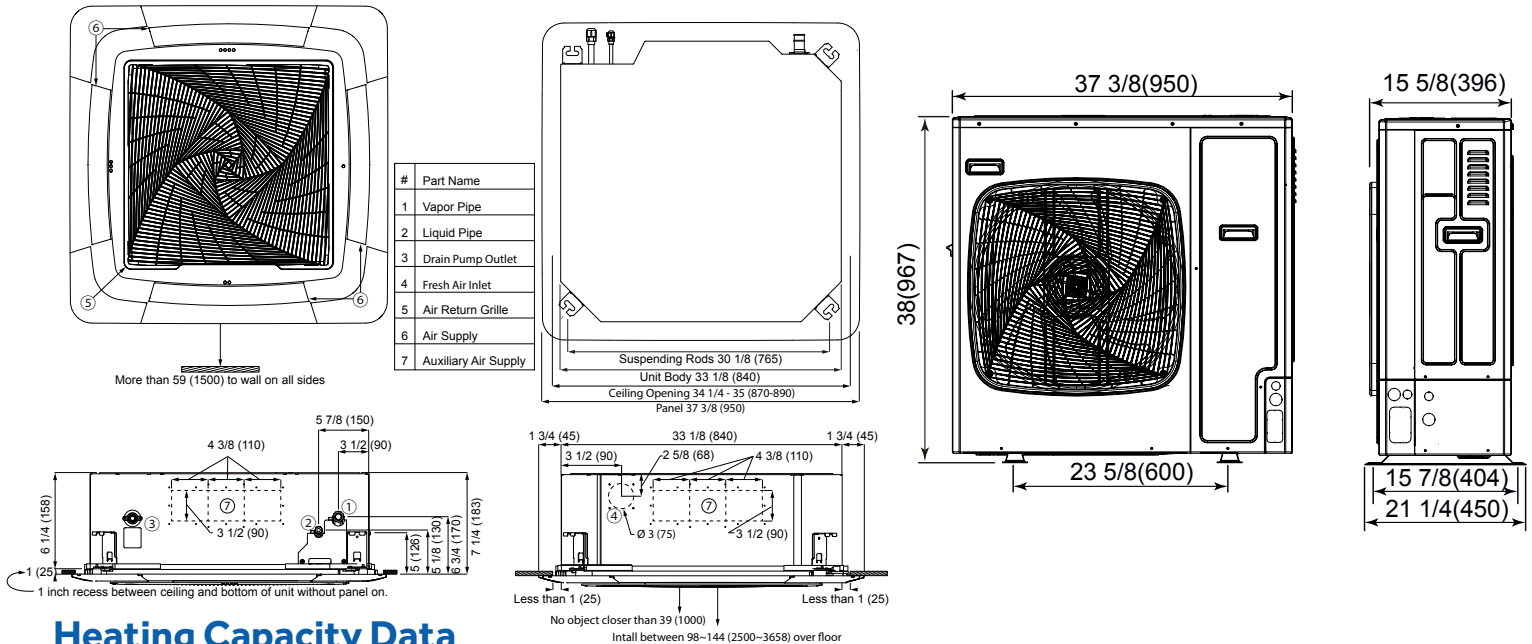

Heating Capacity Data

Outdoor Air Temp DB	Indoor Set Temperature					
	60°F (16°C)		70°F (21°C)		77°F (25°C)	
	Maximum Heating Capacity (Btu/h)	Power Usage (w)	Max Heating Capacity (Btu/h)	Power Usage (w)	Max Heating Capacity (Btu/h)	Power Usage (w)
-4°F (-20°C)	15,450	1,910	15,030	1,970	14,620	1,900
5°F (-15°C)	16,780	1,970	16,520	2,090	15,780	2,170
17°F (-8°C)	20,210	2,220	20,030	2,310	19,560	2,290
47°F (8°C)	27,990	2,450	27,110	2,560	26,640	2,610

Cooling Capacity Data

Outdoor Air Temp DB	Indoor Set Temperature					
	70°F (21°C)		75°F (24°C)		80°F (27°C)	
	Total Capacity (Btu/h)	Power Usage (w)	Total Capacity (Btu/h)	Power Usage (w)	Total Capacity (Btu/h)	Power Usage (w)
0°F (-18°C)	22,340	1,440	23,150	1,850	24,020	1,860
14°F (-10°C)	23,140	1,680	24,020	1,870	24,180	1,900
32°F (0°C)	24,890	1,770	25,760	1,990	26,110	1,990
50°F (10°C)	25,960	1,870	26,600	2,040	27,010	2,090
65°F (18°C)	25,600	2,010	26,410	2,110	26,620	2,160
75°F (24°C)	25,090	2,060	25,890	2,160	26,120	2,210
85°F (29°C)	24,210	2,120	25,010	2,240	25,280	2,290
95°F (35°C)	22,680	2,150	23,520	2,290	24,280	2,300
105°F (41°C)	21,910	2,170	22,620	2,300	22,980	2,350
115°F (46°C)	20,220	2,210	21,020	2,370	21,780	2,410

Capacity and power usage are measured under the assumption of indoor humidity of 46%

Haier FlexFit Pro Single Submittal

36000 BTU/HR WALL MOUNTED INVERTER DRIVEN HEAT PUMP SYSTEM

1U36LP2VHA / AW36LP2VHA

Job Name: _____

Purchaser: _____

Submitted To: _____

Construction: _____

Reference: _____

Approval: _____

Date: _____

Submitted By: _____

Unit: _____

Drawing #: _____



Accessories

Remote Controller

Ships with YR-HG

Wired Controller

Compatible with wired controllers YR-E17, YR-E16B, and QACT17A. All wired controllers require interface kit WK-B.

WiFi

Compatible with WiFi adapter QAWF01A.

Wind Baffle

Uses wind baffle QAWB38A



For more information visit us:
www.Haierductless.com
www.Haierductlesshelp.com

Electrical Requirement

Power Supply	208/230V, 1 Phase, 60 HZ
Operating Voltage Range	187~253 VAC
Recommended Fuse/Breaker Size	30A
MCA	26A

Connecting cable to indoor units must be 14/4 AWG unshielded stranded copper. Cable must be ran continuous, without splicing.

Operating Range

Cooling	0~115°F (-18~46°C)
Heating	-4~75°F (-20~24°C)

Cooling Performance

Rated Cooling Capacity	35,000 BTU
Cooling Capacity Range	6,200~30,700 BTU
Rated Power input	3,500 W
SEER	17.0
EER	8.6

Heating Performance

Rated Heating Capacity	37,000 BTU
Heating Capacity Range	8,500~41,000 BTU
HSPF	10.0

Pipe Length

Minimum Pipe Length	6 ft
Maximum Pipe Length	165 ft
Maximum Pipe Height Difference	100 ft
Connection	3/8" (Discharge) 5/8" (Suction) Flare



Haier FlexFit Pro Single Submittal

36000 BTU/HR WALL MOUNTED INVERTER DRIVEN HEAT PUMP SYSTEM

1U36LP2VHA / AW36LP2VHA

Indoor Unit	
Uncrated Dimension (HxWxD)	14 3/8 x 51 3/4 x 10 7/8 in (365 x 1316 x 275 mm)
Crated (HxWxD)	18 7/8 x 55 7/8 x 15 7/8 in (478 x 1418 x 402 mm)
Airflow CFM (Turbo/High/Med/Low/Quiet)	720/660/570/450/420
Indoor Sound Level dB (Turbo/High/Med/Low/Quiet)	50/48/44/38/36
Motor Rating (HP)	0.094
Heat Exchanger Fin Type	Blue Fin
Weight (Ship/Net)	55.1/46.3 lbs

Outdoor Unit	
Compressor	DC inverter Driven Rotary
Uncrated Dimension (HxWxD)	38 x 37 3/8 x 14 5/8 in (965 x 950 x 370 mm)
Crated (HxWxD)	43 1/8 x 41 3/8 x 17 3/4 in (1095 x 1050 x 450 mm)
Outdoor Sound Rating dB	52
Heat Exchanger Fin Type	Blue Fin
Weight (Ship/Net)	207.2/180.7 lbs
Factory Refrigerant Charge	R-410A (88.2 oz)

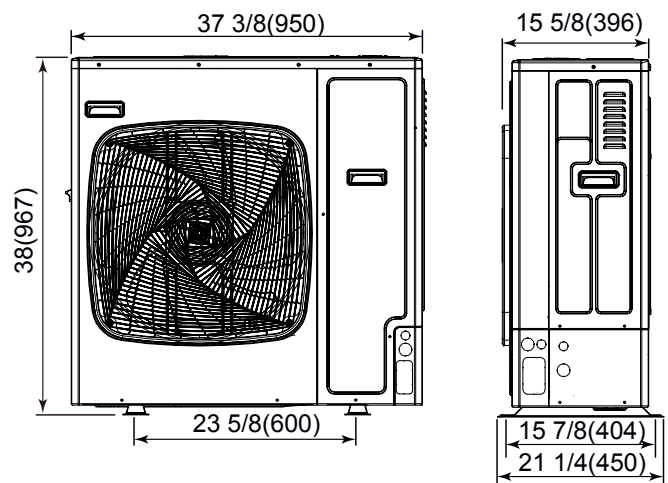
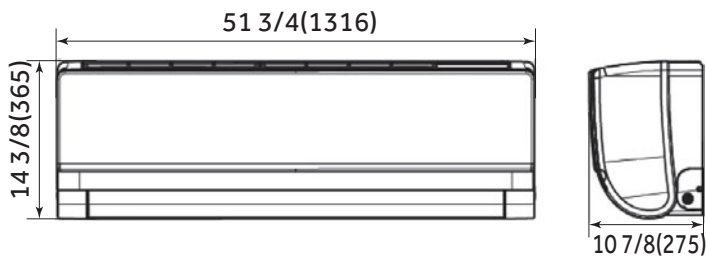

Heating Capacity Data

Outdoor Air Temp DB	Indoor Set Temperature					
	60°F (16°C)		70°F (21°C)		77°F (25°C)	
	Maximum Heating Capacity (Btu/h)	Power Usage (w)	Max Heating Capacity (Btu/h)	Power Usage (w)	Max Heating Capacity (Btu/h)	Power Usage (w)
-4°F (-20°C)	28,180	3,230	25,760	3,590	23,780	4,060
5°F (-15°C)	31,590	3,290	28,880	3,660	26,660	4,140
17°F (-8°C)	34,720	3,340	31,740	3,710	29,300	4,190
47°F (8°C)	41,030	3,390	37,510	3,770	34,620	4,260

Capacity and power usage are measured under the assumption of indoor humidity of 46%

Cooling Capacity Data

Outdoor Air Temp DB	Indoor Set Temperature					
	70°F (21°C)		75°F (24°C)		80°F (27°C)	
	Total Capacity (Btu/h)	Power Usage (w)	Total Capacity (Btu/h)	Power Usage (w)	Total Capacity (Btu/h)	Power Usage (w)
0°F (-18°C)	33,250	2,640	34,130	2,760	35,150	2,860
14°F (-10°C)	33,400	2,830	34,290	2,960	35,310	3,070
32°F (0°C)	34,320	3,160	35,280	3,270	36,300	3,380
50°F (10°C)	35,220	3,350	36,120	3,500	37,220	3,610
65°F (18°C)	34,840	3,480	35,760	3,640	36,830	3,770
75°F (24°C)	34,160	3,550	35,060	3,720	36,110	3,850
85°F (29°C)	33,790	3,630	34,680	3,790	35,720	3,930
95°F (35°C)	33,710	3,860	34,600	4,030	35,630	4,180
105°F (41°C)	31,330	3,810	32,160	3,990	33,120	4,130
115°F (46°C)	30,470	3,900	31,280	4,070	32,210	4,220

Capacity and power usage are measured under the assumption of indoor humidity of 46%

Haier FlexFit Pro Single Submittal

36000 BTU/HR HIGH STATIC DUCTED INDOOR INVERTER DRIVEN HEAT PUMP SYSTEM 1U36LP2VHA / AM36LP2VHA

Job Name: _____

Purchaser: _____

Submitted To: _____

Construction: _____

Reference: _____

Approval: _____

Date: _____

Submitted By: _____

Unit: _____

Drawing #: _____



Accessories

Remote Controller

Ships with YR-E17

Wired Controller

Compatible with wired controllers YR-E16B and QACT17A

Wind Baffle

Uses wind baffle QAWB38A

Electrical Requirement	
Power Supply	208/230V, 1 Phase, 60 HZ
Operating Voltage Range	187~253 VAC
Recommended Fuse/Breaker Size	30A
MCA	26A

Connecting cable to indoor units must be 14/4 AWG unshielded stranded copper. Cable must be ran continuous, without splicing.

Operating Range	
Cooling	0~115°F (-18~46°C)
Heating	-4~75°F (-20~24°C)

Cooling Performance	
Rated Cooling Capacity	35,000 BTU
Cooling Capacity Range	8,500~37,500 BTU
Rated Power input	3,500 W
SEER	17.0
EER	10.0

Heating Performance	
Rated Heating Capacity	37,500 BTU
Heating Capacity Range	8,500~41,000 BTU
HSPF	10.5

Pipe Length	
Minimum Pipe Length	6 ft
Maximum Pipe Length	165 ft
Maximum Pipe Height Difference	100 ft
Connection	3/8" (Discharge) 5/8" (Suction) Flare



For more information visit us:
www.Haierductless.com
www.Haierductlesshelp.com



Haier FlexFit Pro Single Submittal

36000 BTU/HR HIGH STATIC DUCTED INDOOR INVERTER DRIVEN HEAT PUMP SYSTEM

1U36LP2VHA / AM36LP2VHA

Indoor Unit	
Uncrated Dimension (HxWxD)	9 7/8 x 59 x 28 3/8 in (250 x 1500 x 720 mm)
Crated (HxWxD)	12 5/8 x 67 3/8 x 34 in (320 x 1710 x 865 mm)
Maximum ESP (IWC)	0.60
Airflow CFM (Turbo/High/Med/Low/Quiet)	1100/950/735/675
Indoor Sound Level dB (Turbo/High/Med/Low/Quiet)	32/28/25/23
Motor Rating (HP)	0.617
Heat Exchanger Fin Type	Blue Fin
Condensate Pump	Included - 27.5 in Lift
Weight (Ship/Net)	130.1/121.3 lbs

Outdoor Unit	
Compressor	DC inverter Driven Rotary
Uncrated Dimension (HxWxD)	38 x 37 3/8 x 14 5/8 in (965 x 950 x 370 mm)
Crated (HxWxD)	43 1/8 x 41 3/8 x 17 3/4 in (1095 x 1050 x 450 mm)
Outdoor Sound Rating dB	52
Heat Exchanger Fin Type	Blue Fin
Weight (Ship/Net)	207.2/180.7 lbs
Factory Refrigerant Charge	R-410A (88.2 oz)

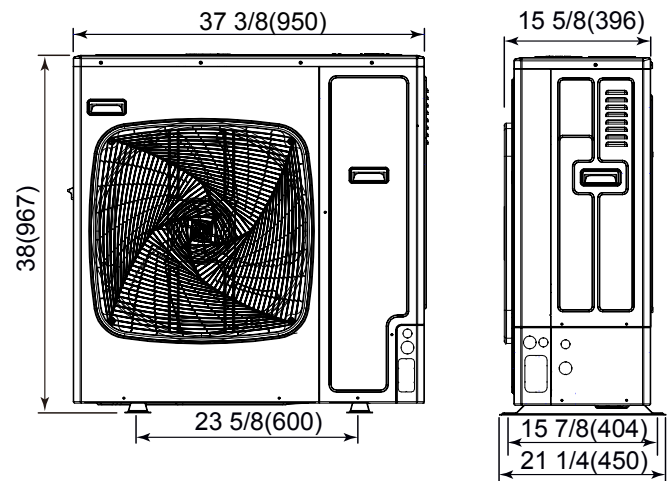
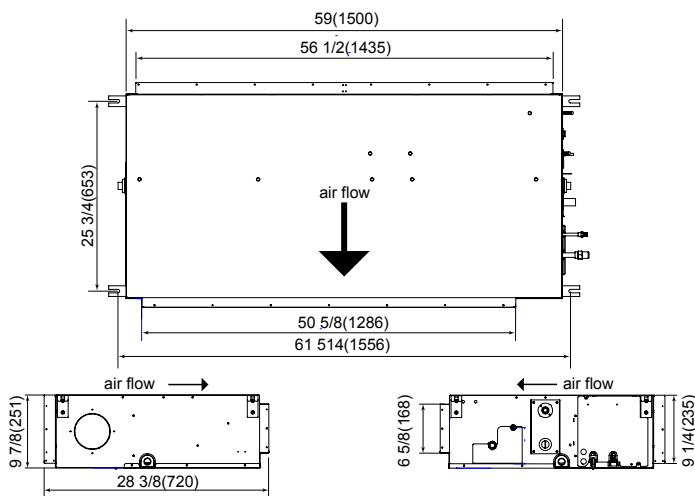

Heating Capacity Data

Outdoor Air Temp DB	Indoor Set Temperature					
	60°F (16°C)		70°F (21°C)		77°F (25°C)	
	Maximum Heating Capacity (Btu/h)	Power Usage (w)	Max Heating Capacity (Btu/h)	Power Usage (w)	Max Heating Capacity (Btu/h)	Power Usage (w)
-4°F (-20°C)	22,100	2,470	21,120	2,610	20,290	2,650
5°F (-15°C)	25,430	2,650	23,140	2,690	21,200	2,730
17°F (-8°C)	31,020	3,310	29,890	3,230	29,310	3,310
47°F (8°C)	38,170	3,510	37,870	3,520	35,560	3,550

Capacity and power usage are measured under the assumption of indoor humidity of 46%

Cooling Capacity Data

Outdoor Air Temp DB	Indoor Set Temperature					
	70°F (21°C)		75°F (24°C)		80°F (27°C)	
	Total Capacity (Btu/h)	Power Usage (w)	Total Capacity (Btu/h)	Power Usage (w)	Total Capacity (Btu/h)	Power Usage (w)
0°F (-18°C)	34,180	2,340	34,960	2,520	35,970	2,530
14°F (-10°C)	34,980	2,540	35,770	2,710	36,350	2,720
32°F (0°C)	35,730	2,710	36,510	2,890	36,720	2,890
50°F (10°C)	36,150	2,880	36,900	3,040	37,110	3,070
65°F (18°C)	35,690	3,010	36,470	3,190	36,780	3,200
75°F (24°C)	35,220	3,130	36,000	3,300	36,420	3,310
85°F (29°C)	35,430	3,210	36,210	3,380	36,010	3,390
95°F (35°C)	34,890	3,310	35,670	3,480	35,890	3,490
105°F (41°C)	34,720	3,700	35,510	3,870	35,730	3,910
115°F (46°C)	31,440	3,580	32,230	3,750	33,240	3,760

Capacity and power usage are measured under the assumption of indoor humidity of 46%

Haier FlexFit Pro Single Submittal

36000 BTU/HR 3x3 LARGE CASSETTE INVERTER DRIVEN HEAT PUMP SYSTEM 1U36LP2VHA / AL36LP2VHA

Job Name: _____

Purchaser: _____

Submitted To: _____

Construction: _____

Reference: _____

Approval: _____

Date: _____

Submitted By: _____

Unit: _____

Drawing #: _____



Accessories

Remote controller

Ships with YR-HBS01

Wired Thermostat

Compatible with wired controllers YR-E17, YR-E16B, and QACT17A.

Wind Baffle

Uses wind baffle QAWB38A

Panel

PB-950KB is required to complete the installation and it must be ordered separately

Electrical Requirement	
Power Supply	208/230V, 1 Phase, 60 HZ
Operating Voltage Range	187~253 VAC
Recommended Fuse/Breaker Size	30A
MCA	26A

Connecting cable to indoor units must be 14/4 AWG unshielded stranded copper. Cable must be ran continuous, without splicing.

Operating Range	
Cooling	0~115°F (-18~46°C)
Heating	-4~75°F (-20~24°C)

Cooling Performance	
Rated Cooling Capacity	35,000 BTU
Cooling Capacity Range	8,500~37,500 BTU
Rated Power input	3,500 W
SEER	17.0
EER	10.0

Heating Performance	
Rated Heating Capacity	36,500 BTU
Heating Capacity Range	8,500~38,500 BTU
HSPF	10.3

Pipe Length	
Minimum Pipe Length	6 ft
Maximum Pipe Length	165 ft
Maximum Pipe Height Difference	100 ft
Connection	3/8" (Discharge) 5/8" (Suction) Flare



For more information visit us:
www.Haierductless.com
www.Haierductlesshelp.com



Haier FlexFit Pro Single Submittal

36000 BTU/HR 3x3 LARGE CASSETTE INVERTER DRIVEN HEAT PUMP SYSTEM 1U36LP2VHA / AL36LP2VHA

Indoor Unit	
Uncrated Dimension (HxWxD)	9 5/8 x 33 1/8 x 33 1/8 in (246 x 840 x 840 mm)
Crated (HxWxD)	12 1/4 x 39 x 39 in (310 x 990 x 990 mm)
Panel Uncrated Dimension (HxWxD)	2 x 37 3/8 x 37 3/8 in (50 x 950 x 950 mm)
Panel Crated (HxWxD)	4 3/8 x 39 3/8 x 39 3/8 in (110 x 1000 x 1000 mm)
Airflow CFM (Turbo/High/Med/Low/Quiet)	740/630/480/400
Indoor Sound Level dB (Turbo/High/Med/Low/Quiet)	45/42/38/34
Motor Rating (HP)	0.161
Heat Exchanger Fin Type	Blue Fin
Condensate Pump	Included - 47.2 in Lift
Weight (Ship/Net)	79.4/68.3 lbs

Outdoor Unit	
Compressor	DC inverter Driven Rotary
Uncrated Dimension (HxWxD)	38 x 37 3/8 x 14 5/8 in (965 x 950 x 370 mm)
Crated (HxWxD)	43 1/8 x 41 3/8 x 17 3/4 in (1095 x 1050 x 450 mm)
Outdoor Sound Rating dB	52
Heat Exchanger Fin Type	Blue Fin
Weight (Ship/Net)	207.2/180.7 lbs
Factory Refrigerant Charge	R-410A (88.2 oz)

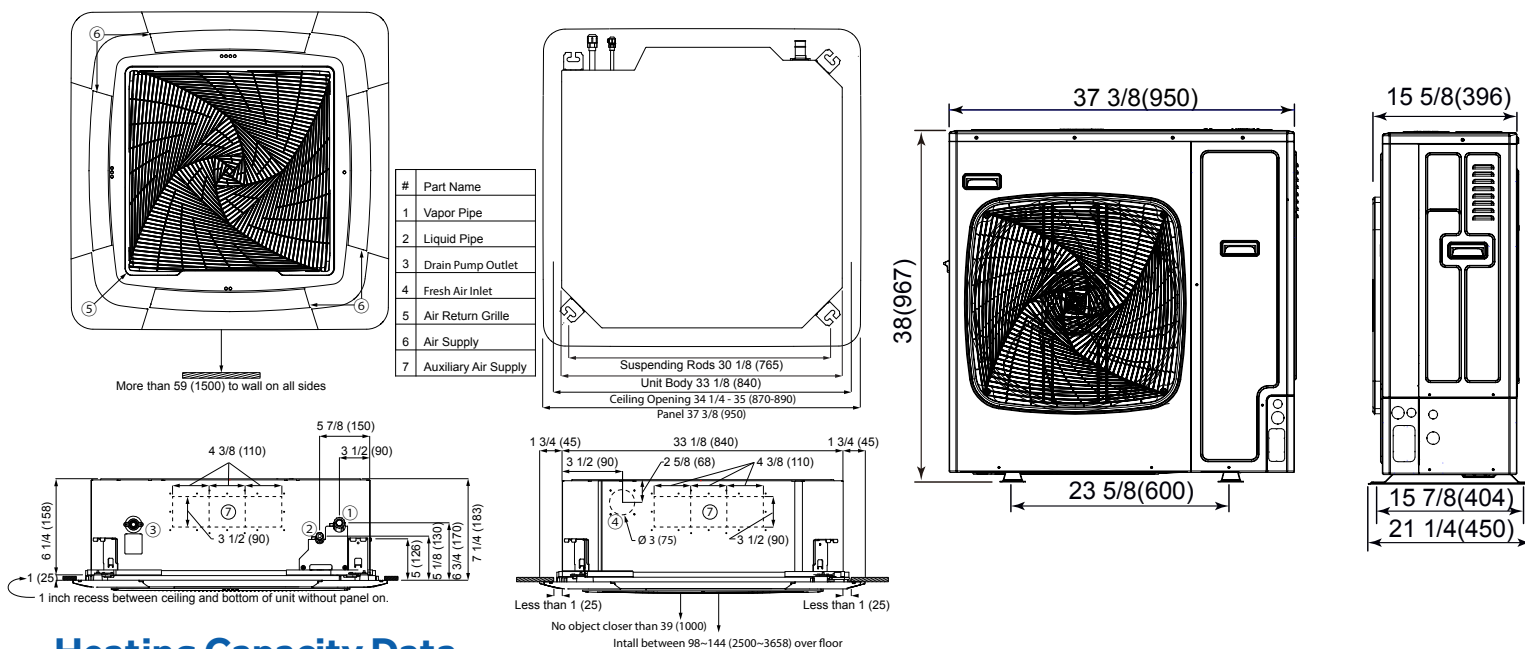

Heating Capacity Data

Outdoor Air Temp DB	Indoor Set Temperature					
	60°F (16°C)		70°F (21°C)		77°F (25°C)	
	Maximum Heating Capacity (Btu/h)	Power Usage (w)	Max Heating Capacity (Btu/h)	Power Usage (w)	Max Heating Capacity (Btu/h)	Power Usage (w)
-4°F (-20°C)	19,890	2,510	18,780	2,560	17,960	2,520
5°F (-15°C)	22,350	2,690	21,050	2,710	20,460	2,750
17°F (-8°C)	27,360	3,220	26,140	3,210	25,470	3,280
47°F (8°C)	37,980	3,430	37,070	3,490	36,210	3,500

Cooling Capacity Data

Outdoor Air Temp DB	Indoor Set Temperature					
	70°F (21°C)		75°F (24°C)		80°F (27°C)	
	Total Capacity (Btu/h)	Power Usage (w)	Total Capacity (Btu/h)	Power Usage (w)	Total Capacity (Btu/h)	Power Usage (w)
0°F (-18°C)	34,160	2,330	34,930	2,510	35,780	2,520
14°F (-10°C)	34,970	2,520	35,740	2,700	36,170	2,710
32°F (0°C)	35,710	2,690	36,480	2,880	36,540	2,890
50°F (10°C)	36,090	2,850	36,840	3,040	36,950	3,050
65°F (18°C)	35,670	3,010	36,450	3,180	36,600	3,190
75°F (24°C)	35,200	3,110	35,970	3,290	36,240	3,300
85°F (29°C)	35,410	3,190	36,180	3,370	35,830	3,380
95°F (35°C)	34,870	3,290	35,640	3,470	35,710	3,480
105°F (41°C)	34,710	3,680	35,480	3,860	35,550	3,900
115°F (46°C)	31,430	3,560	32,200	3,740	33,060	3,750

Capacity and power usage are measured under the assumption of indoor humidity of 46%

Haier FlexFit Pro Single Submittal

48000 BTU/HR HIGH STATIC DUCTED INDOOR INVERTER DRIVEN HEAT PUMP SYSTEM 1U48LP2VHA / AM48LP2VHA

Job Name: _____

Purchaser: _____

Submitted To: _____

Construction: _____

Reference: _____

Approval: _____

Date: _____

Submitted By: _____

Unit: _____

Drawing #: _____



Accessories

Remote Controller

Ships with YR-E17

Wired Controller

Compatible with wired controllers YR-E16B and QACT17A

Wind Baffle

Uses wind baffle QAWB38A (requires 2)

Electrical Requirement	
Power Supply	208/230V, 1 Phase, 60 HZ
Operating Voltage Range	187~253 VAC
Recommended Fuse/Breaker Size	40A
MCA	35A

Connecting cable to indoor units must be 14/4 AWG unshielded stranded copper. Cable must be ran continuous, without splicing.

Operating Range	
Cooling	0~115°F (-18~46°C)
Heating	-4~75°F (-20~24°C)

Cooling Performance	
Rated Cooling Capacity	47,000 BTU
Cooling Capacity Range	11,900~54,500 BTU
Rated Power input	4,476 W
SEER	17.0
EER	10.5

Heating Performance	
Rated Heating Capacity	52,000 BTU
Heating Capacity Range	13,600~64,800 BTU
HSPF	10.0

Pipe Length	
Minimum Pipe Length	6 ft
Maximum Pipe Length	230 ft
Maximum Pipe Height Difference	100 ft
Connection	3/8" (Discharge) 5/8" (Suction) Flare



For more information visit us:
www.Haierductless.com
www.Haierductlesshelp.com



Haier FlexFit Pro Single Submittal

48000 BTU/HR HIGH STATIC DUCTED INDOOR INVERTER DRIVEN HEAT PUMP SYSTEM

1U48LP2VHA / AM48LP2VHA

Indoor Unit	
Uncrated Dimension (HxWxD)	9 7/8 x 59 x 28 3/8 in (250 x 1500 x 720 mm)
Crated (HxWxD)	13 3/8 x 63 3/4 x 33 7/8 in (340 x 1620 x 860 mm)
Maximum ESP (IWC)	0.60
Airflow CFM (Turbo/High/Med/Low/Quiet)	1350/1150/930/765
Indoor Sound Level dB (Turbo/High/Med/Low/Quiet)	41/36/33/31
Motor Rating (HP)	0.617
Heat Exchanger Fin Type	Blue Fin
Condensate Pump	Included - 27.5 in Lift
Weight (Ship/Net)	132.3/114.6 lbs

Outdoor Unit	
Compressor	DC inverter Driven Rotary
Uncrated Dimension (HxWxD)	53 1/8 x 37 3/8 x 14 5/8 in (1350 x 950 x 370 mm)
Crated (HxWxD)	59 x 42 7/8 x 18 7/8 in (1500 x 1090 x 480 mm)
Outdoor Sound Rating dB	53
Heat Exchanger Fin Type	Blue Fin
Weight (Ship/Net)	260.1/231.5 lbs
Factory Refrigerant Charge	R-410A (131 oz)

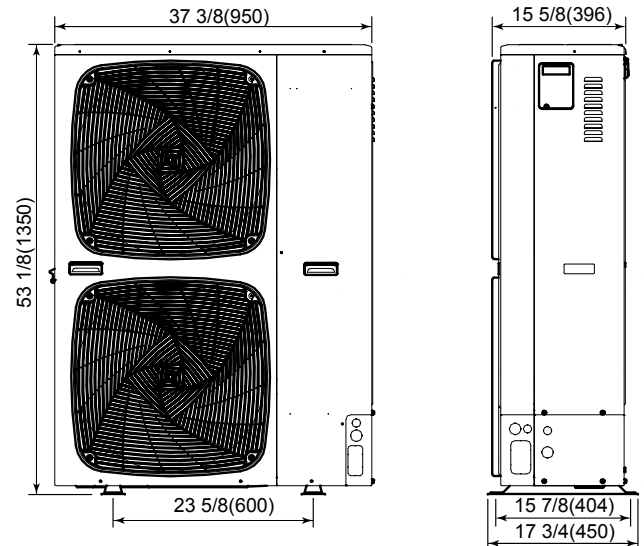
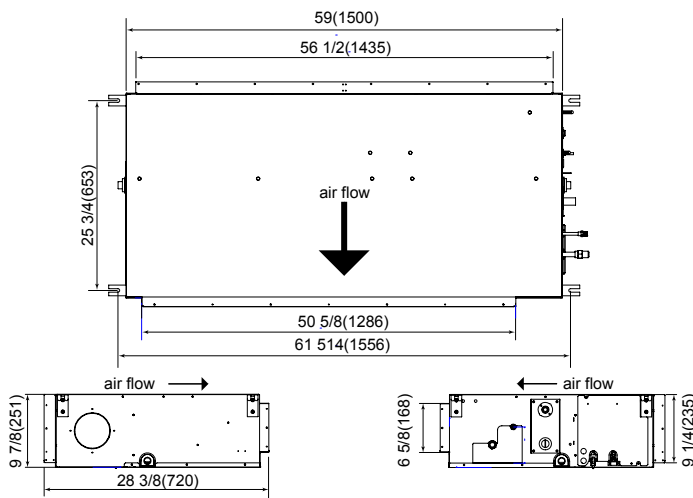

Heating Capacity Data

Outdoor Air Temp DB	Indoor Set Temperature					
	60°F (16°C)		70°F (21°C)		77°F (25°C)	
	Maximum Heating Capacity (Btu/h)	Power Usage (w)	Max Heating Capacity (Btu/h)	Power Usage (w)	Max Heating Capacity (Btu/h)	Power Usage (w)
-4°F (-20°C)	28,710	3,490	27,680	3,510	26,450	3,520
5°F (-15°C)	32,400	3,950	31,200	3,920	29,980	3,950
17°F (-8°C)	35,620	4,030	34,210	4,170	33,560	4,150
47°F (8°C)	52,120	4,630	51,190	4,790	50,870	4,830

Capacity and power usage are measured under the assumption of indoor humidity of 46%

Cooling Capacity Data

Outdoor Air Temp DB	Indoor Set Temperature					
	70°F (21°C)		75°F (24°C)		80°F (27°C)	
	Total Capacity (Btu/h)	Power Usage (w)	Total Capacity (Btu/h)	Power Usage (w)	Total Capacity (Btu/h)	Power Usage (w)
0°F (-18°C)	44,540	3,360	45,260	3,380	45,870	3,410
14°F (-10°C)	45,790	3,470	46,510	3,490	47,120	3,520
32°F (0°C)	47,110	3,590	47,890	3,610	48,420	3,650
50°F (10°C)	48,410	3,840	49,290	3,790	49,920	3,910
65°F (18°C)	47,650	4,260	48,370	4,280	48,980	4,310
75°F (24°C)	47,190	4,470	47,780	4,490	48,520	4,520
85°F (29°C)	46,980	4,560	47,700	4,580	48,310	4,610
95°F (35°C)	46,650	4,730	47,370	4,750	47,980	4,780
105°F (41°C)	43,990	5,260	44,710	5,280	45,320	5,310
115°F (46°C)	38,890	4,160	39,620	4,180	40,210	4,810

Capacity and power usage are measured under the assumption of indoor humidity of 46%

Haier FlexFit Pro Single Submittal

48000 BTU/HR 3x3 LARGE CASSETTE INVERTER DRIVEN HEAT PUMP SYSTEM 1U48LP2VHA / AL48LP2VHA

Job Name: _____

Purchaser: _____

Submitted To: _____

Construction: _____

Reference: _____

Approval: _____

Date: _____

Submitted By: _____

Unit: _____

Drawing #: _____



Accessories

Remote controller

Ships with YR-HBS01

Wired Thermostat

Compatible with wired controllers YR-E17, YR-E16B, and QACT17A.

Wind Baffle

Uses wind baffle QAWB38A (requires 2)

Panel

PB-950KB is required to complete the installation and it must be ordered separately

Electrical Requirement

Power Supply	208/230V, 1 Phase, 60 HZ
Operating Voltage Range	187~253 VAC
Recommended Fuse/Breaker Size	40A
MCA	35A

Connecting cable to indoor units must be 14/4 AWG unshielded stranded copper. Cable must be ran continuous, without splicing.

Operating Range

Cooling	0~115°F (-18~46°C)
Heating	-4~75°F (-20~24°C)

Cooling Performance

Rated Cooling Capacity	45,000 BTU
Cooling Capacity Range	11,900~52,800 BTU
Rated Power input	4286 W
SEER	17.0
EER	10.5

Heating Performance

Rated Heating Capacity	49,000 BTU
Heating Capacity Range	13,600~61,000 BTU
HSPF	10.5

Pipe Length

Minimum Pipe Length	6 ft
Maximum Pipe Length	230 ft
Maximum Pipe Height Difference	100 ft
Connection	3/8" (Discharge) 5/8" (Suction) Flare



For more information visit us:
www.Haierductless.com
www.Haierductlesshelp.com



Haier FlexFit Pro Single Submittal

48000 BTU/HR 3x3 LARGE CASSETTE INVERTER DRIVEN HEAT PUMP SYSTEM

1U48LP2VHA / AL48LP2VHA

Indoor Unit	
Uncrated Dimension (HxWxD)	11 3/8 x 33 1/8 x 33 1/8 in (288 x 840 x 840 mm)
Crated (HxWxD)	15 x 39 x 39 in (380 x 990 x 990 mm)
Panel Uncrated Dimension (HxWxD)	2 x 37 3/8 x 37 3/8 in (50 x 950 x 950 mm)
Panel Crated (HxWxD)	4 3/8 x 39 3/8 x 39 3/8 in (110 x 1000 x 1000 mm)
Airflow CFM (Turbo/High/Med/Low/Quiet)	740/630/480/400
Indoor Sound Level dB (Turbo/High/Med/Low/Quiet)	41/36/33/31
Motor Rating (HP)	0.161
Heat Exchanger Fin Type	Blue Fin
Condensate Pump	Included - 47.2 in Lift
Weight (Ship/Net)	83.8/70.5 lbs

Outdoor Unit	
Compressor	DC inverter Driven Rotary
Uncrated Dimension (HxWxD)	53 1/8 x 37 3/8 x 14 5/8 in (1350 x 950 x 370 mm)
Crated (HxWxD)	59 x 42 7/8 x 18 7/8 in (1500 x 1090 x 480 mm)
Outdoor Sound Rating dB	53
Heat Exchanger Fin Type	Blue Fin
Weight (Ship/Net)	260.1/231.5 lbs
Factory Refrigerant Charge	R-410A (131 oz)

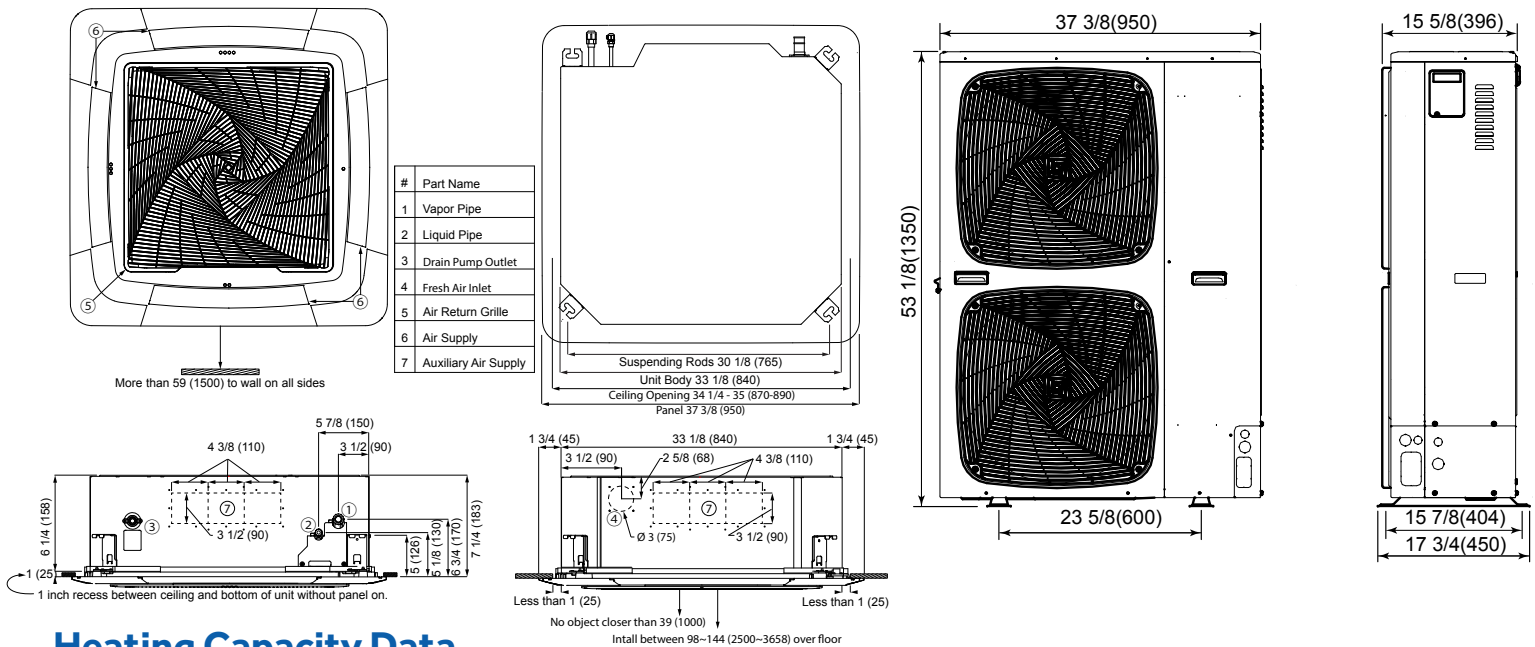

Heating Capacity Data

Outdoor Air Temp DB	Indoor Set Temperature					
	60°F (16°C)		70°F (21°C)		77°F (25°C)	
	Maximum Heating Capacity (Btu/h)	Power Usage (w)	Max Heating Capacity (Btu/h)	Power Usage (w)	Max Heating Capacity (Btu/h)	Power Usage (w)
-4°F (-20°C)	29,780	3,510	28,890	3,600	27,120	3,590
5°F (-15°C)	34,290	4,090	32,380	3,960	31,590	4,070
17°F (-8°C)	38,250	4,100	37,640	4,140	35,830	4,190
47°F (8°C)	52,320	4,680	51,280	4,810	51,120	4,870

Cooling Capacity Data

Outdoor Air Temp DB	Indoor Set Temperature					
	70°F (21°C)		75°F (24°C)		80°F (27°C)	
	Total Capacity (Btu/h)	Power Usage (w)	Total Capacity (Btu/h)	Power Usage (w)	Total Capacity (Btu/h)	Power Usage (w)
0°F (-18°C)	44,330	3,350	45,070	3,360	45,670	3,390
14°F (-10°C)	45,580	3,460	46,320	3,470	46,920	3,500
32°F (0°C)	46,940	3,580	47,640	3,600	48,270	3,630
50°F (10°C)	48,360	3,810	49,100	3,970	49,520	3,910
65°F (18°C)	47,440	4,250	48,180	4,260	48,780	4,290
75°F (24°C)	46,980	4,460	47,590	4,470	48,320	4,500
85°F (29°C)	46,770	4,550	47,510	4,560	48,110	4,590
95°F (35°C)	46,440	4,720	47,180	4,730	47,780	4,760
105°F (41°C)	43,780	5,250	44,520	5,260	45,120	5,290
115°F (46°C)	38,680	4,150	39,430	4,160	40,010	4,780

Capacity and power usage are measured under the assumption of indoor humidity of 46%