

INTEGRATED REFRIGERATION

INSTALLATION INSTRUCTIONS





CONTENTS

Installation Recommendations	3
Installation Specifications	4
Installation Instructions	7
Installation Checklist	18
Service Information	19

Features and specifications indicated herein and on the website are subject to change at any time without notice. Check our website, subzero.com, for the most up-to-date specifications.

As you follow these instructions, you will notice **WARNING** and **CAUTION** symbols. This blocked information is important for the safe and efficient installation of Sub-Zero equipment. There are two types of potential hazards that may occur during installation.

⚠ CAUTION

signals a situation where minor injury or product damage may occur if you do not follow instructions.

⚠ WARNING

states a hazard that may cause serious injury or death if precautions are not followed.

Another footnote we would like to identify is **IMPORTANT NOTE**: This highlights information that is especially relevant to a problem-free installation.



INSTALLATION RECOMMENDATIONS

The importance of the installation of the Sub-Zero Integrated unit cannot be overemphasized. Installation should be done by a qualified installer.

Before you begin the installation process, it is recommended that you read this entire Installation Instructions book. There are key details that you should take special care to observe during the installation. By reading these instructions carefully, you will make the installation process easier, problem-free and, most importantly, safe.

Any questions or problems about the installation should be directed to your Sub-Zero dealer or the Sub-Zero Customer Service Department at 800-222-7820. You can also visit our website at subzero.com.

SITE PREPARATION

Make sure that the finished rough opening where the Integrated unit is to be installed is properly prepared. Refer to the Overall Dimensions and Installation illustrations for your specific model on the following pages. Make sure that the rough opening dimensions, door and drawer clearances, electrical service and plumbing are correct for the model you are about to install.

Be sure that the plumber, electrician and cabinet installer have this information before finishing work is completed.

IMPORTANT NOTE: The inside edges of the rough opening, as well as the sides and a portion of the backside of the decorative panels will need to be finished, as they will be exposed when the doors are open.

TOOLS AND MATERIALS REQUIRED

The following is a list of tools and materials that should be available for proper installation.

- Phillips screwdriver set
- Slotted screwdriver set
- 4' (1.2 m) of 1/4" copper tubing and saddle valve for the water line—part #4200880 (do not use self-piercing valves)
- Copper tubing cutter
- Level—2' (.6 m) and 4' (1.2 m) recommended
- Appliance dolly able to support 500 lbs (227 kg) and adequate help to handle the weight of the unit
- Various sized pliers
- Wrench set
- Allen wrench set
- 5/16" hex bolt nut driver
- Crescent wrenches
- Drill and assorted drill bits
- Masonite, plywood, 1/8" pressed fiberboard, cardboard or other suitable material to protect finished flooring
- Appropriate materials to cover and protect the home and its furnishings during installation



INTEGRATED INSTALLATION SPECIFICATIONS

OVERALL DIMENSIONS

Models 700TR, 700TF(I) and 700TC(I)

TALL UNITS
27" (686) Wide Units

Model 700TR

All Refrigerator

Model 700TF

All Freezer

Model 700TFI

All Freezer
with Ice Maker

Model 700TC

Refrigerator / Freezer

Model 700TCI

Refrigerator / Freezer
with Ice Maker

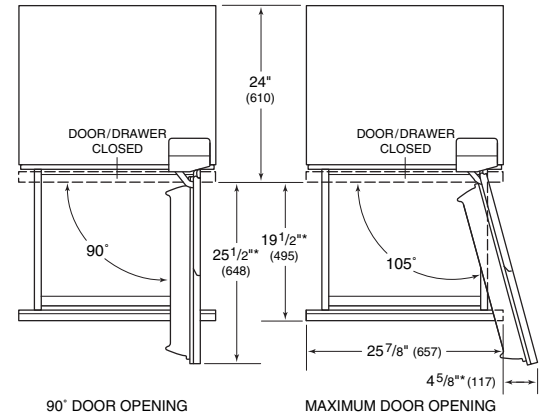
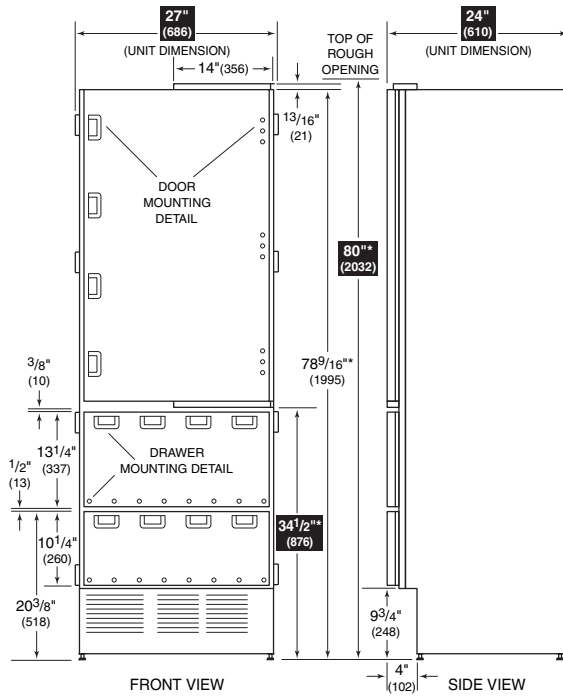

*DOOR/DRAWER PANEL THICKNESS NOT INCLUDED - DIMENSION WILL VARY WITH INSTALLATION

SPECIFICATIONS

Overall Dimensions

Width 27" (686)

Height 80" (2032)

Depth 24" (610)

Finished Opening

Width 27" (686)

Height 80" (2032)

Depth 25" (635)*

*The depth of the unit is 24" (610) from the front of the unit to its back. Your design may necessitate moving the unit back or cabinets forward to achieve a flush fit. This will require a minimum rough opening depth of 25" (635).

INSTALLATION

Models 700TR, 700TF(I) and 700TC(I)

Models without an ice maker will not require the water line connection.

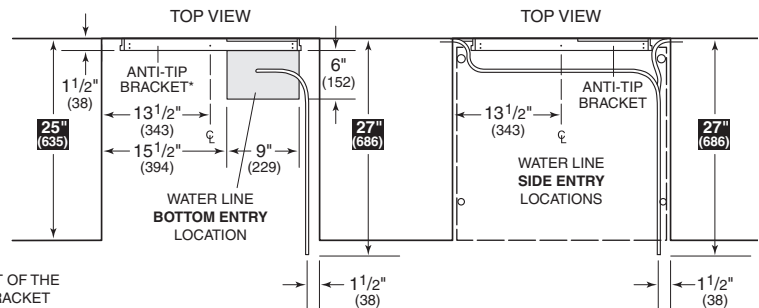

*PLACEMENT OF THE ANTI-TIP BRACKET SHOULD BE 24" (610) FROM THE FRONT OF THE UNIT WITHOUT PANELS TO THE BACK OF THE ANTI-TIP BRACKET.

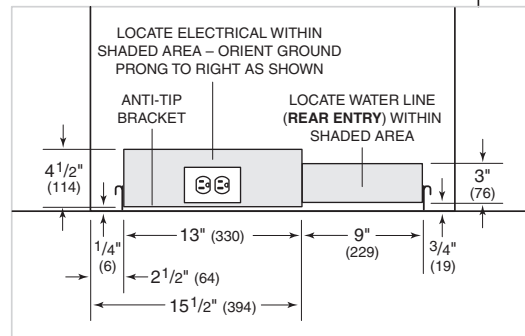

NOTE: ANTI-TIP BRACKET MUST BE INSTALLED TO PREVENT UNIT FROM TIPPING FORWARD

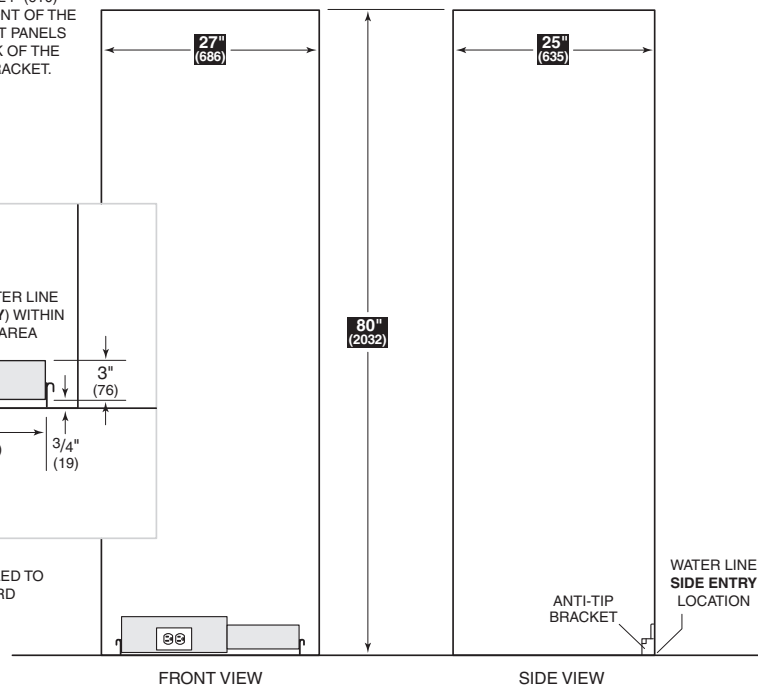



OVERALL DIMENSIONS
Models 736TR and 736TC(I)

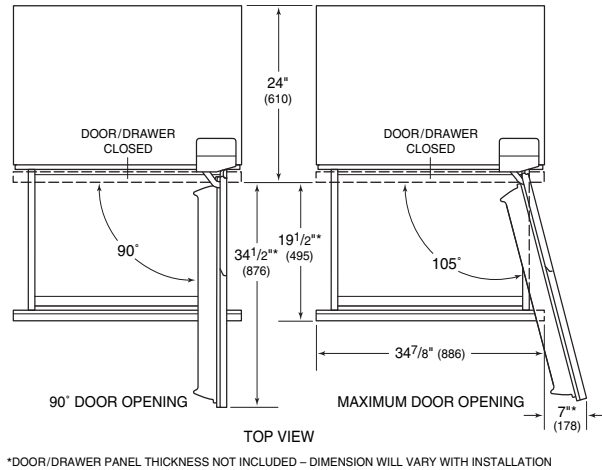
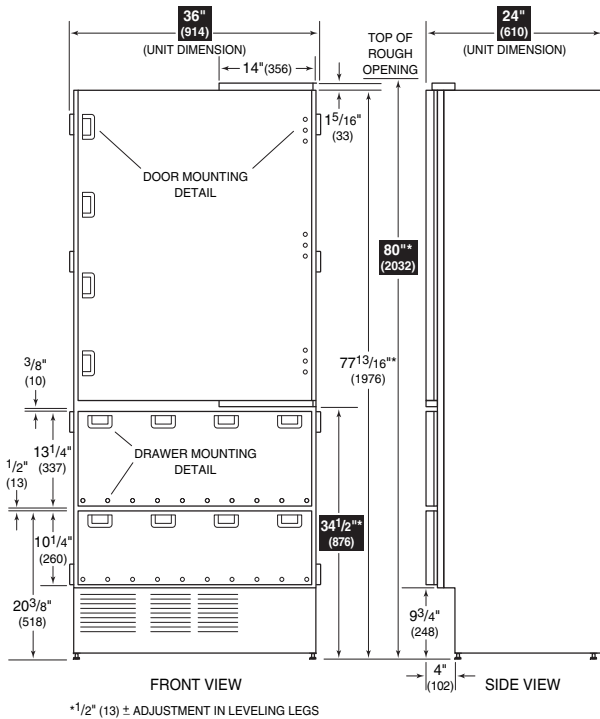

TALL UNITS
36" (914) Wide Units

- Model 736TR**
All Refrigerator
- Model 736TC**
Refrigerator / Freezer
- Model 736TC(I)**
Refrigerator / Freezer with Ice Maker

SPECIFICATIONS

Overall Dimensions
Width 36" (914)
Height 80" (2032)
Depth 24" (610)

Finished Opening
Width 36" (914)
Height 80" (2032)
Depth 25" (635)*

**The depth of the unit is 24" (610) from the front of the unit to its back. Your design may necessitate moving the unit back or cabinets forward to achieve a flush fit. This will require a minimum rough opening depth of 25" (635).*

INSTALLATION
Models 736TR and 736TC(I)

Models without an ice maker will not require the water line connection.

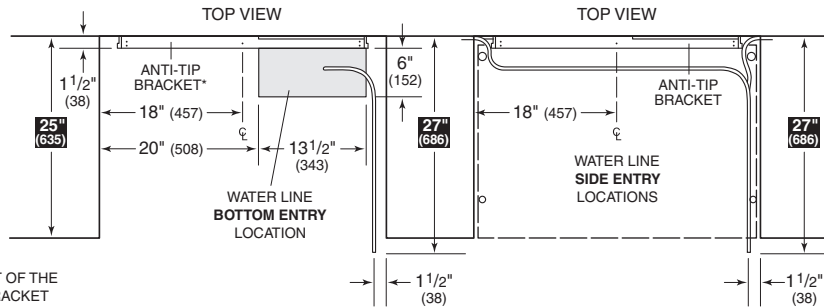

*PLACEMENT OF THE ANTI-TIP BRACKET SHOULD BE 24" (610) FROM THE FRONT OF THE UNIT WITHOUT PANELS TO THE BACK OF THE ANTI-TIP BRACKET.

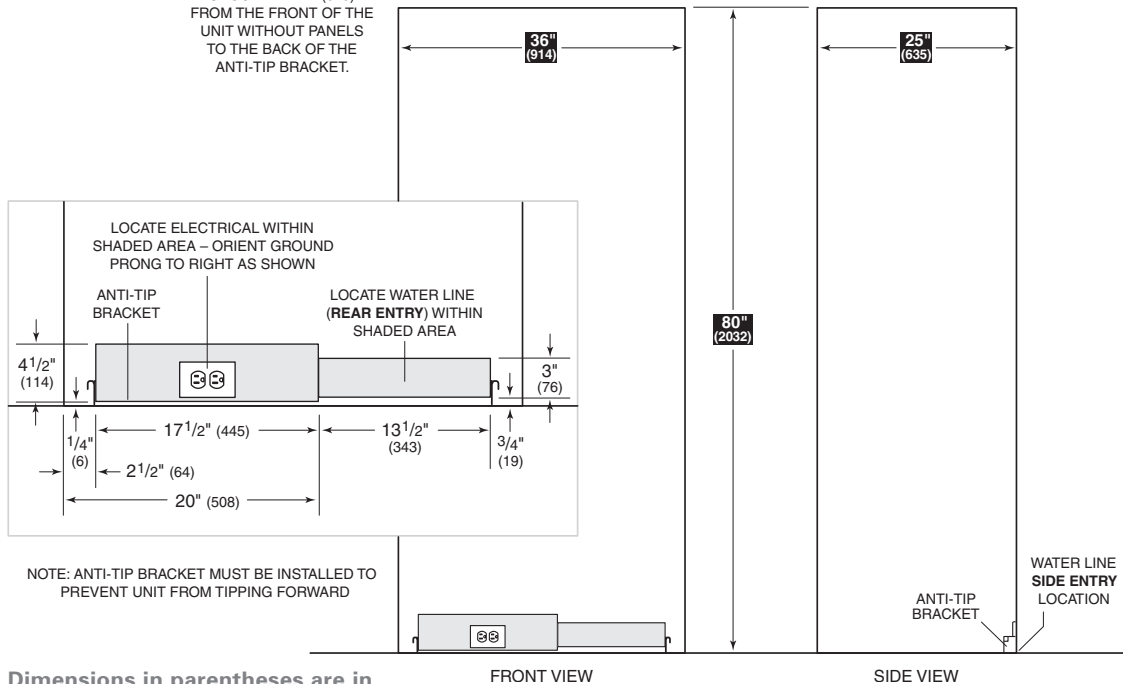

Dimensions in parentheses are in millimeters unless otherwise specified.



INTEGRATED INSTALLATION SPECIFICATIONS

OVERALL DIMENSIONS Models 700BR, 700BF(I) and 700BC(I)

BASE UNITS

Model 700BR
All Refrigerator

Model 700BF
All Freezer

Model 700BF1
All Freezer
with Ice Maker

Model 700BC
Refrigerator / Freezer

Model 700BC1
Refrigerator / Freezer
with Ice Maker

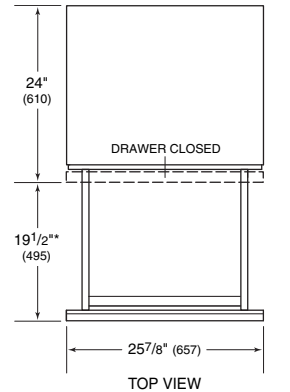
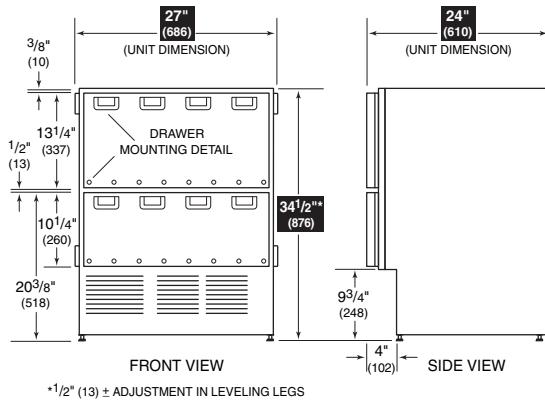

*DRAWER PANEL THICKNESS NOT INCLUDED

SPECIFICATIONS

Overall Dimensions

Width **27" (686)**
Height **34 1/2" (876)**
Depth **24" (610)**

Finished Opening

Width **27" (686)**
Height **34 1/2" (876)**
Depth **25" (635)***

**The depth of the unit is 24" (610) from the front of the unit to its back. Your design may necessitate moving the unit back or cabinets forward to achieve a flush fit. This will require a minimum rough opening depth of 25" (635).*

INSTALLATION

Models 700BR, 700BF(I) and 700BC(I)

Models without an ice maker will not require the water line connection.

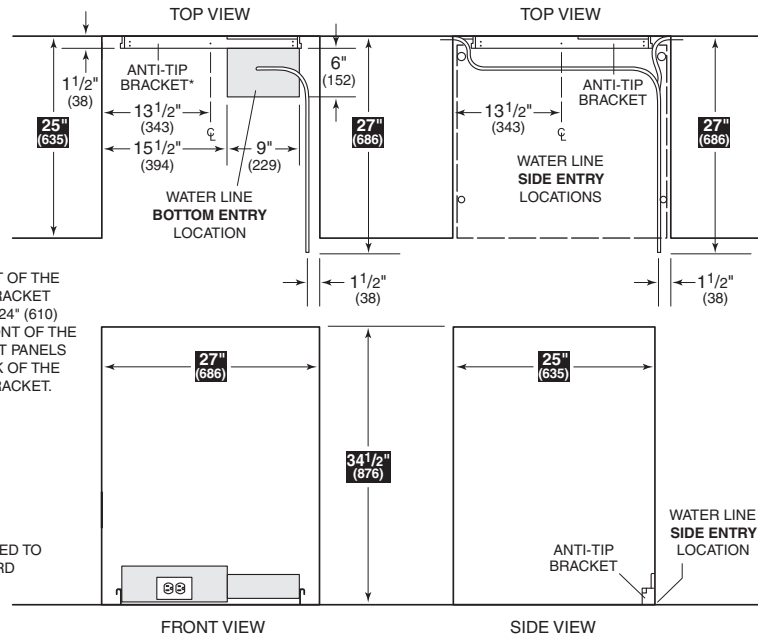

*PLACEMENT OF THE ANTI-TIP BRACKET SHOULD BE 24" (610) FROM THE FRONT OF THE UNIT WITHOUT PANELS TO THE BACK OF THE ANTI-TIP BRACKET.

NOTE: ANTI-TIP BRACKET MUST BE INSTALLED TO PREVENT UNIT FROM TIPPING FORWARD

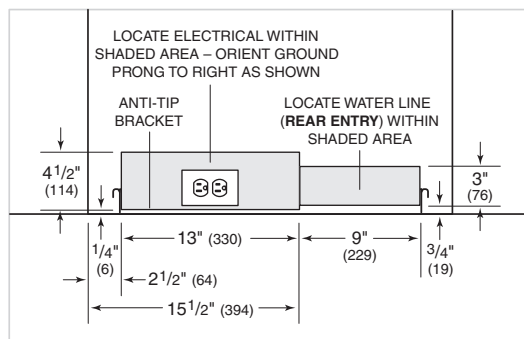



ELECTRICAL REQUIREMENTS

A 115 V AC, 60 Hz, 15 amp circuit breaker and electrical supply are required. A separate circuit, serving only this appliance, is required for each Integrated unit.

All Integrated models are equipped with a power supply cord with a 3-prong grounding plug, which must be plugged into a mating 3-prong grounding-type wall receptacle. Follow the National Electrical Code and local codes and ordinances when installing the receptacle. For location of the electrical supply, refer to the Installation illustration for your unit on pages 4–6.

IMPORTANT NOTE: The electrical outlet must be placed so that the grounding prong is to the right of the thinner blades. The outlet must be flush with the back wall.

IMPORTANT NOTE: A ground fault circuit interrupter (GFCI) is not recommended and may cause interruption of operation.

⚠ WARNING

Do not use an extension cord or two-prong adapter. Electrical ground is required on this appliance. Do not remove the power supply cord ground prong.

⚠ CAUTION

The outlet must be checked by a qualified electrician to be sure that it is wired with the correct polarity. Verify that the outlet provides 115 V AC and is properly grounded.

⚠ WARNING

Always shut power off at the circuit breaker before performing any installation, service or maintenance.

PLUMBING REQUIREMENTS

For Integrated models with an automatic ice maker, rough in the water supply line. Connect the 1/4" water line from the ice maker water valve to the house water supply. Use an easily accessible shut-off valve between the water supply and the unit. This shut-off valve should not be installed behind the unit. Do not use self-piercing valves. A saddle valve kit (part #4200880) is available from your Sub-Zero dealer.

The Installation illustrations on pages 4–6 show the precise placement of the water line. When routing through the side walls, you must place the water line within 1/2" (13) of the floor and as close as possible to the back wall.

The line must be routed around the anti-tip bracket so it clears the bracket and the leveling feet of the unit. Refer to the top view in the Installation illustration for your unit on pages 4–6. Regardless of the routing, allow for 27" (686) of excess water line to remain outside the wall or floor for easy connection to the unit.

IMPORTANT NOTE: Do not route the water supply line in front of the compressor tray. The tray must be slid forward for service.

A line filter is required when water conditions have a high sediment content. The ice maker operates on water pressure of 20 psi (1.4 bar) to 100 psi (6.9 bar).

A reverse osmosis system can be used, provided there is a consistent water pressure of 20 psi (1.4 bar) to 100 psi (6.9 bar) supplied to the water valve at all times.

IMPORTANT NOTE: In some cases a reverse osmosis water filter system may not be able to maintain the minimum water pressure consistently.

OPTIONAL COMPONENTS

Optional installation components are available through your Sub-Zero dealer. For questions relative to the installation, call Sub-Zero at 800-222-7820.



PANEL CONSIDERATIONS

DOOR AND DRAWER PANELS

To install door and drawer panels, refer to the instructions under Panel Installation on page 14. You should check panel dimensions and placement before proceeding with installation of the Integrated unit. If you have questions, contact your Sub-Zero dealer or cabinet supplier. Instructions regarding sizing of the panels are provided in the Sub-Zero Design Guide.

IMPORTANT NOTE: The backside of the decorative panels will need to be finished, as they will be exposed when the doors are open.

SIDE PANELS

Side panels for integrated models are not attached to the unit. You must securely fasten the panels to adjacent cabinets and floor.

Panels should be fastened to the floor and walls using 'L' brackets (hardware not provided). To help you move the unit into place, rout out an area in the floor so the 'L' bracket will sit flush with the floor level. Brackets and screws are provided for mounting the unit to adjoining cabinets and side panels. On the tall units, there are four side mounting clips on each side and on the base units, there are two per side. Side panels must be a minimum of 3/4" (19) thick.

IMPORTANT NOTE: For installations where you are not attaching to a side wall or you are installing two Integrated units together, you must remove the clips before moving the unit into place. After removing the clips, replace the screws in the holes and discard the clips.

Optional components are necessary for anchoring two Integrated units together. Refer to Dual Installations on page 17. Optional installation components are available through your Sub-Zero dealer. You can also visit our website at subzero.com.

UNPACKING AND MOVING

Uncrate the unit, remove its wood base and discard the shipping bolts that hold the wood base to the bottom of the unit. Remove all packing materials and tape.

IMPORTANT NOTE: Do not discard the kickplate/grille, anti-tip bracket and hardware. These items will be needed for the installation.

Retract the front leveling legs to allow you to move the unit more easily during installation. You will extend the leveling legs when the unit is in its final position to reduce the possibility of the unit tipping forward.

Use an appliance dolly to move the Integrated unit. Position the dolly at the side of the unit to prevent damage to finished surfaces. Secure the door and/or drawers so they do not open while moving the unit.

CAUTION
Before moving the Integrated unit into position, protect any finished flooring with appropriate materials.

PANEL DESIGN

Additional panel design information can be found in the Sub-Zero Design Guide. Check our website at subzero.com.

Dimensions in parentheses are in millimeters unless otherwise specified.



ANTI-TIP BRACKET INSTALLATION

⚠ WARNING
To prevent the unit from tipping forward and provide a stable installation, the unit must be secured in place with the anti-tip blocking bracket.

An anti-tip bracket and hardware is provided with the Integrated unit. The anti-tip bracket must be installed on a solid base.

If you are installing the unit in a space deeper than 24", be sure to locate the anti-tip bracket so that it engages the unit properly. It is important that the anti-tip bracket is placed 24" from the front of the unit without panels, to the back of the anti-tip bracket. Refer to illustrations 1 and 2 below and note that for 27" (686) wide units dimension A is 13 1/2" (343), and 18" (457) for 36" (914) wide units.

WOOD FLOOR APPLICATIONS

Use the six #12 x 2 1/2" wood screws and the six 1/4" flat washers provided. Drill pilot holes 3/16" (5) diameter maximum, and be sure that the screws penetrate through the flooring material and into the wall plate a minimum of 3/4" (19). Be sure that the screws hold tight. Refer to illustration 1 below.

CONCRETE FLOOR APPLICATIONS

Use the two 3/8" x 3 3/4" concrete wedge anchors, two #12 x 2 1/2" wood screws and two 1/4" flat washers provided. Be sure that the anchors and screws hold tight. Refer to illustration 2 below.

IMPORTANT NOTE: In some installations the subflooring or finished floor may require angling the wood screws used to fasten the anti-tip bracket to the back wall. Refer to illustrations 1 and 2.

⚠ WARNING
Make sure that there are no electrical wires or plumbing in the area which the screws could penetrate.

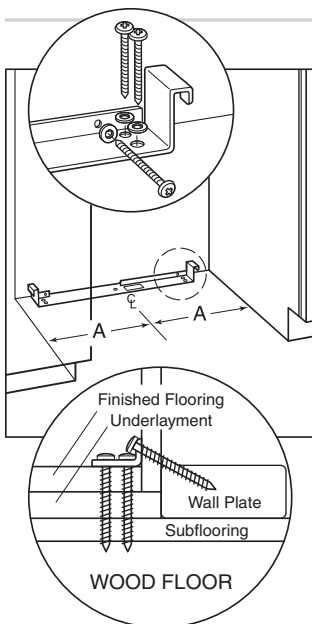

Illus. 1

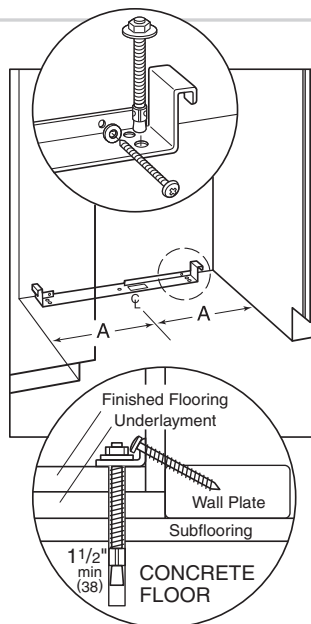

Illus. 2

SPECIFICATIONS

Dimension A

27" (686) Wide Units	13 1/2" (343)
36" (914) Wide Units	18" (457)



ANTI-TIP BLOCKING BRACKET

INSTALL CONCRETE WEDGE ANCHORS

- 1) Drill a 3/8" (10) diameter hole any depth exceeding the minimum embedment. Clean the hole or continue drilling additional depth to accommodate drill fines. Use a carbide drill bit manufactured within ANSI B94.12-77.
- 2) Assemble the washer and nut flush with the end of anchor to protect threads. Drive the anchor through the material to be fastened until the washer is flush with the surface material.
- 3) Expand the anchor by tightening the nut 3–5 turns past hand-tight position or to 25 foot-pounds of torque.

CAUTION

Always wear safety glasses and use other necessary protective devices or apparel when installing or working with anchors.

Anchors are not recommended for use in lightweight masonry material such as block or brick, or for use in new concrete which has not had sufficient time to cure. The use of core drills is not recommended to drill holes for the anchors.

POSITION THE UNIT

CAUTION

Before moving the Integrated unit into position, secure the door closed and remove the drawers.

IMPORTANT NOTE: On base units, the top drawer has a control cable that needs to be disconnected before removing this drawer. Refer to illustration 3 below for placement and how to disconnect this fitting.

The drawers should be placed aside until you are ready for installation of the panels. Remove the decorative top and side molding pieces and the kickplate/grille.

IMPORTANT NOTE: If two Integrated units are installed closer than 2" (51) to one another, it is necessary to use the Sub-Zero dual installation heater kit. Refer to Dual Installations on page 17 for additional information. The heater plate from this kit must be attached to the left side exterior of the right hand unit before the units are slid into position.

OPTIONAL COMPONENTS

Optional installation components are available through your Sub-Zero dealer. You can also visit our website at subzero.com. For questions relative to the installation, call Sub-Zero at 800-222-7820.

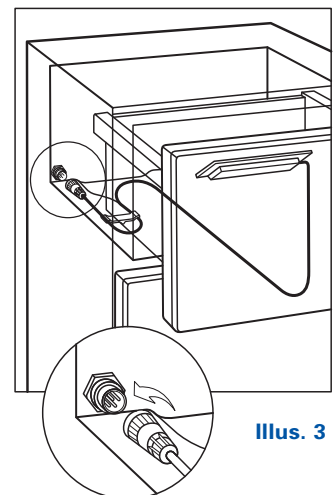

Illus. 3



⚠ WARNING
Shut off the power to the electrical outlet.

Before moving the Integrated unit into position, tape down the water supply line for the ice maker so it will stay in place as you move the unit. Refer to the Installation illustration for your unit on pages 4–6 for placement of the water line.

IMPORTANT NOTE: If for any reason the Integrated unit has been laid on its back or side, you must allow the unit to stand upright for a minimum of 24 hours before connecting power.

Plug the power supply cord into the 15 amp grounded electrical outlet. With power applied to the appliance, check for lighting and cooling before going any further. Press the **UNIT ON/OFF** key pad on the control panel. Refer to illustration 4 below for the location of the **UNIT ON/OFF** key pad for base units and illustration 5 for tall units. Once you are satisfied that the unit is operating properly, shut off power to the electrical outlet at the circuit breaker and proceed.

Pre-level the unit before moving into position. This is to allow the unit to engage the anti-tip bracket properly.

Slide the unit into position, making sure the anti-tip bracket is engaged properly. Screw the front leveling legs out approximately $\frac{3}{16}$ " (5) to make any future adjustments easier.

IMPORTANT NOTE: When the Integrated unit is installed, the anti-tip bracket will be positioned just below the engaging bracket on the unit. It is not necessary to raise the unit up so that it locks into the anti-tip bracket, but the unit must be in alignment with the anti-tip bracket.

IMPORTANT NOTE: The floor under the Integrated unit must be at the same level as the surrounding finished floor to allow the compressor tray to be slid forward for service.

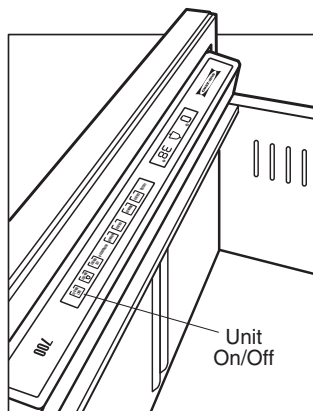

Illus. 4

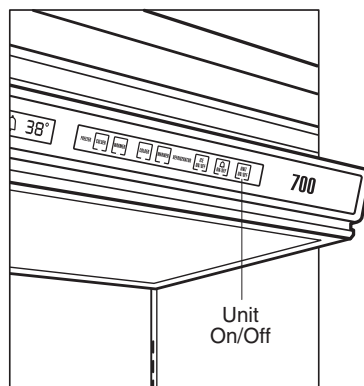

Illus. 5

Dimensions in parentheses are in millimeters unless otherwise specified.



LEVEL THE UNIT

Level the Integrated unit by turning the front leveling legs clockwise to raise the unit, or counterclockwise to lower it. To assist you in adjusting the front leveling legs up or down, use a standard screwdriver blade and place it in the front leveling leg as shown in illustration 6 below.

The rear leveling legs are adjusted from the front of the base by turning the Phillips head screw. Refer to illustration 7.

IMPORTANT NOTE: The rear leveling legs will only move 1/16" (2) for every 18 revolutions on the Phillips head screw. Do not over torque. Use the lowest torque setting on any power screwdriver. Do not turn the rear leveling legs by hand. Damage will occur if you turn these legs.

Once the unit is leveled, secure the unit in place by using the side mounting clips and #8 x 1/2" screws provided.

⚠ WARNING
To reduce the possibility of the unit tipping forward, the front leveling legs must be in contact with the floor.

MOLDING INSTALLATION

The decorative white molding strips for the side and top of the unit can be snapped into place. The top molding strip used on Integrated tall units, must be installed before the side molding can be attached. The top molding strip is held in place by double-sided velcro fasteners. Refer to illustration 8 below for positioning of the top molding.

Illustration 9 shows side molding installation for tall units. Installation of the side molding for base units is the same. For installations where units are side by side, refer to Dual Installations on page 17.

NOTE: The molding strips may be painted to match the surrounding cabinetry, if you choose. Follow these easy steps:

- Rough up the surface to be painted with fine grit sandpaper.
- Wipe with alcohol to ensure that the surface is clean and dry.
- Use an appliance or industrial grade, oil base, high gloss enamel paint.

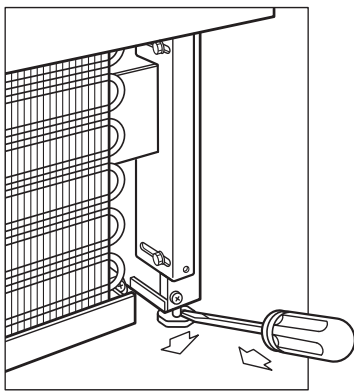

Illus. 6

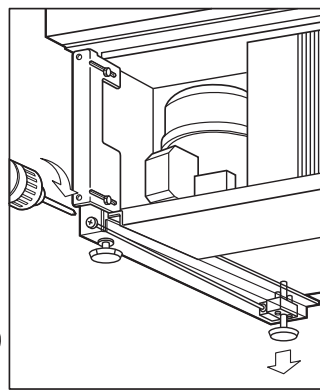

Illus. 7

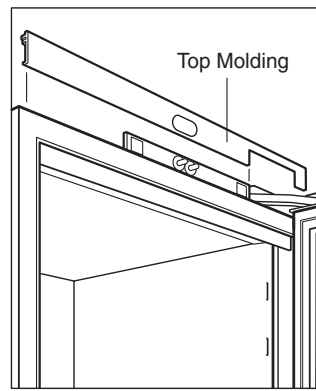

Illus. 8

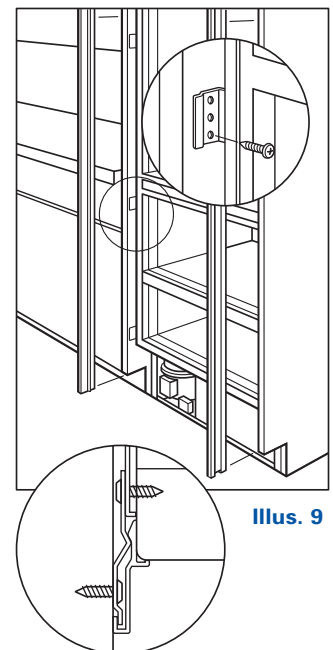

Illus. 9



WATER LINE CONNECTION

QUICK CONNECT WATER VALVE

For units with an ice maker, the quick connect water valve and PEX tubing are located on the right-hand side of the unit towards the bottom. Follow these instructions to connect the ice maker water line.

Attach the union fitting to the copper house water supply line. Pull the coiled gray PEX tubing with a red cap and captured metal nut toward the house water supply line. Remove and discard the red cap, then attach the tubing to the union with captured nut. Tighten all connections. Recoil the excess tubing under the unit. Refer to illustration 10 below.

In areas with water of high mineral content, the use of an in-line water filter is recommended. Make sure the filter is positioned and accessible for replacement when necessary.

IMPORTANT NOTE: The ice maker will not fill with water immediately. Allow 24 hours for proper ice production. Let your customer know that the first container filled with ice should be discarded, as with any new connection there may be impurities in the ice from the water supply line.

⚠ WARNING

Shut power off at the circuit breaker before making electrical connection to the solenoid, if required.

IMPORTANT NOTE: Turn on the water supply and check all fittings for leaks. Make certain the electrical harness is attached to the solenoid.

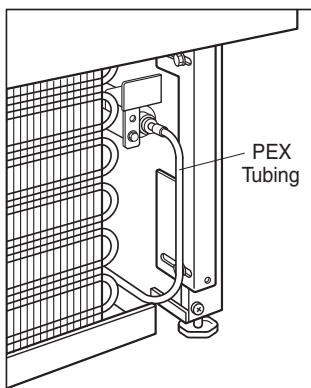

Illus. 10

Dimensions in parentheses are in millimeters unless otherwise specified.



KICKPLATE/GRILLE INSTALLATION

PANEL INSTALLATION

Once your Integrated unit is secured, the kickplate/grille can be installed. There is some adjustment to the mounting assembly so that this decorative piece can fit flush with the surrounding area. Refer to illustration 11 below.

The integrated design uses custom wood or other decorative panels and handles provided by the customer. Stainless steel panels are available as sales accessories. Contact your Sub-Zero dealer or check the accessories section of our website, subzero.com.

PANEL REQUIREMENTS

Door and drawer panels must be a minimum of 5/8" (16) thick.

The door panel cannot exceed 40 lbs (18 kg) and each drawer panel must not exceed 12 lbs (5 kg) for 27" (686) wide units. For 36" (914) wide units, the door panel weight limit is 53 lbs (24 kg) and 16 lbs (7 kg) for each drawer panel.

Turn power back on to the electrical outlet.

IMPORTANT NOTE: The unit must be allowed to have ventilation through the fins of the kickplate/grille. You may cover the solid area, but do not block the fins. The lower drawer panel may hang in front of the fins, but your base-board molding must not cover them.

IMPORTANT NOTE: The kickplate/grille must be removed for servicing. The floor cannot interfere with removal.

NOTE: The kickplate/grille can be painted another color, if you choose. Follow these easy steps:

- Rough up the surface to be painted with fine grit sandpaper.
- Wipe with alcohol to ensure that the surface is clean and dry.
- Use an appliance or industrial grade, oil base, high gloss enamel paint.

Before beginning installation, check the panels for the proper fit and finish desired.

Door and drawer panels must be a minimum of 5/8" (16) thick. The door panel cannot exceed 40 lbs (18 kg) and each drawer panel must not exceed 12 lbs (5 kg) for 27" (686) wide units. For 36" (914) wide units, the door panel weight limit is 53 lbs (24 kg) and 16 lbs (7 kg) for each drawer panel.

D-style pulls are recommended for handle hardware. Handles should be located on the opposite side from the hinge, centered on the cabinet door, and on the top center area of the drawer panel. Screw heads may have to be countersunk to ensure that the hardware does not interfere with the panels fitting flush with the unit's door or drawers.

It is recommended that the door panel of the tall unit be installed first and then the upper and lower drawer panels.

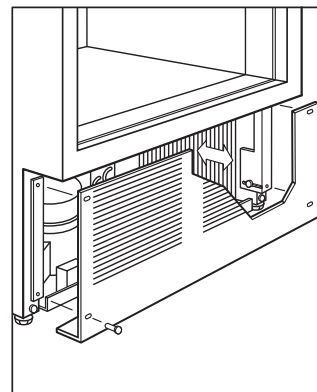

Illus. 11

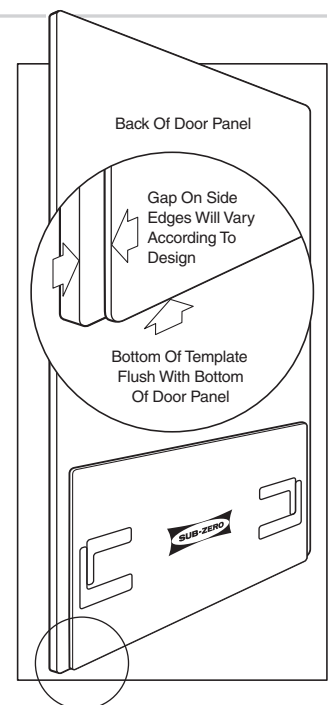

Illus. 12



If you have questions, contact your Sub-Zero dealer or cabinet supplier. Additional panel information can be found in the Sub-Zero Design Guide.

DOOR PANEL INSTALLATION

Remove the two pieces of mounting hardware attached to the front of the door and set aside.

Place the door panel lying face down on a protected surface to ensure that the front is not scratched or damaged.

Position the plastic template provided flush with the lower edge of the door. Be sure you are following the exact location for the right-hand (RH) or left-hand (LH) door position. Refer to illustration 12 on page 14.

IMPORTANT NOTE: The template has two usable sides, one side for the door and one for the drawers. Make sure you use the proper holes and side. Remember you are viewing the door panel from the back side in illustration 12 on page 14.

The overall size of the panel shown in illustration 13 is the minimum size necessary to cover the door of the unit. The exact measurements of your door panel may vary depending on the particular installation you are following.

Once you have located the proper position for the bracket, mark the pilot holes, remove the template and drill pilot holes for mounting the bracket. It is best to start with a few holes, position the bracket, drill the remaining pilot holes and then secure the mounting bracket with the #8 x 1/2" screws provided. Illustration 13 shows the mounting hardware location for door and drawer panels.

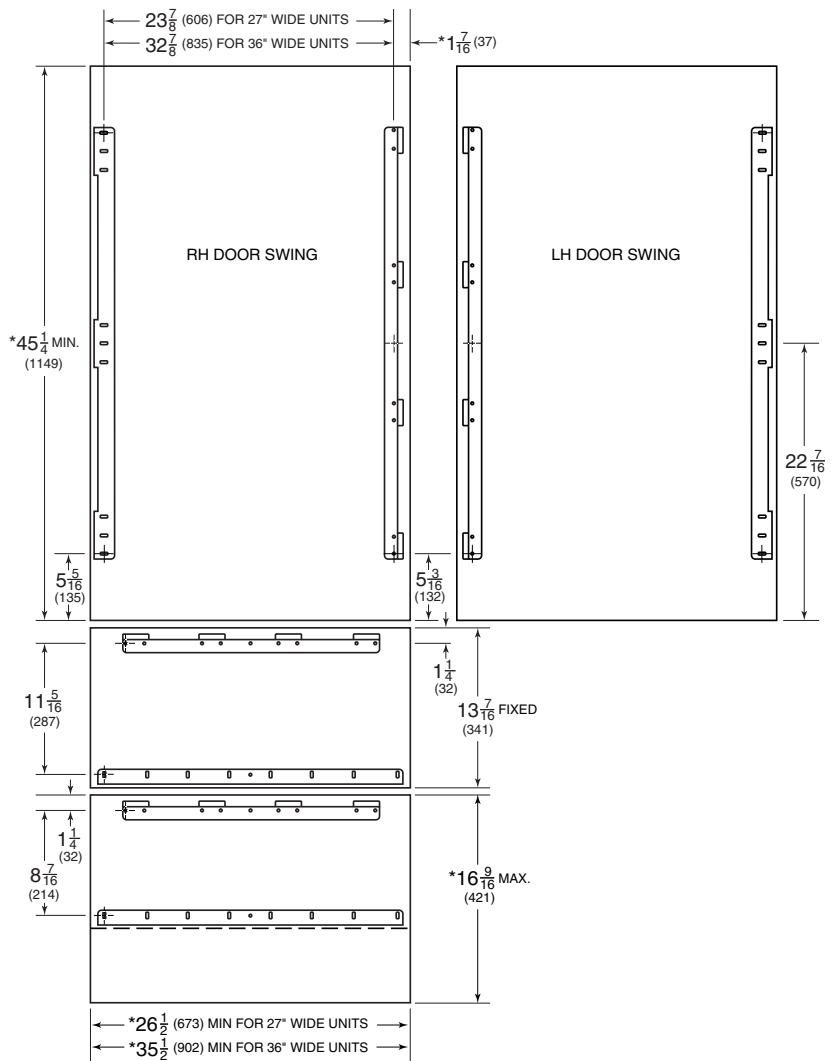

VIEW FROM BACK OF PANELS
*DIMENSIONS MAY VARY

Illus. 13

CAUTION
Exercise caution when drilling holes for mounting hardware. This is especially critical with inset panels.

Dimensions in parentheses are in millimeters unless otherwise specified.



PANEL INSTALLATION

PANEL REQUIREMENTS

Door and drawer panels must be a minimum of 5/8" (16) thick.

The door panel cannot exceed 40 lbs (18 kg) and each drawer panel must not exceed 12 lbs (5 kg) for 27" (686) wide units. For 36" (914) wide units, the door panel weight limit is 53 lbs (24 kg) and 16 lbs (7 kg) for each drawer panel.

Before attaching the door panel to the door, remove the outer screws from each of the three mounting positions along the hinge side of the door. Unscrew the three remaining screws in the center of each mounting position just enough that the slotted holes on the hinge side door panel bracket will slide under the heads. These positioning screws will support the door panel during installation and adjustment. Refer to illustration 14 below.

Install the door panel by engaging the tabbed bracket to the handle side of the door first and then sliding the hinge side mounting bracket onto the positioning screws on the hinge side of the door. The panel can be adjusted 1/4" (6) up and down and side to side.

Once the door panel is in place and adjusted correctly, attach the six remaining #10 x 1/2" screws to the hinge side mounting bracket and install the magnetic decorative caps as shown in illustration 14.

CAUTION
As the reveal between cabinets and the unit decreases, the potential exists for severe finger pinching if fingers are placed in the opening when the door is closing.

DRAWER PANEL INSTALLATION

Remove the mounting hardware provided and set aside. As with the door panel, you should work on the back side of each drawer panel and protect the fronts of these panels.

Position the top edge of the template flush with the top edge of each drawer. For the top drawer, there is only one location for the lower mounting bracket to be placed. However, the bottom drawer allows a second option, inverting the lower mounting bracket, depending on the height and thickness or detail of the panel. Refer to illustration 15 below.

Secure the template in place with tape or a small clamp and mark positions for the pilot holes. Remove the template and drill the pilot holes. Place the mounting brackets in the proper location with the tabbed bracket on top and 'L' bracket on the bottom of the panel. Fasten brackets securely with the #8 x 1/2" screws provided. Refer to illustration 16 below. Illustration 13 on page 15 also shows the mounting hardware location for drawer panels.

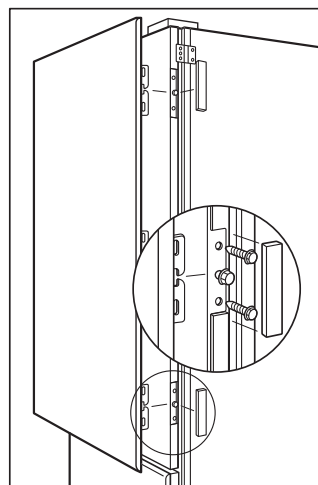

Illus. 14

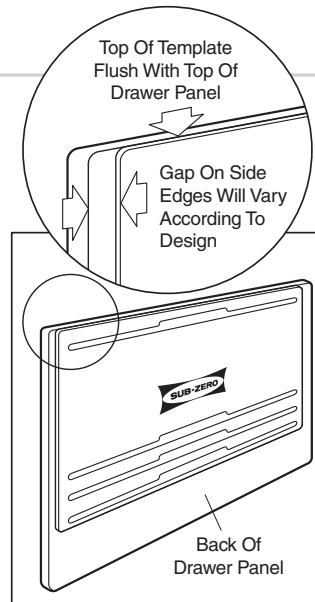

Illus. 15

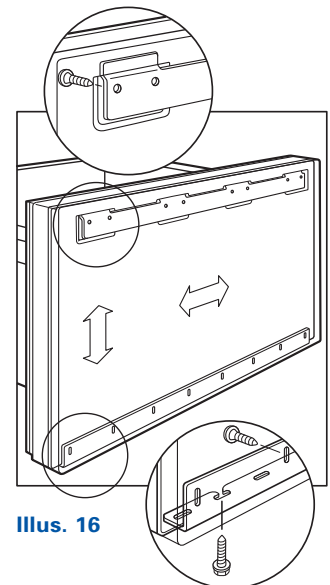

Illus. 16



DUAL INSTALLATIONS

To help with the placement of the drawer panels, examine the lower 'L' bracket and panel to determine the slotted holes on the bracket that will be used. Then position screws into the lower portion of the drawer that correspond with these slots. Leave these screws out just enough that the slotted holes in the bracket will slide under the heads.

With the two mounting brackets in place, install the drawer panel by engaging the top tabbed bracket first, then slide the lower 'L' bracket onto the positioning screws. Each drawer panel can be adjusted 1/4" (6) up and down and side to side. Fasten all screws to the lower 'L' bracket to secure the drawer panel. Refer to illustration 16 on page 16.

IMPORTANT NOTE: Once drawer panels have been adjusted for proper spacing, be sure to reconnect the control cable on the base unit only after you have installed the drawer. Refer to illustration 3 on page 10.

⚠ CAUTION
 Exercise caution when drilling holes for mounting hardware. This is especially critical with inset panels.

When two Integrated units are installed closer than 2" (51) to one another, it is necessary to use the Sub-Zero dual installation heater kit (BBDUAL or TTDUAL). The heater plate from this kit must be attached to the left side exterior of the right hand unit before the units are slid into position.

Contact your Sub-Zero dealer for the proper components and installation instructions. For questions relative to the installation, call Sub-Zero at 800-222-7820.

90-DEGREE DOOR STOP

All Integrated tall units have a 90° door stop built into the hinge system. Use the blade edge of a standard screwdriver and rotate the brass cam in the center portion of the hinge until you reach the stop. You must make this adjustment to both the bottom and top hinge. Refer to illustration 17 below.

OPTIONAL COMPONENTS

Optional installation components are available through your Sub-Zero dealer. You can also visit our website at subzero.com. For questions relative to the installation, call Sub-Zero at 800-222-7820.

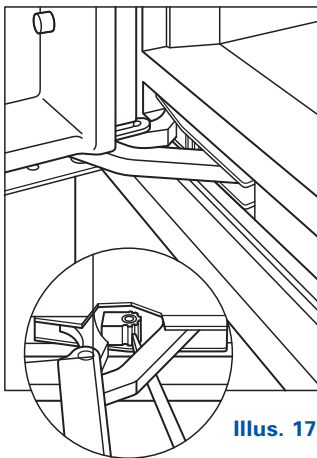

Illus. 17



INSTALLATION CHECKLIST

INSTALLATION CHECKLIST

The importance of the installation of the Sub-Zero Integrated unit cannot be overemphasized. Proper installation is the responsibility of the selling dealer or installer.

IMPORTANT NOTE: To ensure a safe and proper installation, the following checklist should be completed by the installer to ensure that no part of the installation has been overlooked.

Advise the homeowner to fill out and return all product registration forms. This will ensure that the customer information is in our database in the event service is required.

Any questions or problems about the installation should be directed to your Sub-Zero dealer or the Sub-Zero Customer Service Department at 800-222-7820. You can also visit our website at subzero.com.

INSTALLATION CHECKLIST

- Has the anti-tip bracket been installed properly and is it making contact with the unit?
- Is the unit level? Are all leveling legs making contact with the floor?
- Is the power cord plugged into a properly grounded 3-prong outlet, which has been installed in accordance with all applicable electrical codes?
- Is the water supply connected for units with an automatic ice maker? Have you checked for leaks?
- Has the kickplate/grille been installed properly?
- Are panels attached securely and properly aligned?
- Has the door been aligned for proper appearance and operation?
- Have all accessories been installed?
- Have any installation or service problems been noted on the product registration card? Has the registration card been mailed in?
- Have stainless steel panels been inspected for any imperfections? This is to be done by the dealer or installer with the customer upon completion of the installation.
NOTE: Classic, platinum and carbon stainless steel panels are covered by a limited 60-day parts and labor warranty for cosmetic defects.



SERVICE INFORMATION

If service is necessary, maintain the quality built into your Sub-Zero unit by calling a Sub-Zero authorized service center.

To obtain the name and number of a Sub-Zero authorized service center, check the Locator section of our website, subzero.com or call Sub-Zero Customer Service at 800-222-7820.

When calling for service, you will need the model and serial number of your unit. Both numbers are listed on the product rating plate located inside the cabinet, to the left of the upper drawer.

⚠ WARNING

If you are storing or disposing of your old refrigerator or freezer, please do it safely. Remove the doors or tightly secure the doors closed. Child entrapment accidents can be tragic.

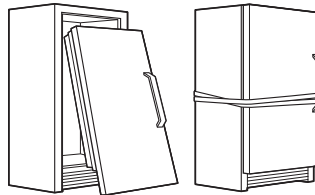

CONTACT INFORMATION

**Sub-Zero
Customer Service:
800-222-7820**

**Website:
subzero.com**

The information and images in this book are the copyright property of Sub-Zero Freezer Company, Inc. Neither this book nor any information or images contained herein may be copied or used in whole or in part without the express written permission of Sub-Zero Freezer Company, Inc.

©Sub-Zero Freezer Company, Inc. all rights reserved.

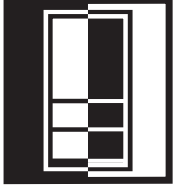

SUB-ZERO FREEZER COMPANY, INC. P. O. BOX 44130 MADISON, WI 53744-4130 800-222-7820 SUBZERO.COM

