

## INSTALLATION INSTRUCTIONS

### For Sharp Carousel® Built-in Kit Models RK56S27F or RK56S30F

S = STAINLESS

THIS KIT IS UL APPROVED TO ALLOW CERTAIN MICROWAVE OVENS TO BE INSTALLED ABOVE ANY ELECTRIC WALL OVEN. PLEASE SEE THE OPERATION MANUAL REGARDING APPROVED BUILT-IN APPLICATIONS.

#### IMPORTANT:

This Built-in Kit is designed for and approved only for those Sharp Microwave Ovens specifying Built-In Kit RK56S27F or RK56S30F. Refer to operation manual for approved models.

#### IMPORTANT NOTES TO THE INSTALLER

- PLEASE READ THESE INSTRUCTIONS THOROUGHLY BEFORE BEGINNING INSTALLATION.
- Observe all governing codes, ordinances, and safety instructions.
- Be sure to leave these instructions with the consumer.
- Be sure to DISCONNECT THE PLUG of the microwave oven from the electrical outlet before installing the Built-in Kit. Remove the Carousel turntable from the oven cavity.
- Because the kit includes metal parts, due caution should be used in handling and installation to avoid the possibility of injury.

ITEM	PART NAME	QTY
A	FRONT FRAME RK56S27F: FDECAB252MRK0 RK56S30F: FDECAB253MRK0	1
B	BACK FRAME RK56S27F: FDECAB255MRK0 RK56S30F: FDECAB255MRK0	1
C	EXHAUST DUCT ASSEMBLY PDUC-B188MRP0	1
D	SCREW D: XTSS740P20000	2

ITEM	PART NAME	QTY
E	SCREW E: XOPS740P16000	8
F	AIR DEFLECTOR: RK56S27F: PREF-B038MRP0 RK56S30F: PREF-B039MRP0	2

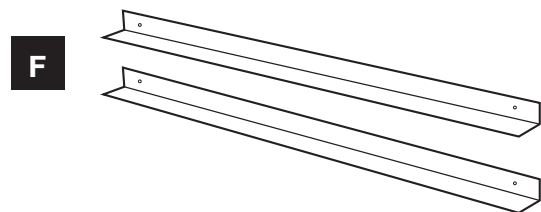
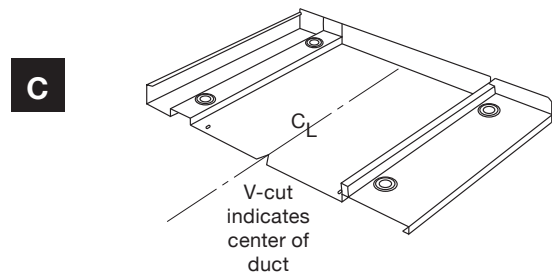
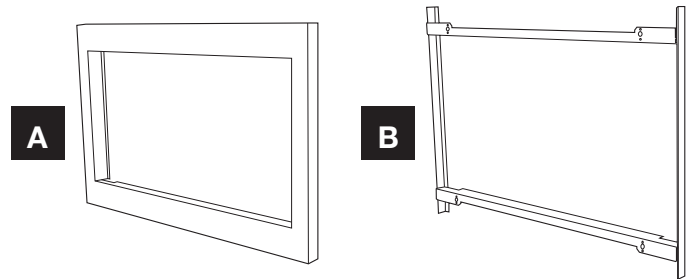

# STANDARD INSTALLATION INSTRUCTIONS

## STEP 1 - CABINET OR WALL OPENING

The opening in the wall or cabinet must be within the following dimensions:

OPENING	RK56S27F, RK56S30F
Height (A)	14 <sup>1</sup> / <sub>2</sub> " - 15 <sup>3</sup> / <sub>4</sub> " (368.3 - 400 mm)
Width (B)	24 <sup>3</sup> / <sub>4</sub> " (628.7 mm)
Minimum Depth (C)	20" (508 mm)

Outlet should **NOT** be in the shaded area as indicated in Figure 1.

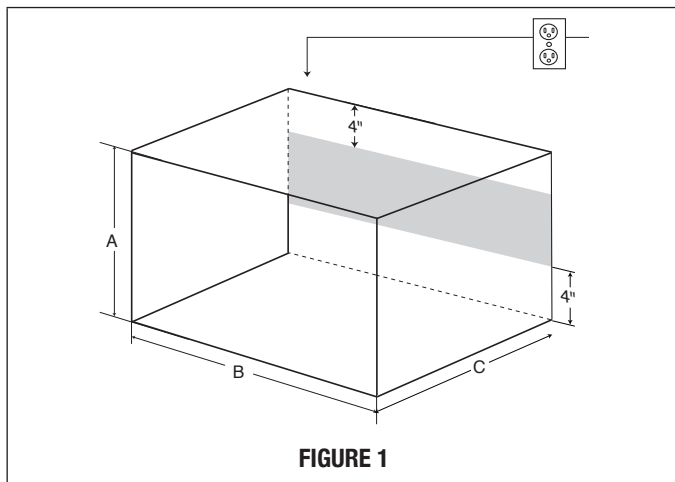

FIGURE 1

### NOTES

- Please allow minimum 3" wood gap between the microwave oven cutout and the appliance cutout below the microwave oven. See Figure 2.

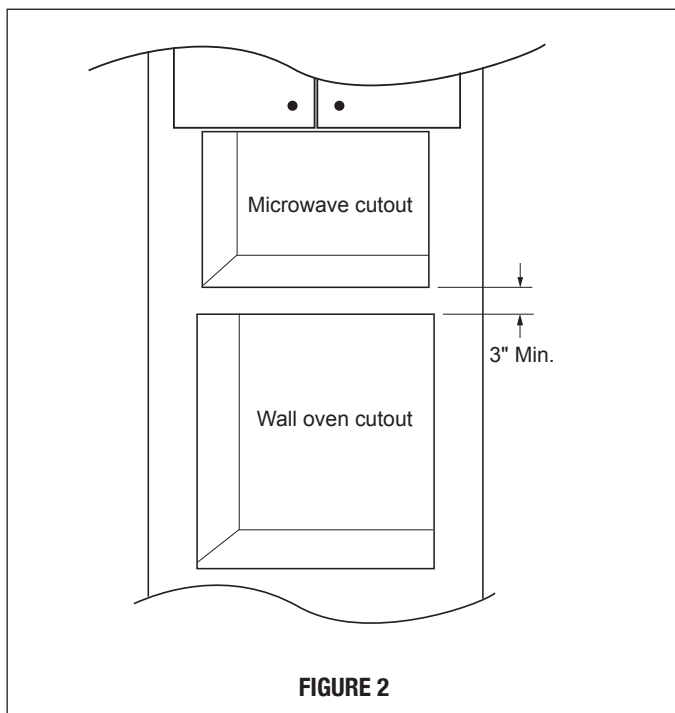

FIGURE 2

- If the dimension of DEPTH (C) is more than 21" (533.4 mm), the outlet location may be any area on the rear wall.
- The floor of the opening should be constructed of plywood strong enough to support the weight of the oven and floor load (about 100 pounds/45 kg). The floor should be level and 90° with the face of the cabinet for proper installation and operation of the oven. Be sure to check the local building code as it may require that the opening be enclosed with sides, ceiling and rear partition. The proper functioning of the oven does not require the enclosure.

## STEP 2 - EXHAUST DUCT ASSEMBLY INSTALLATION

1. Place the EXHAUST DUCT ASSEMBLY in the center of the opening. Align the front edge of the duct with the front of the cabinet.
2. Secure the EXHAUST DUCT ASSEMBLY with 2 SCREWS D. See Figure 3.

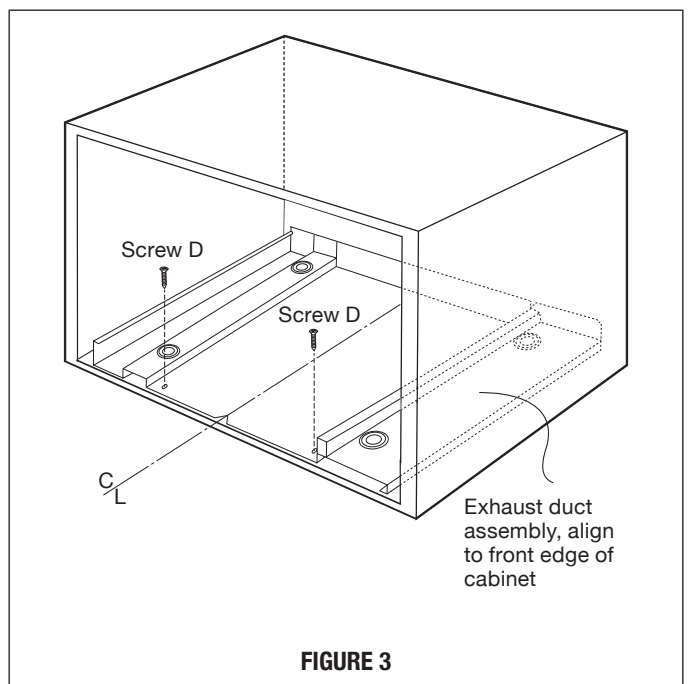
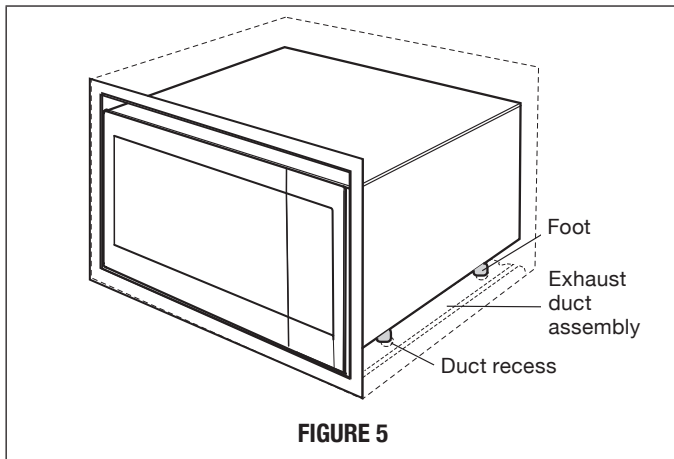
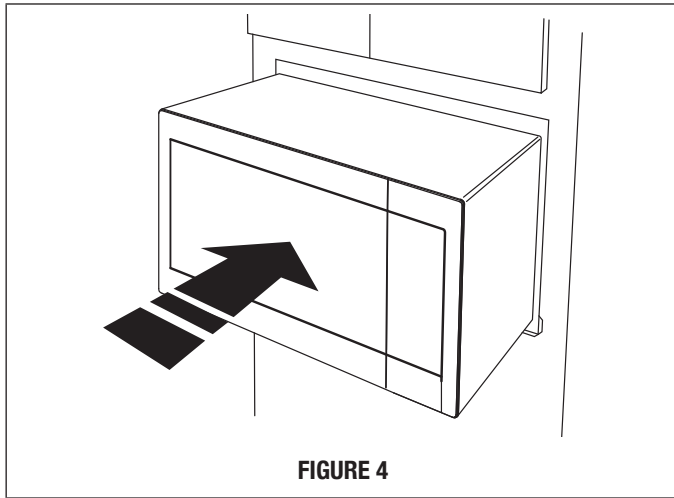

FIGURE 3

## STEP 3 - FRAME INSTALLATION

1. Place the oven adjacent to the wall or cabinet opening. Plug the POWER CORD into the electrical outlet.
2. Carefully guide the assembled oven into the prepared opening. Slide the oven onto the EXHAUST DUCT ASSEMBLY. See Figure 4. Avoid pinching the cord between the oven and the wall. Adjust the position of the oven so that the feet of the oven are fitted into the recesses of the EXHAUST DUCT ASSEMBLY and the door opens properly. See Figure 5.

# STANDARD INSTALLATION INSTRUCTIONS



3. **DISASSEMBLY:** The FRONT FRAME and BACK FRAME come pre-assembled with ball studs engaged in the receivers. Separate the FRONT FRAME from the BACK FRAME. Place the assembly facedown onto a protected surface. At the location of the ball stud, insert a flathead screwdriver between the FRONT FRAME and the BACK FRAME and gently pry up to disengage the ball stud from the receiver. Repeat for each corner. See Figure 6.

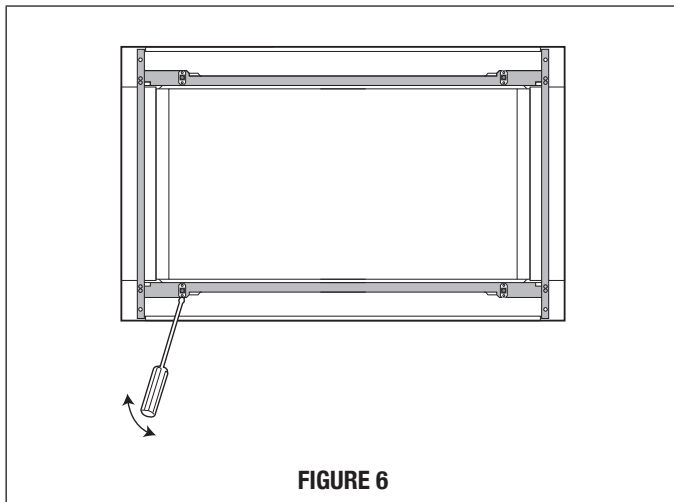

4. **BACK FRAME INSTALLATION:** Position BACK FRAME with equal space top to bottom, side to side. Mark for 4 holes, center punch and pre-drill the cabinet with  $\frac{1}{16}$ " drill bit. Secure frame with 4 SCREWS E. See Figure 7.

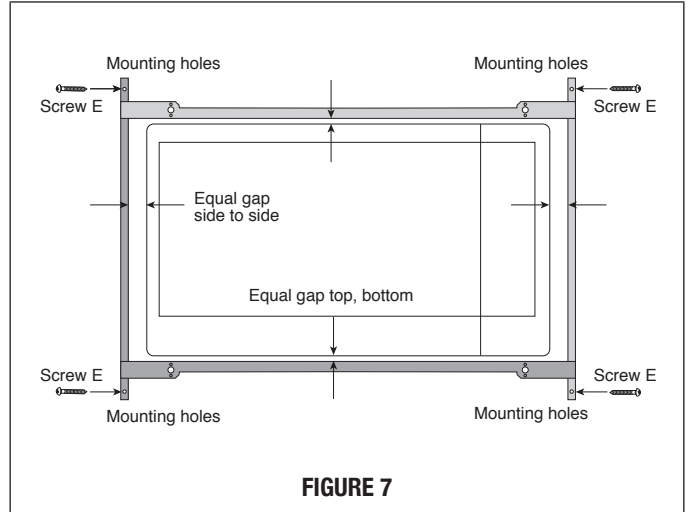

5. **FRONT FRAME INSTALLATION:** Place the FRONT FRAME onto the BACK FRAME and align ball studs and receivers. Secure the FRONT FRAME to the BACK FRAME by firmly pushing the FRONT FRAME onto the BACK FRAME engaging the 4 snap attachments. See Figures 8-9.

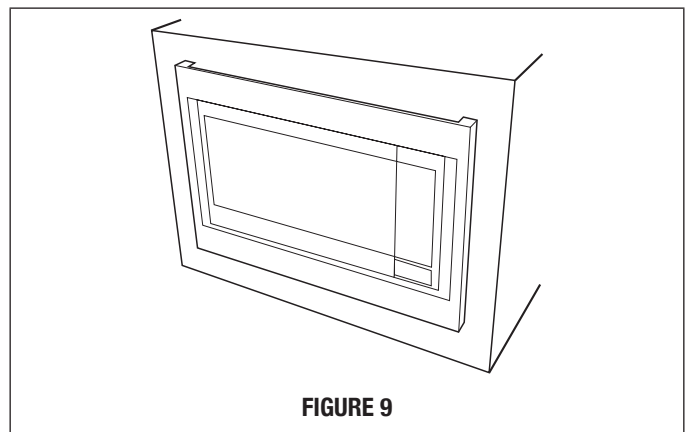
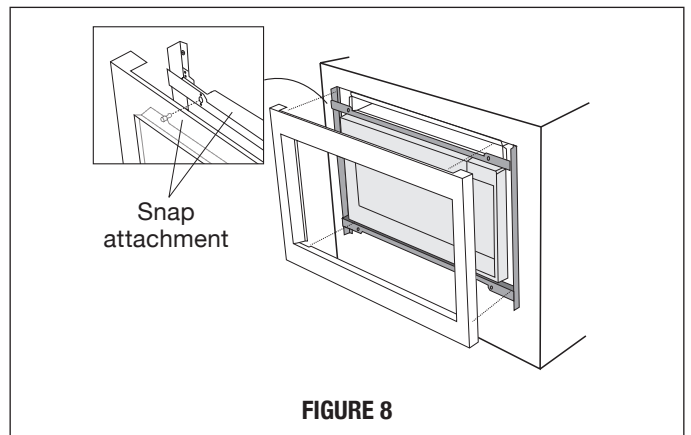

# FLUSH INSTALLATION INSTRUCTIONS

## STEP 1 - CABINET OR WALL OPENING

The opening in the wall or cabinet must be within the following dimensions:

OPENING	RK56S27F	RK56S30F
A	24 <sup>3</sup> / <sub>4</sub> " (628.7 mm)	24 <sup>3</sup> / <sub>4</sub> " (628.7 mm)
Width (B)	27 <sup>1</sup> / <sub>8</sub> " (689 mm)	30 <sup>1</sup> / <sub>8</sub> " (765.2 mm)
Height (C)	22 <sup>7</sup> / <sub>16</sub> " (569.9 mm)	22 <sup>7</sup> / <sub>16</sub> " (569.9 mm)
D	1 <sup>3</sup> / <sub>16</sub> " (30.2 mm)	2 <sup>11</sup> / <sub>16</sub> " (67.5 mm)
E	3 <sup>1</sup> / <sub>4</sub> " (82 mm)	3 <sup>1</sup> / <sub>4</sub> " (82 mm)
F	1 <sup>1</sup> / <sub>2</sub> " (38.8 mm)	1 <sup>1</sup> / <sub>2</sub> " (38.8 mm)
G	4" (101.6 mm)	4" (101.6 mm)
Minimum Depth (I)	20" (508 mm)	20" (508 mm)

Outlet should **NOT** be in the shaded area H as indicated in Figure 1.

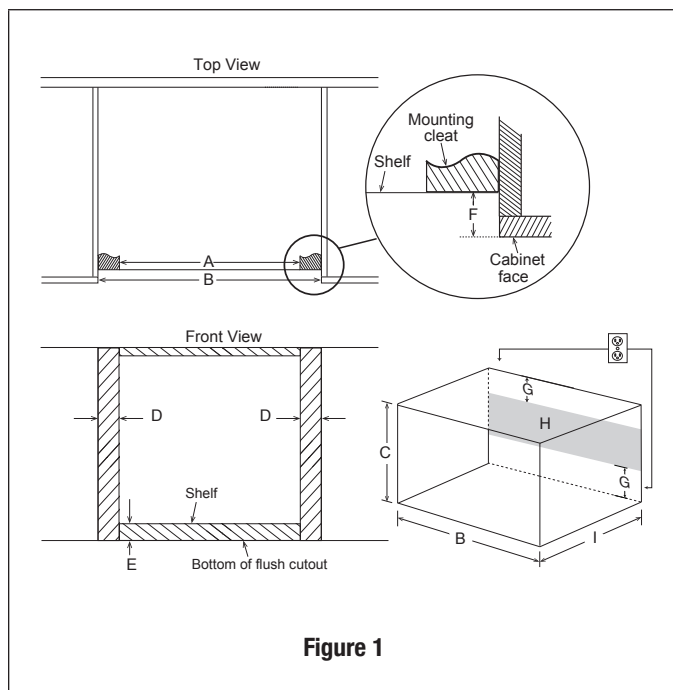

Figure 1

## NOTES

Dimension C above will result in 1<sup>1</sup>/<sub>4</sub>" (31.8 mm) spaces above and below the trim to allow for necessary intake and exhaust air flow to ensure appliance does not overheat. **Do not reduce this spacing** as doing so will void the warranty for any issues resulting from a lack of airflow.

## NOTES

- Please allow minimum 3" (76 mm) wood gap between the microwave oven cutout and the appliance cutout below the microwave oven. See Figure 2.

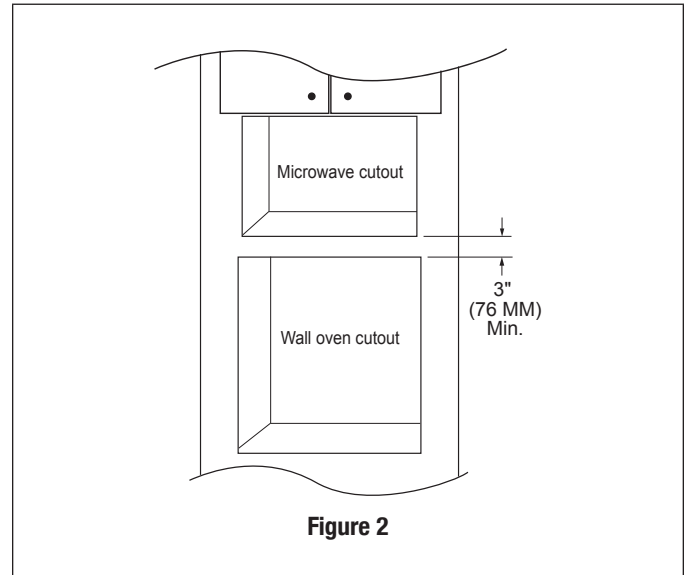

Figure 2

- The floor of the opening should be constructed of plywood strong enough to support the weight of the oven and floor load (about 100 pounds/45 kg). The floor should be level and 90° with the face of the cabinet for proper installation and operation of the oven. Be sure to check the local building code as it may require that the opening be enclosed with sides, ceiling and rear partition. The proper functioning of the oven does not require the enclosure.

# FLUSH INSTALLATION INSTRUCTIONS

## STEP 2 - EXHAUST DUCT ASSEMBLY INSTALLATION

1. Place the Exhaust Duct Assembly in the center of the opening. Align the front edge of the duct with the front of the cabinet. Align the front edge of the right side of the duct with the front of the shelf. See Figure 3.
2. Secure the Exhaust Duct Assembly with 2 SCREWS D. See Figure 3.

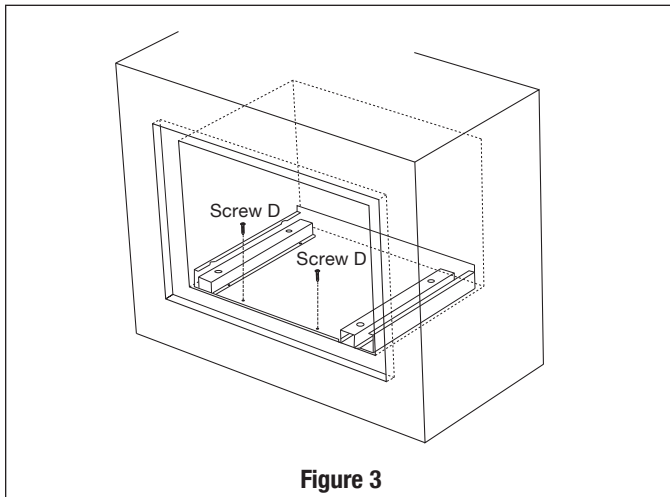

Figure 3

## STEP 3 - FRAME INSTALLATION

1. Place the oven adjacent to the wall or cabinet opening. Plug the power cord into the electrical outlet.
2. Carefully guide the assembled oven into the prepared opening. Slide the oven onto the Exhaust Duct Assembly. See Figure 4. Avoid pinching the cord between the oven and the wall. Adjust the position of the oven so that the feet of the oven are fitted into the recesses of the Exhaust Duct Assembly and the door opens properly. See Figure 5.

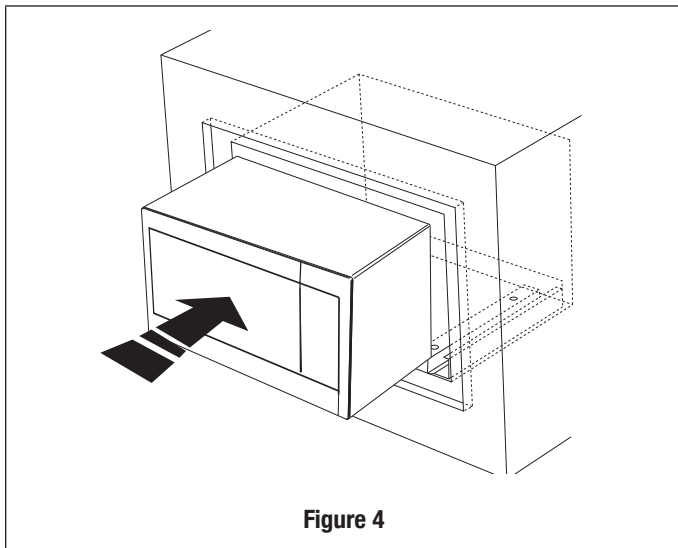

Figure 4

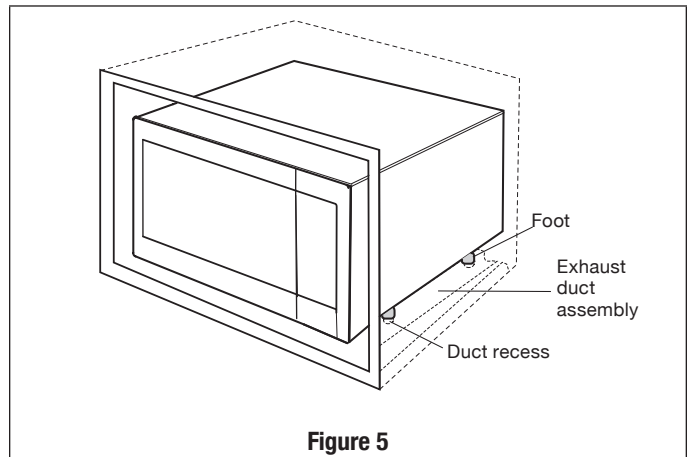

Figure 5

3. **DISASSEMBLY:** The FRONT FRAME and BACK FRAME come pre-assembled with ball studs engaged in the receivers. Separate the FRONT FRAME from the BACK FRAME. Place the assembly facedown onto a protected surface. At the location of the ball stud, insert a flathead screwdriver between the FRONT FRAME and the BACK FRAME and gently pry up to disengage the ball stud from the receiver. Repeat for each corner. See Figure 6.

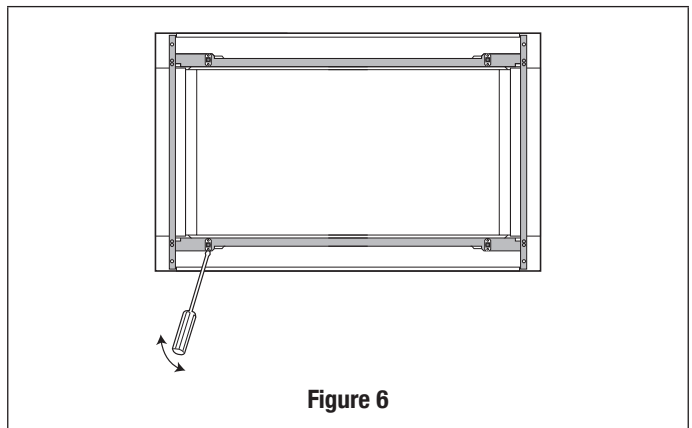
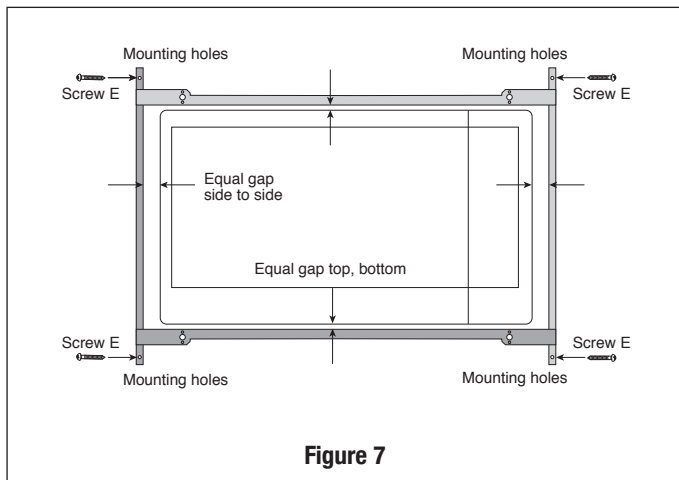

Figure 6

# FLUSH INSTALLATION INSTRUCTIONS

4. **BACK FRAME INSTALLATION:** Position BACK FRAME equal space top to bottom, side to side. Mark for 4 holes on the installed wood cleats, center punch and pre-drill with  $\frac{1}{16}$ " drill bit. Secure frame with 4 SCREWS E. See Figure 7.



5. Install Air Deflectors top and bottom. Center (left and right) the Air Deflectors above and below the installed BACK FRAME. Secure AIR DEFLECTORS with 4 SCREWS E. See Figure 8. Mark holes and pre-drill the wood cleats with  $\frac{1}{16}$ " drill bit.

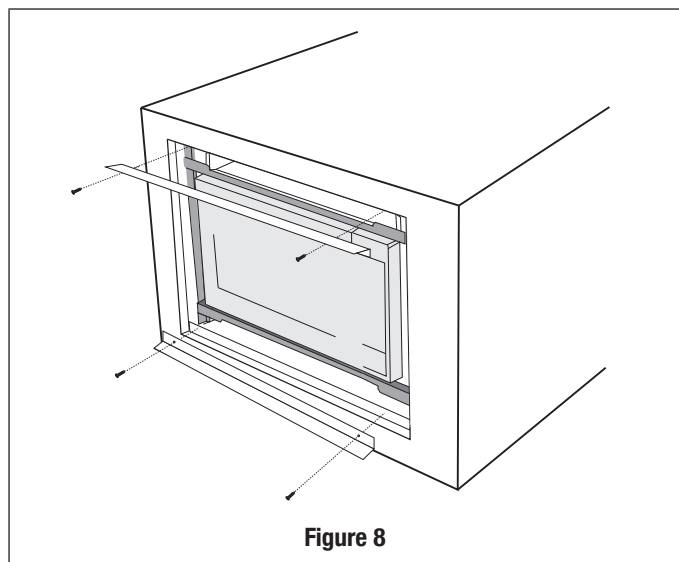

6. **FRONT FRAME INSTALLATION:** Place the FRONT FRAME onto the BACK FRAME and align ball studs and receivers. Secure the FRONT FRAME to the BACK FRAME by firmly pushing the FRONT FRAME onto the BACK FRAME engaging the 4 snap attachments. See Figures 9-10.

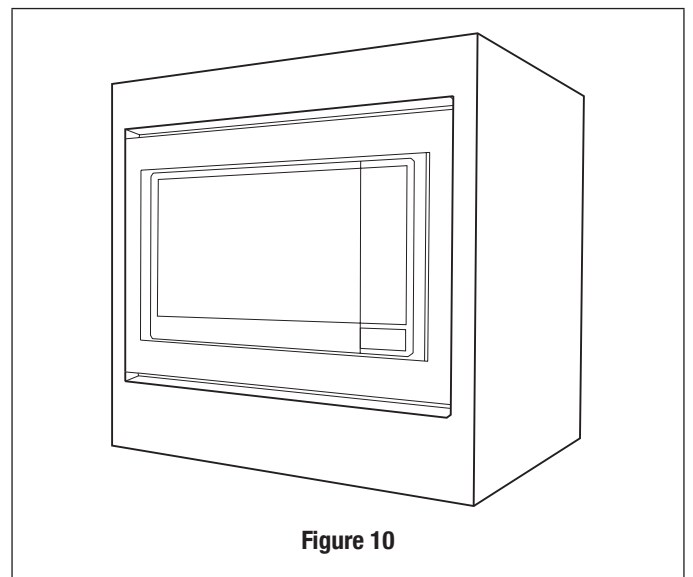
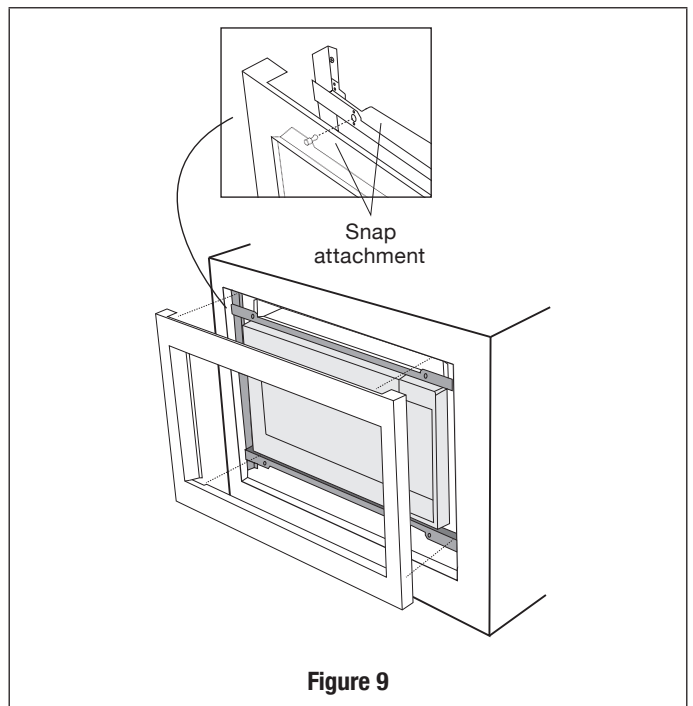



**SHARP**<sup>®</sup>

For any other assistance or information about this kit,  
please call Sharp's Customer Assistance Center at  
**1-800-BE-SHARP (1-800-237-4277)**

---

**SHARP ELECTRONICS CORPORATION**  
100 Paragon Drive, Montvale, New Jersey 07645

TINSEB578MRR1  
12-4-19