

**3045CLR • 45 cm Clear Ice Machine • Modular 3000 Series**

**FEATURES & BENEFITS**



INTEGRATED SOLID



STAINLESS SOLID

<b>PERFORMANCE</b>	<ul style="list-style-type: none"> <li>• Daily ice production of up to 27 kg of ice</li> <li>• Up to 14 kg in ice storage capacity</li> <li>• Clear ice cube dimensions: 22 mm W x 22 mm H x 22 mm L</li> <li>• Clear ice cube fullness can be adjusted</li> <li>• Silent mode temporarily suspends ice making for 3 hours</li> <li>• U-Select® Control with digital OLED display is conveniently located on upper face of unit</li> <li>• Indicator alert notifies user when cleaning is needed</li> <li>• Easy clean process only lasts 45 minutes</li> </ul>
<b>INTERIOR/EXTERIOR</b>	<ul style="list-style-type: none"> <li>• Black interior is illuminated with LED theatre lighting</li> <li>• Clear heavy duty ice scoop included</li> <li>• Drain required; factory installed drain line</li> <li>• Model can be ordered with factory installed P60 drain pump if gravity drain is not accessible</li> <li>• Door swing is field reversible. Unit is shipped with door installed right-hand hinged</li> </ul>
<b>INTEGRATION</b>	<ul style="list-style-type: none"> <li>• To achieve a stainless steel finish, a Euro Style panel accessory must be ordered and installed on an integrated model. Euro Style Panel Accessory must be installed on corresponding unit type (Frame/Solid)</li> <li>• Robust, concealed and covered hinges with built-in door stop and closer</li> <li>• Adjustable grille/fascia can be shifted front-to-back and up-and-down</li> <li>• Grille/fascia can accept a custom integrated plinthe</li> <li>• Integrated model requires 20 mm custom panel of your choice, or can accept U-Line Euro Style Stainless Steel Panel Accessory (must be ordered separately)</li> <li>• Four independently adjustable leveling legs; rear legs are adjustable from the front for ease of installation</li> </ul>

**MODEL DETAILS**

Model	Voltage/Hz	Door Swing	Pump	Finish	Shipping Weight
U-3045CLRINT-00B	220-240 / 50	Field Reversible	-	Integrated Solid	49 kg
3045CLRINT-40B	220-240 / 50	Field Reversible	Pump Included	Integrated Solid	52 kg
U-3045CLRINT-00B and U-ESP45S	220-240 / 50	Field Reversible	-	Stainless Solid*	53 kg
3045CLRINT-40B and U-ESP45S	220-240 / 50	Field Reversible	Pump Included	Stainless Solid*	56 kg

**ACCESSORIES**

Model	Description	Finish	Shipping Weight
U-ESP45S	Euro Style Panel Solid 45 cm	Stainless Solid	4 kg
37050	Clear Ice Machine Cleaner (1 box of 6 packets)	na	0,5 kg
ULN-P60-20	Drain Pump (220-240 v)	na	3 kg

\*To achieve a stainless steel finish, a Euro Style panel accessory must be ordered and installed on an integrated model. Euro Style Panel Accessory must be installed on corresponding unit type (Frame/Solid).

**Modular 3000 Series • 45 cm Clear Ice Machine • 3045CLR**
**NICHE / RECESS**

Dimensions shown apply to Integrated (INT) models with a 20 mm integrated panel/frame installed (applies to U-Line's Euro Stainless Steel Panel Accessory).

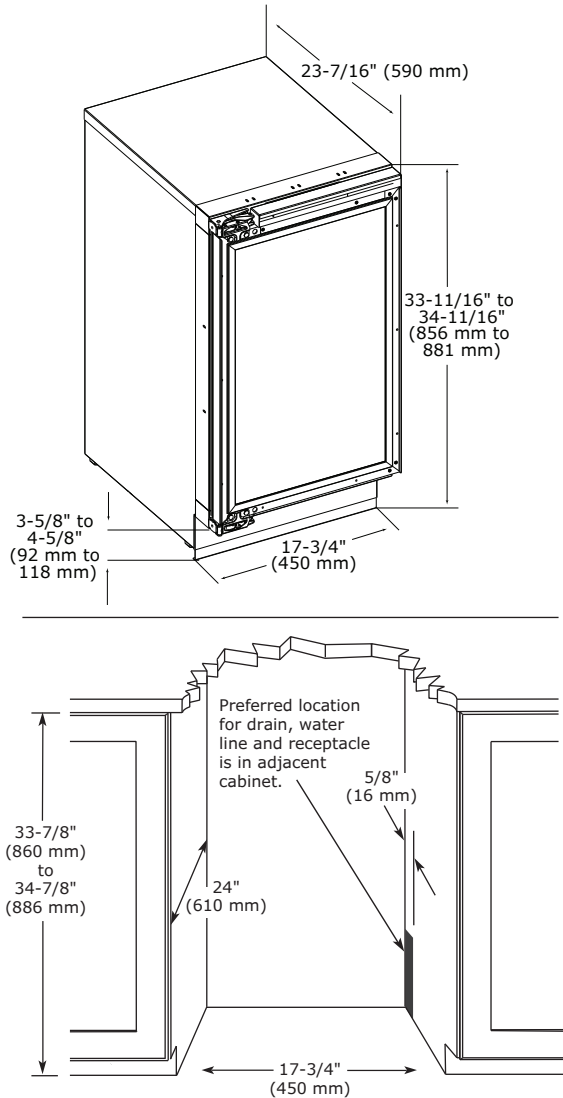
**PRODUCT FICHE**

Model	3045CLR
Category	N/A
Energy efficiency class on a scale of A+++ to G	N/A
Energy consumption in kWh per year	N/A
Total volume: fridge compartment (net)	N/A
Total volume: wine compartment (net)	N/A
Total volume: freezer compartment (net)	N/A
Frost-free compartment	Yes
Temperature rise time in event of blackout (hrs)	N/A
Climate class	ST
Noise emissions	N/A
Dimensions: width	450 mm
Dimensions: depth	610 mm
Dimensions: height	856 mm
Net weight: solid door (with pump)	48 kg
Net weight: solid door (without pump)	45 kg
Panel type	Solid Panel (-00 Suffix)
Panel thickness	20 mm
Panel height	762 mm
Panel width	445 mm
Rated frequency	50 Hz
Rated voltage	220-240 v
Refrigerant charge	149 g
Foam blowing agent	HFO-1233zd
Marine capable	No

**INSTALLATION NOTES**

No additional clearance around sides, top or rear of unit is needed for ventilation.

Do not obstruct front grille/fascia air flow.

For cabinet depths less than 620 mm, electrical socket must be located in the adjacent cabinet or recess in the wall. The power cord length is 180 cm.

- Water pressure requirement - 1,38 to 8,27 bar (20 to 120 PSI)
- Water flow requirement - water supply must be capable of maintaining 1,38 to 8,27 bar (20 to 120 PSI) for 1,5 minutes with a flow rate of 0,6 litres per minute. Recovery rate/interval at a maximum of every 12 minutes
- Water use - 1 litre of water for each harvest of ice. Recovery rate/interval at a maximum of every 12 minutes
- No additional clearance is needed for water pipe connection.
- A gravity drain may be used if the drain line has at least a 2 cm drop per 100 cm of run. If this requirement can not be met, a pump model must be ordered.

Please visit [U-Line.com](http://U-Line.com) to view this model's User Guide. All specifications are subject to change without notice.