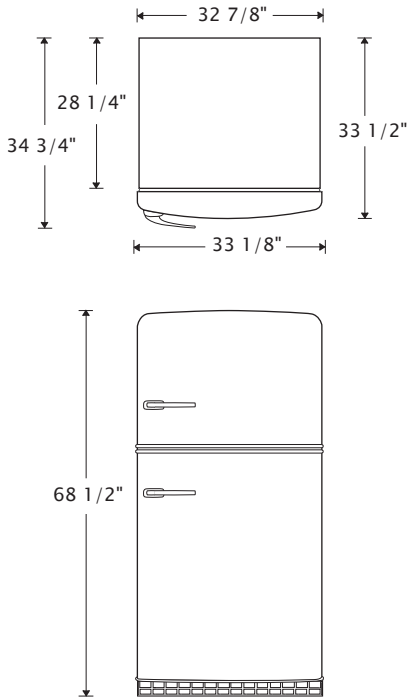
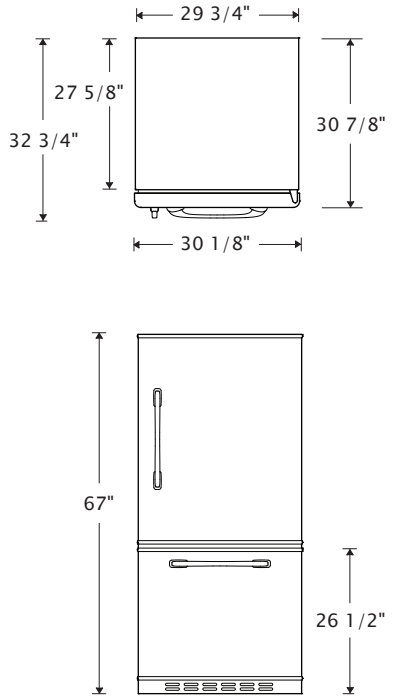

## REFRIGERATOR FEATURES AND SPECIFICATIONS

ORIGINAL SIZE	MODEL: (21TF)	RETROPOLITAN	MODEL: (19BF)
			
Total Capacity	20.5 cu. ft.	Total Capacity	18.5 cu. ft.
Refrigerator Capacity	14.4 cu. ft.	Refrigerator Capacity	12.9 cu. ft.
Freezer Capacity	6.2 cu. ft.	Freezer Capacity	5.6 cu. ft.
Clearance: Back	1/2"	Clearance: Back	1/2"
Clearance: Side	1/4"	Clearance: Side	1/4"
Side Clearance for door to open 90°	4 1/2"	Side Clearance for door to open 90°	3 1/2"
Adjustable Rollers	Standard	Adjustable Rollers	Standard
Energy Guide (kWh/year)	436	Energy Guide (kWh/year)	521
Electrical	115V, 60Hz, AC only, 15 or 20 amp fused	Electrical	115V, 60Hz, AC only, 15 or 20 amp fused
<p>FEATURES:</p> <p>Stamped Metal Body, Chrome Trim, 2 Half-Width Clear Crisper Drawers, Gallon Door Storage, Temperature Management System, 1 Fixed Full-Width Freezer Shelf, 3 Easy-Clean Spill-Proof Glass Shelves, LED Interior Lighting, Optional Ice Maker, Available Left Hand Hinge, 1 Year Parts and Labor Warranty</p>		<p>FEATURES:</p> <p>Stamped Metal Body, Chrome Trim, Gallon Door Storage, 2 Half-Width Clear Crisper Drawers, Four Half-Width Adjustable Glass Shelves, Temperature Management System, Slide-Out Upper Freezer Basket, Glide-Out Freezer Basket with Organizer, Optional Ice Maker, Available Left Hand Hinge, 1 Year Parts and Labor Warranty</p>	

## REFRIGERATOR FEATURES AND SPECIFICATIONS

### 24" RETRO FRIDGE

MODEL:  
(11TF)

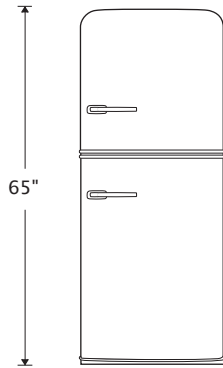
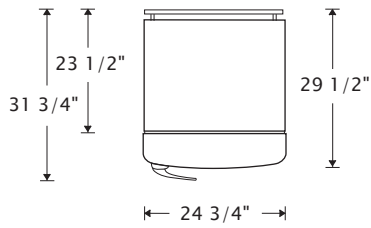

### STUDIO SERIES

MODEL:  
(14TF)

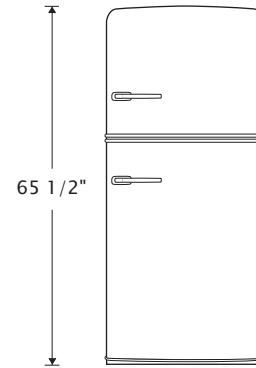
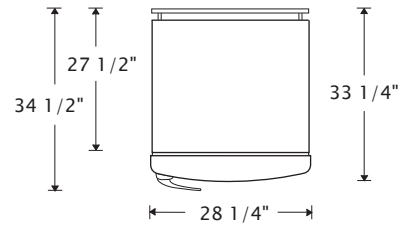

Total Capacity	10.7 cu. ft.
Refrigerator Capacity	7.74 cu. ft.
Freezer Capacity	2.94 cu. ft.
Clearance: Back	1/2"
Clearance: Side	1/4"
Side Clearance for door to open 90°	5"
Adjustable Rollers	Standard
Energy Guide (kWh/year)	338
Electrical	115V, 60Hz, AC only, 15 or 20 amp fused

**FEATURES:**

Stamped Metal Body, Chrome Trim, Full-Width Fixed Refrigerator Door Storage, Temperature Management System, Optional Ice Maker, Available Left Hand Hinge, 1 Year Parts and Labor Warranty

Total Capacity	14.4 cu. ft.
Refrigerator Capacity	10.6 cu. ft.
Freezer Capacity	3.8 cu. ft.
Clearance: Back	1/2"
Clearance: Side	1/4"
Side Clearance for door to open 90°	4 1/2"
Adjustable Rollers	Standard
Energy Guide (kWh/year)	373
Electrical	115V, 60Hz, AC only, 15 or 20 amp fused

**FEATURES:**

Stamped Metal Body, Chrome Trim, 2 Half-Width Crisper Drawers, Adjustable Wire Shelving, Available Left, Hand Hinge, Temperature Management System, Optional Ice Maker, 1 Year Parts and Labor Warranty



TEL: 1-877-842-3269

EMAIL: [info@bigchill.com](mailto:info@bigchill.com)

WEB: [www.bigchill.com](http://www.bigchill.com)

## FEATURES AND SPECIFICATIONS

### DISHWASHER

MODEL:  
(DW24)

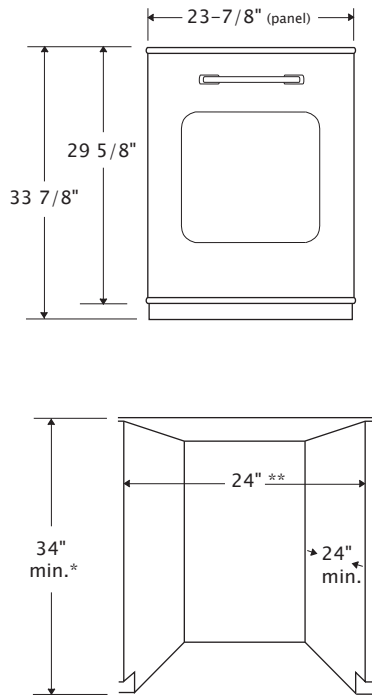

### COUNTERTOP MICROWAVE

MODEL:  
(MICRO16)

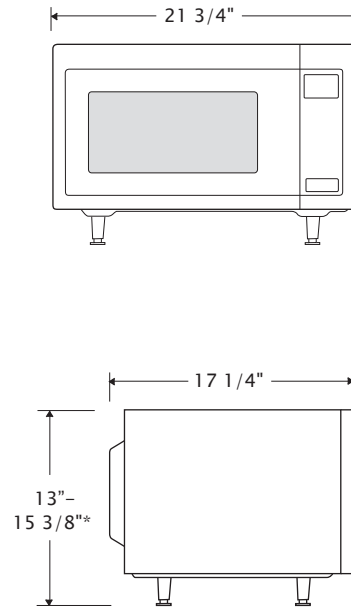

Capacity	14 Place Settings
Cycles	6
Cycles	Tough, Normal, Light, Express Wash, Rinse Only
Cycle Options	6
Energy Guide	270 (kWh/year) – Energy Star Qualified
Warranty	One Year Parts and Labor
Electrical	15 or 20 Amp, 120 V, 60 Hz, AC only.

Capacity	1.6 cubic feet
Output Power	1200 Watts
Cooking Uniformity	13 1/2" Diameter Turntable
Warranty	One Year Parts and Labor
Weight	38 lbs
Electrical	15 Amp, 120 V, 60 Hz, AC only.

**FEATURES:**

- Stamped Metal Body
- Authentic chrome trim
- Whisper Quiet® Plus (46 dBA) Sound Reduction
- Stainless Steel Interior
- Hard food disposer
- 3 Racks
- Energy Star Qualified

**FEATURES:**

With up to 1,200 watts of cooking power, you'll have the power you need to prepare all types of food. Sensor cooking tracks the progress of your food and automatically adjusts cooking time as needed to deliver optimal results. A recessed glass turntable also makes cooking with larger items, like cooking bowls, easy so you can prepare caramel corn, party mix and soups in the microwave.

\* Measured from the lowest point on the underside of countertop.

\*\* Minimum, measured from narrowest point of opening.

\*Microwave can be ordered with or without legs. Height will vary between 13"–15 3/8" depending on selection.



TOLL FREE: 1-877-842-3269

EMAIL: [info@bigchill.com](mailto:info@bigchill.com)

WEB: [www.bigchill.com](http://www.bigchill.com)

# INDUCTION COOKTOP FEATURES AND SPECIFICATIONS

## 30" Retro Induction Cooktop

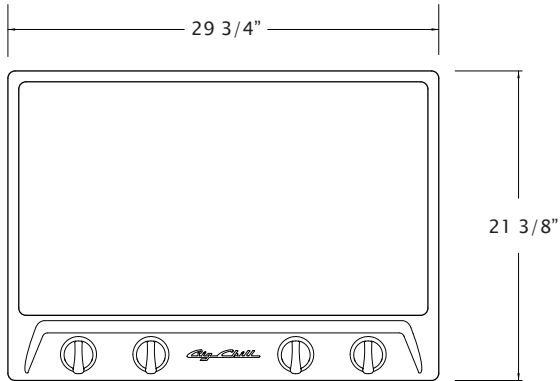

TOP VIEW

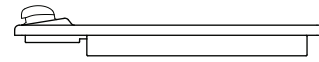

SIDE VIEW

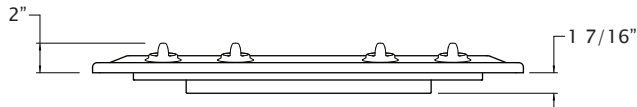
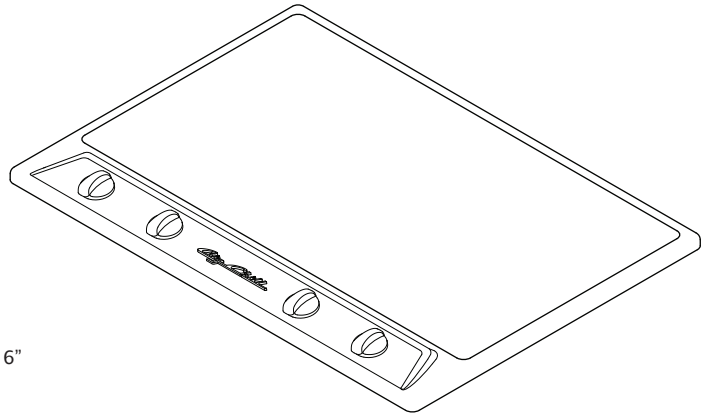

FRONT VIEW

Dimensions	2"H x 29 3/4"W x 21 3/8"D
Electrical	240/ 208 VAC, 40 Amps
	Max Power: 7400 W

### FEATURES:

9 Heat Levels, Power Booster, Boils a gallon of water in under 5 minutes, Large 9" induction elements provide up to 3,700 watts of cooking power per zone, Available in 8 standard colors and 200 custom colors

### INSTALL NOTES:

Allow 30"-36" between stove top and bottom of range hood (or per your local city codes).



TOLL FREE: 1-877-842-3269

EMAIL: [info@bigchill.com](mailto:info@bigchill.com)

WEB: [www.bigchill.com](http://www.bigchill.com)

# 30" GAS RANGE FEATURES AND SPECIFICATIONS

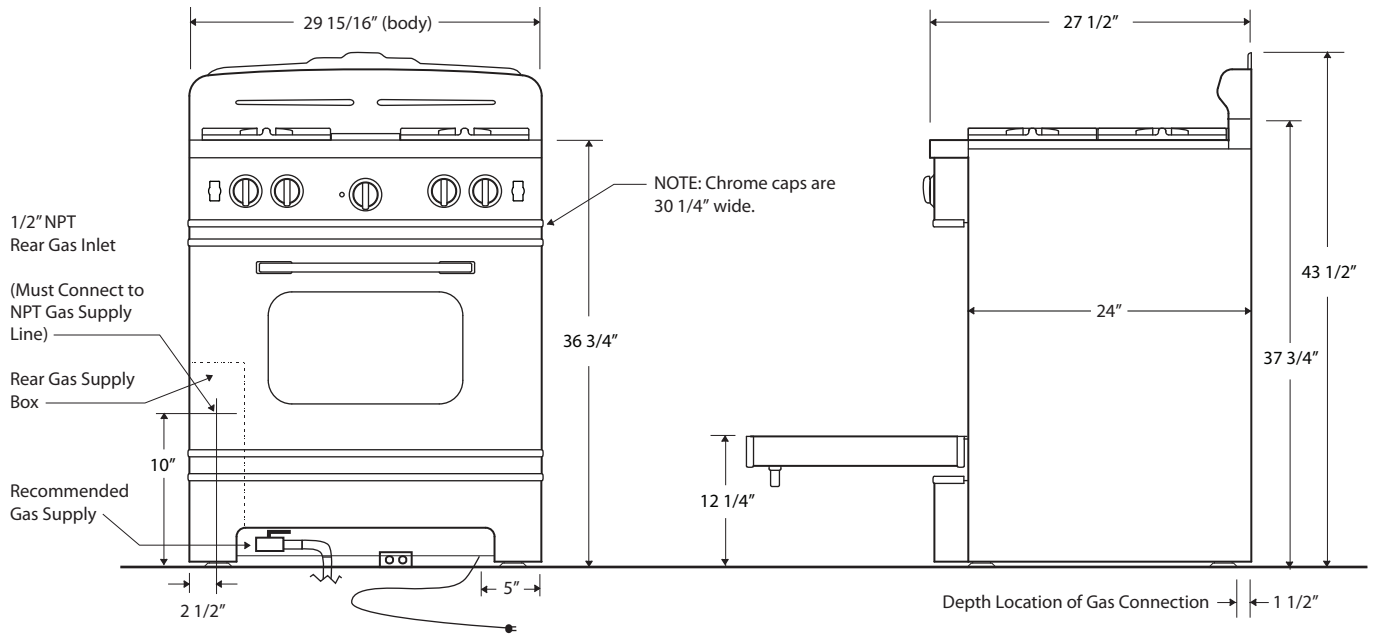

Front Burners	15,000 BTU	*Easy to clean Sealed Burner Top
Back Left Burner (Simmer)	6,000 BTU	*Automatic electronic ignition and re-ignition system
Back Right Burner	10,000 BTU	*24" depth for compatibility with standard kitchen cabinetry
Infrared Broiler Rating	15,000 BTU	*Convection fan
Oven Burner Rating	30,000 BTU	*Full Extension oven rack
Electrical Requirements	120 VAC, 15 Amps,	*Heavy-duty, commercial stainless steel construction
*(Unit must be on a non-GFI, dedicated outlet)	Single Phase	*1 year parts and labor warranty
Operating Gas Pressure	NAT: 5.0" WC LP: 10.0" WC	OVEN CAPACITY: The cavity design of the oven provides the most precise temperature control, which delivers even heat distribution resulting in versatile performance. It has the largest oven capacity available on a 30" range and will accommodate a full-size commercial 18" x 26" baking sheet.
Install Clearance:	0" Side Cabinet 0" Back Wall 6" Side Wall	INFRARED BROILER: Because of its popularity in the commercial market, the direct-fired ceramic infrared broiler is standard on all residential ranges. The large burner produces 1850 F of intense, searing heat close to the burner, while effecting a gentler broiling for foods placed farther away. The broiler is fully recessed into the oven's top to create maximum cooking space.

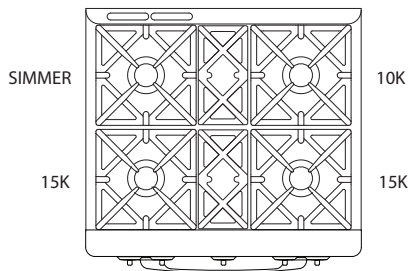

### FULL MOTION GRATES:

Bring sauce to a boil while stirring on a front burner, then slide it to the rear to simmer while you saute up front! Our full motion grates allow you to easily reposition pots and pans from front to rear burners without lifting. The grates are also oversized to accommodate the largest stock pots and saute pans.



# 30" ELECTRIC RANGE FEATURES AND SPECIFICATIONS

MODEL:  
BCR130

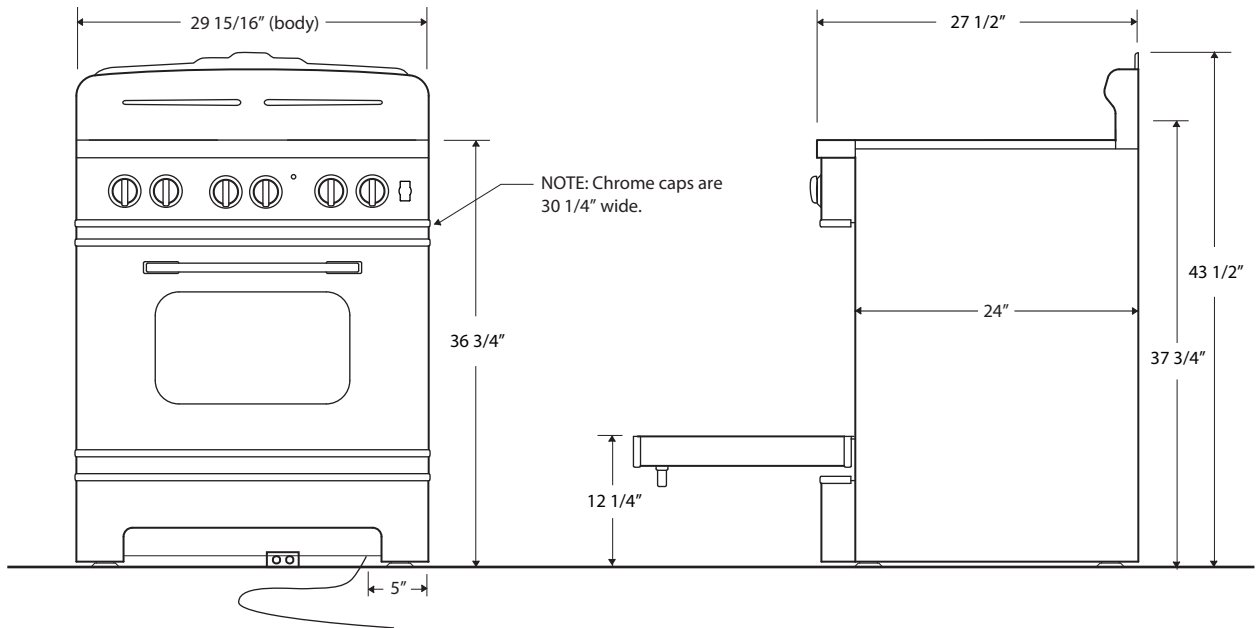

Front Left Burner	1850 Watts
Front Right Burner	1400 Watts
Back Left Burner	1850 Watts
Back Right Burner	2300 Watts
Broiler Element	5000 Watts
Oven Bake Element	2500 Watts
Oven Capacity	4 cu.ft.
Electrical Requirements	240 Volt, 60 Hertz,
*(Unit must be on a non-GFI, dedicated outlet)	35 Amp, Single Phase

*5 selectable cooking modes, including preheat
*Powerful 2500 watt top and bottom heating elements
*True convection mode with 1800 watt convection element
*Full Extension oven rack
*Heavy-duty, commercial stainless steel construction
*Easy to clean cavity
*1 year parts and labor warranty

Install Clearance:	0" Side Cabinet
	0" Back Wall
	6" Side Wall

**OVEN CAPACITY:**  
The cavity design of the oven provides the most precise temperature control, which delivers even heat distribution resulting in versatile performance. It has the largest oven capacity available on a 30" range and will accommodate a full-size commercial 18" x 26" baking sheet.

**INDUCTION COOKTOP:**  
\*4 cooktop induction zones that automatically adjust to the size of the pan  
\*9 heat settings on each cooktop burner  
\*\*"Power Booster" function that boils a gallon of water in less than 5 minutes!  
\*\*"Heat Accelerator" function to kickstart the cooking process on all cooking zones  
\*\*"Keep Warm" function allows two levels of even, low temperatures

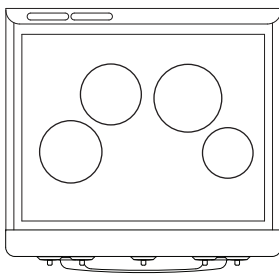

7.9" Diameter  
1850 W  
7.9" Diameter  
1850 W

8.6" Diameter  
2300 W  
6.3" Diameter  
1400 W

**ROBUST SAFETY FEATURES:**  
\*\*"Knob Lock" function (knob can be electronically locked)  
\*Pan detection technology: Unit won't start unless a pan is on unit  
\*Hot surface indicator light to indicate when it's safe to touch



## 36" GAS RANGE FEATURES AND SPECIFICATIONS

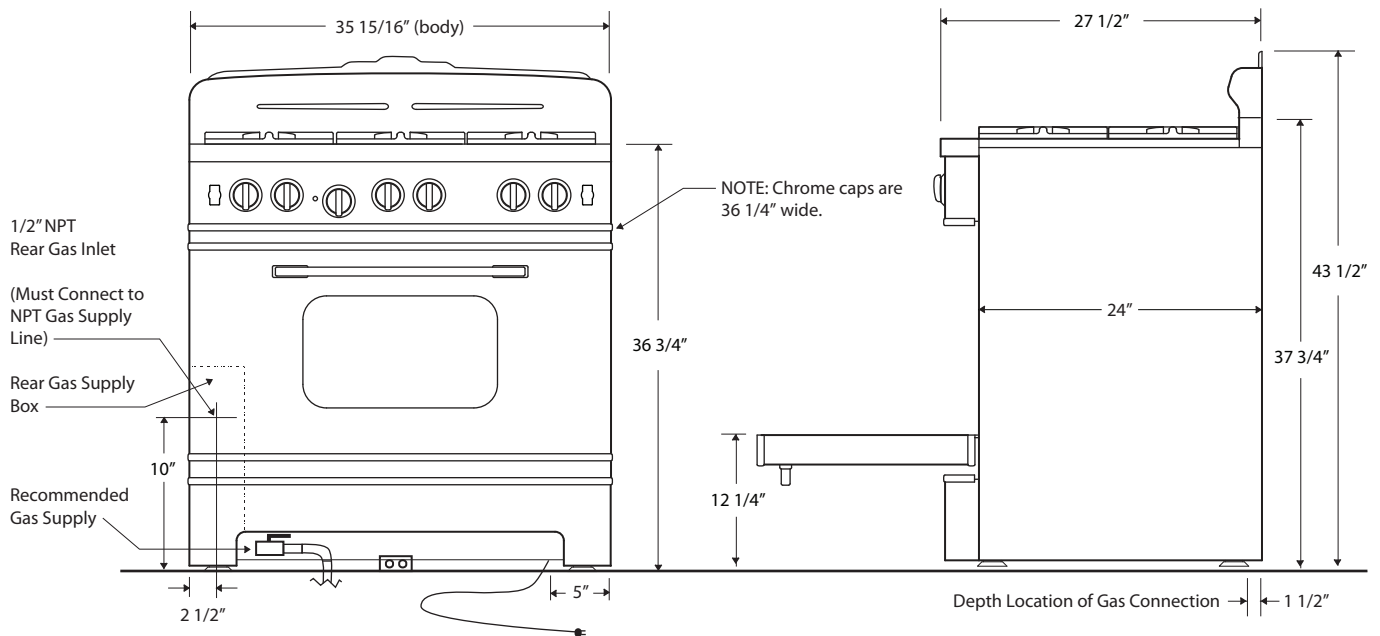

Front Burners	15,000 BTU	*Easy to clean Sealed Burner Top
Back Left Burner (Simmer)	6,000 BTU	*Automatic electronic ignition and re-ignition system
Back Right Burners	10,000 BTU	*24" depth for compatibility with standard kitchen cabinetry
Infrared Broiler Rating	15,000 BTU	*Convection fan
Oven Burner Rating	30,000 BTU	*Full Extension oven rack
Electrical Requirements	120 VAC, 15 Amps,	*Heavy-duty, commercial stainless steel construction
*(Unit must be on a non-GFI, dedicated outlet)	Single Phase	*1 year parts and labor warranty
Operating Gas Pressure	NAT: 5.0" WC LP: 10.0" WC	<b>OVEN CAPACITY:</b>
Install Clearance:	0" Side Cabinet 0" Back Wall 6" Side Wall	The cavity design of the oven provides the most precise temperature control, which delivers even heat distribution resulting in versatile performance. It has the largest oven capacity available on a 36" range and will accommodate a full-size commercial 18" x 26" baking sheet.

### INFRARED BROILER:

Because of its popularity in the commercial market, the direct-fired ceramic infrared broiler is standard on all residential ranges. The large burner produces 1850 F of intense, searing heat close to the burner, while effecting a gentler broiling for foods placed farther away. The broiler is fully recessed into the oven's top to create maximum cooking space.

### FULL MOTION GRATES:

Bring sauce to a boil while stirring on a front burner, then slide it to the rear to simmer while you saute up front! Our full motion grates allow you to easily reposition pots and pans from front to rear burners without lifting. The grates are also oversized to accommodate the largest stock pots and saute pans.

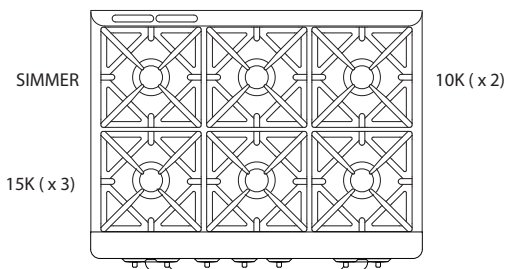

# RANGE HOOD FEATURES AND SPECIFICATIONS

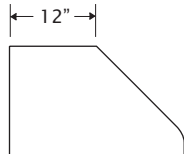
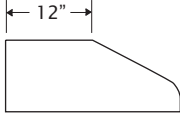
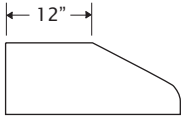
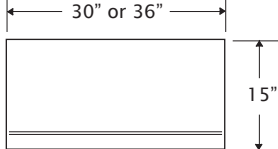
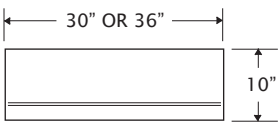
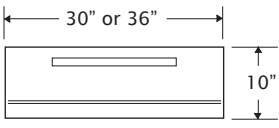
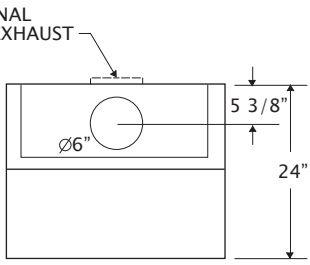
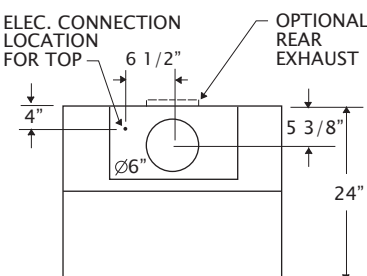
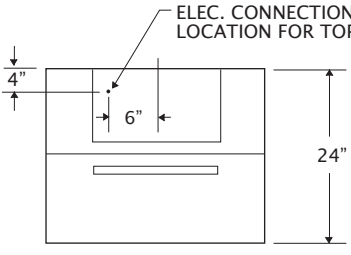
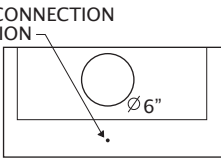
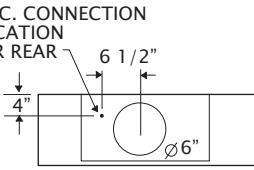
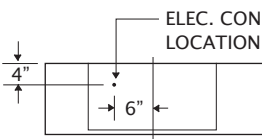
15" Hood MODELS: (BCH3015) (BCH3615)	10" Hood MODELS: (BCH3010) (BCH3610)	10" Hood—RECIRCULATING MODELS: (BCH3010R) (BCH3610R)			
 SIDE VIEW	 SIDE VIEW	 SIDE VIEW			
 FRONT VIEW	 FRONT VIEW	 FRONT VIEW			
 TOP VIEW	 TOP VIEW	 TOP VIEW			
 BACK VIEW	 BACK VIEW	 BACK VIEW			
Dimensions	15"H x 30"W(OR 36") x 24"D	Dimensions	10"H x 30"W(OR 36") x 24"D	Dimensions	10"H x 30"W(OR 36") x 24"D
Vent	External, Reversible top or rear exhaust.	Vent	External, Reversible top or rear exhaust.	Vent	Recirculating
Blower	600 CFM/ 3-Speed	Blower	600 CFM/ Variable Speed	Blower	520 CFM/ Variable Speed
Electrical	120 VAC, 15 Amps	Electrical	120 VAC, 15 Amps	Electrical	120 V, 15 Amps

**FEATURES:**

Commercial grade 18 gauge 300 stainless steel construction, Welded seamless corners, Dishwasher safe stainless steel baffle filters, Variable or 3-speed blower control, Halogen lamps with dimmer control, Largest filtered capture in the industry

**INSTALL NOTES:**

Allow 30"-36" between stove top and bottom of range hood (or per your local city codes).

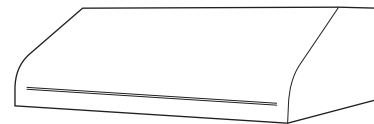



# RANGE HOOD FEATURES AND SPECIFICATIONS

## 12" Tall Bungalow Hood

MODELS:  
(BCH3012)  
(BCH3612)

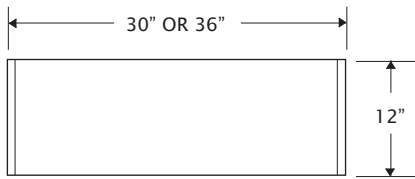

FRONT VIEW

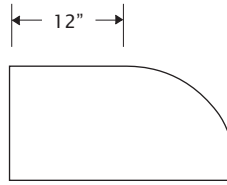

SIDE VIEW

OPTIONAL  
REAR EXHAUST

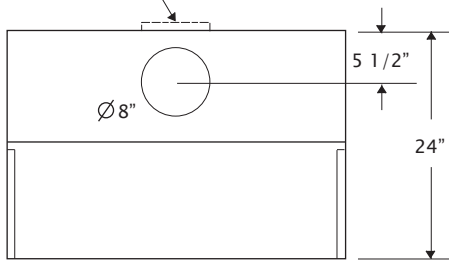

TOP VIEW

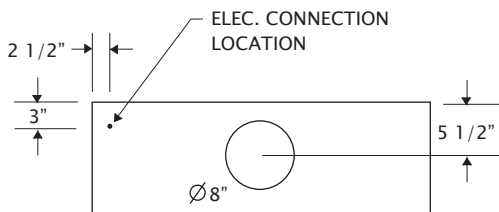

BACK VIEW

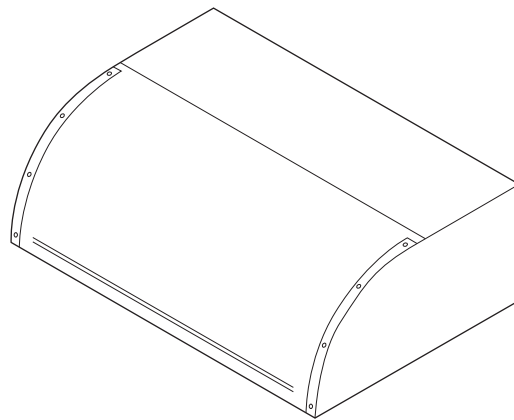

Dimensions	12"H x 30"W (OR 36") x 24"D
Vent	External, Reversible top or rear exhaust.
Blower	600 CFM / 3-Speed
Electrical	120 VAC, 15 Amps

### FEATURES:

Commercial grade 18 gauge 300 stainless steel construction, Welded seamless corners, Dishwasher safe stainless steel baffle filters, 3-Speed blower control, Halogen lamps with dimmer control, Largest filtered capture in the industry

### INSTALL NOTES:

Allow 30"-36" between stove top and bottom of range hood (or per your local city codes).



*Big Chill*

TOLL FREE: 1-877-842-3269

EMAIL: [info@bigchill.com](mailto:info@bigchill.com)

WEB: [www.bigchill.com](http://www.bigchill.com)

# WALL OVEN FEATURES AND SPECIFICATIONS

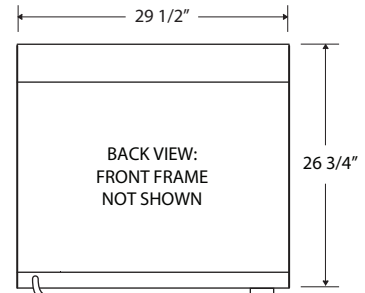
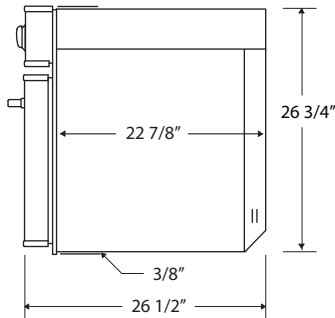
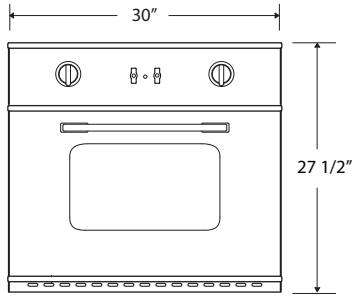

LOCATION OF ELECTRICAL CONNECTION. ATTACHED TO 20" FLEXIBLE CONDUIT.

## FEATURES

- \*4 cu.ft. Large Oven Capacity
- \*2500 watt bake element
- \*5000 watt broil element
- \*Selectable convection mode
- \*Coved corner interior with removable bottom for easy cleaning
- \*Heavy duty, full extension oven racks
- \*1 year parts and labor warranty
- \*Traditional black/white stippled interior
- \*Heavy-duty, stainless steel construction
- \*Can be installed in wall or island
- \*800 watt rear element
- \*Simple controls
- \*Can be stacked to double capacity

## Oven Capacity

The cavity design of the oven provides the most precise temperature control, which delivers even heat distribution resulting in versatile performance. It has the largest oven capacity available on a 30" range and will accommodate a full-size commercial 18" x 26" baking sheet.

## Electrical Requirements

240 Volt, 60 Hertz, 35AMPS, Single Phase  
 \*(Unit must be on a non-GFI, dedicated outlet)



## CABINET CLEARANCES

\*RECOMMENDED CABINET WIDTH IS 33"

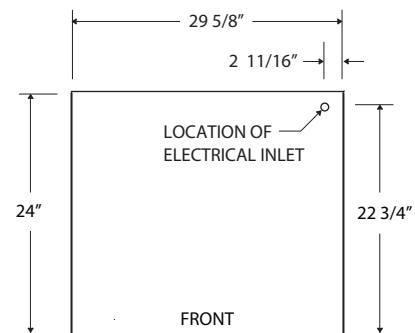
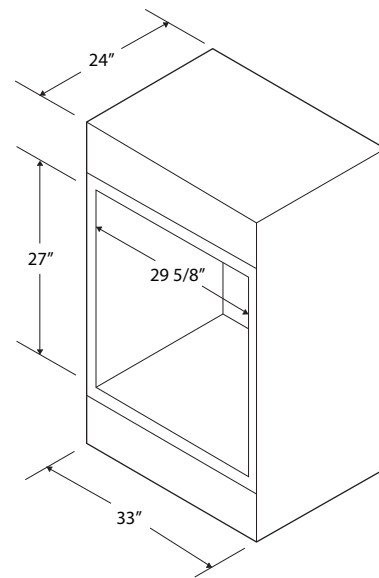

TOP VIEW CABINET

# 30" CLASSIC RANGE FEATURES AND SPECIFICATIONS

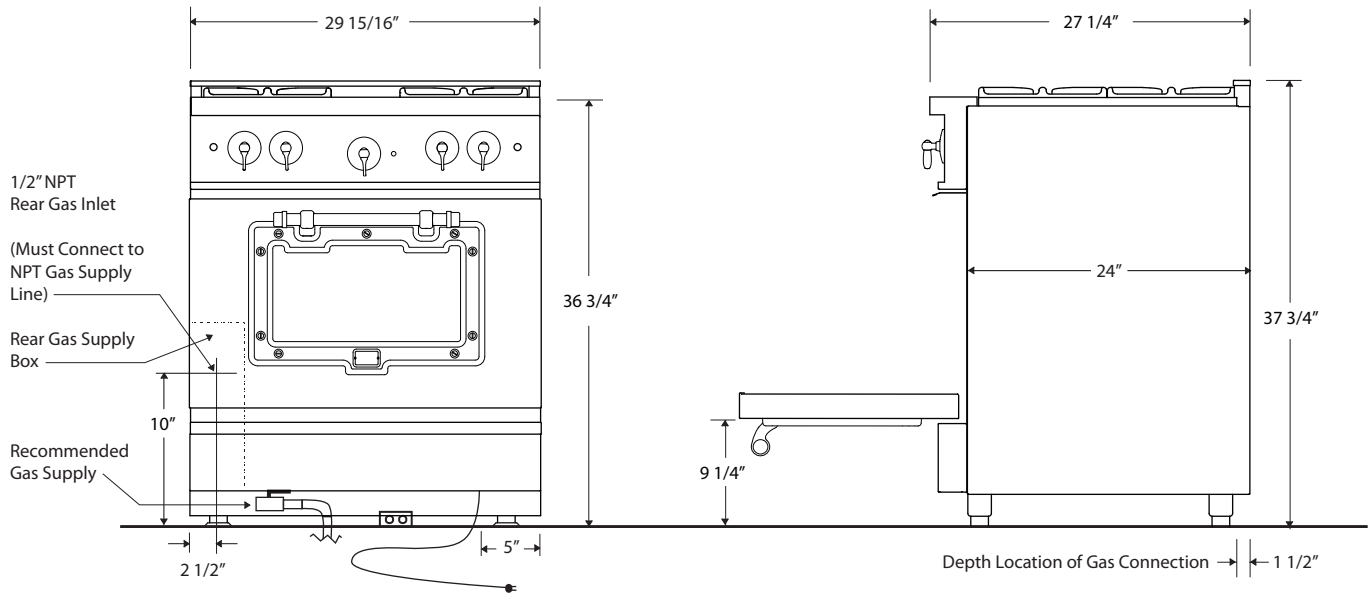

Front Burners	15-18,000 BTU
Back Left Burner (Simmer)	6,000 BTU
Back Right Burner	10,000 BTU
Infrared Broiler Rating	15,000 BTU
Oven Burner Rating	30,000 BTU
Electrical Requirements	120 VAC, 15 Amps,
*(Unit must be on a non-GFI, dedicated outlet)	Single Phase

*Easy to clean Sealed Burner Top
*Automatic electronic ignition and re-ignition system
*24" depth for compatibility with standard kitchen cabinetry
*Convection fan
*Full Extension oven rack
*Heavy-duty, commercial stainless steel construction
*1 year parts and labor warranty

Operating Gas Pressure	NAT: 5.0" WC LP: 10.0" WC
Install Clearance:	0" Side Cabinet 0" Back Wall 6" Side Wall

**OVEN CAPACITY:**  
The cavity design of the oven provides the most precise temperature control, which delivers even heat distribution resulting in versatile performance. It has the largest oven capacity available on a 30" range and will accommodate a full-size commercial 18" x 26" baking sheet.

**INFRARED BROILER:**  
Because of its popularity in the commercial market, the direct-fired ceramic infrared broiler is standard on all residential ranges. The large burner produces 1850 F of intense, searing heat close to the burner, while effecting a gentler broiling for foods placed farther away. The broiler is fully recessed into the oven's top to create maximum cooking space.

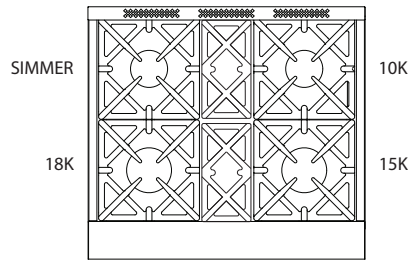

**FULL MOTION GRATES:**  
Bring sauce to a boil while stirring on a front burner, then slide it to the rear to simmer while you saute up front! Our full motion grates allow you to easily reposition pots and pans from front to rear burners without lifting. The grates are also oversized to accommodate the largest stock pots and saute pans.



# 36" CLASSIC RANGE FEATURES AND SPECIFICATIONS

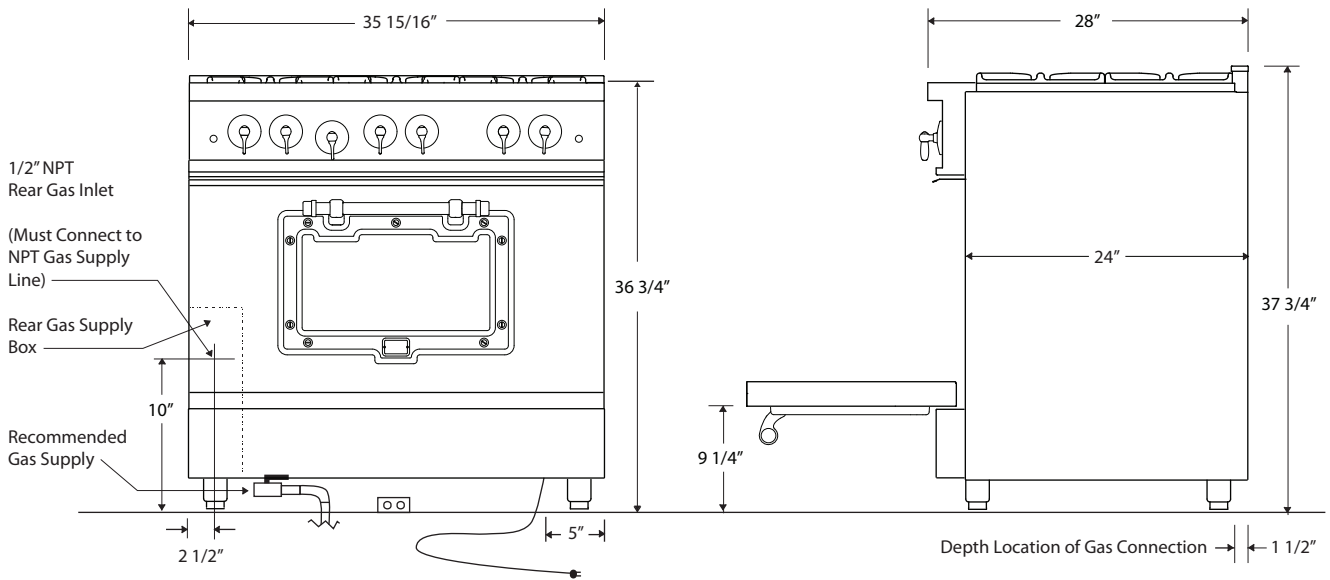

Front Burners	15,000-18,000 BTU	*Easy to clean Sealed Burner Top
Back Left Burner (Simmer)	6,000 BTU	*Automatic electronic ignition and re-ignition system
Back Center / Right Burner	10,000 BTU	*24" depth for compatibility with standard kitchen cabinetry
Infrared Broiler Rating	15,000 BTU	*Convection fan
Oven Burner Rating	30,000 BTU	*Full Extension oven rack
Electrical Requirements	120 VAC, 15 Amps,	*Heavy-duty, commercial stainless steel construction
*(Unit must be on a non-GFI, dedicated outlet)	Single Phase	*1 year parts and labor warranty
Operating Gas Pressure	NAT: 5.0" WC LP: 10.0" WC	OVEN CAPACITY:
Install Clearance:	0" Side Cabinet 0" Back Wall 6" Side Wall	The cavity design of the oven provides the most precise temperature control, which delivers even heat distribution resulting in versatile performance. It has the largest oven capacity available on a 30" range and will accommodate a full-size commercial 18" x 26" baking sheet.

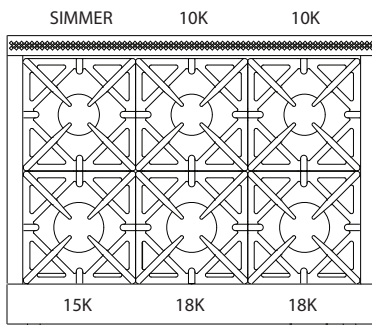

## INFRARED BROILER:

Because of its popularity in the commercial market, the direct-fired ceramic infrared broiler is standard on all residential ranges. The large burner produces 1850 F of intense, searing heat close to the burner, while effecting a gentler broiling for foods placed farther away. The broiler is fully recessed into the oven's top to create maximum cooking space.

## FULL MOTION GRATES:

Bring sauce to a boil while stirring on a front burner, then slide it to the rear to simmer while you saute up front! Our full motion grates allow you to easily reposition pots and pans from front to rear burners without lifting. The grates are also oversized to accommodate the largest stock pots and saute pans.

# 48" CLASSIC RANGE FEATURES AND SPECIFICATIONS

MODEL:  
BCCS48

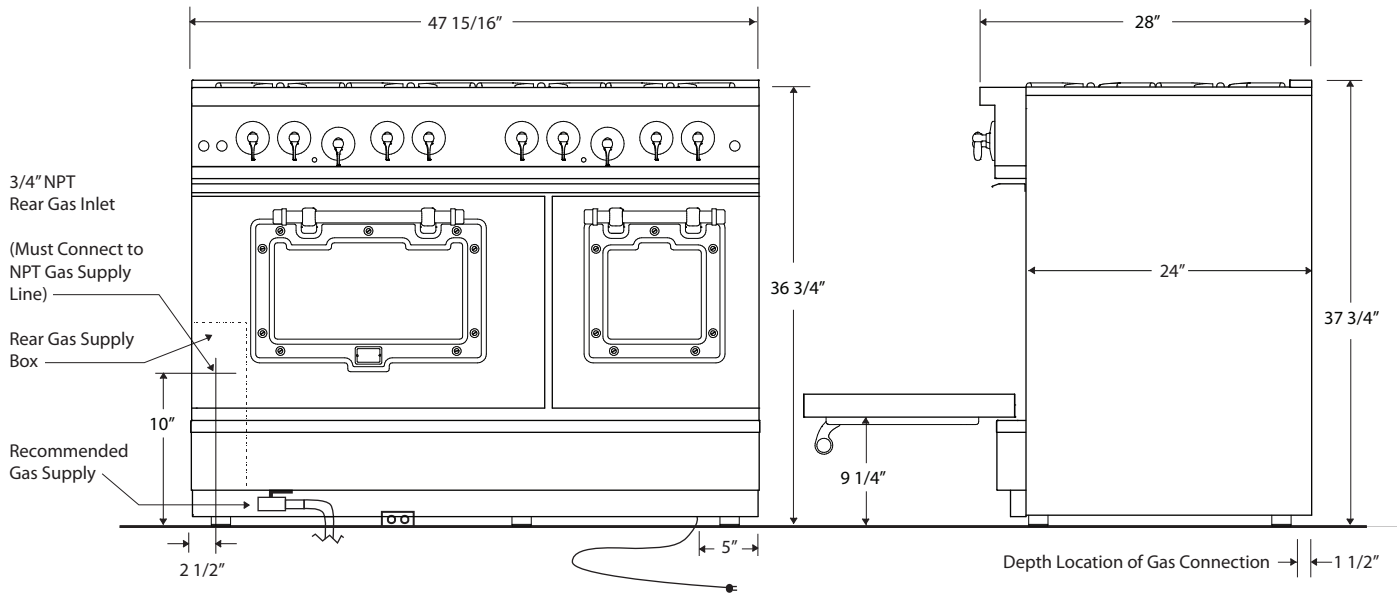

Front Burners	15,000–18,000 BTU	*Easy to clean Sealed Burner Top
Back Left Burner (Simmer)	6,000 BTU	*Automatic electronic ignition and re-ignition system
Back Burners	6,000–10,000 BTU	*24" depth for compatibility with standard kitchen cabinetry
Infrared Broiler Rating	15,000 BTU	*Convection fan
Oven Burner Rating	30,000 BTU	*Full Extension oven rack
Electrical Requirements	120 VAC, 15 Amps,	*Heavy-duty, commercial stainless steel construction
*(Unit must be on a non-GFI, dedicated outlet)	Single Phase	*1 year parts and labor warranty
Operating Gas Pressure	NAT: 5.0" WC LP: 10.0" WC	OVEN CAPACITY:
Install Clearance:	0" Side Cabinet 0" Back Wall 6" Side Wall	The cavity design of the oven provides the most precise temperature control, which delivers even heat distribution resulting in versatile performance. It has the largest oven capacity available on a 48" range and will accommodate a full-size commercial 18" x 26" baking sheet.
		INFRARED BROILER:
		Because of its popularity in the commercial market, the direct-fired ceramic infrared broiler is standard on all residential ranges. The large burner produces 1850 F of intense, searing heat close to the burner, while effecting a gentler broiling for foods placed farther away. The broiler is fully recessed into the oven's top to create maximum cooking space.
		FULL MOTION GRATES:
		Bring sauce to a boil while stirring on a front burner, then slide it to the rear to simmer while you saute up front! Our full motion grates allow you to easily reposition pots and pans from front to rear burners without lifting. The grates are also oversized to accommodate the largest stock pots and saute pans.

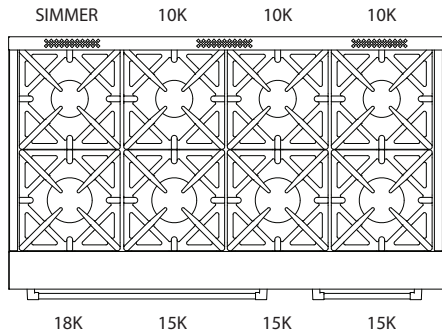

# CLASSIC RANGE HOOD FEATURES AND SPECIFICATIONS

1900 Series Hood	10" Hood	10" Hood—RECIRCULATING
<p>MODELS: (BCH3018) (BCH3618)</p>	<p>MODELS: (BCH3010) (BCH3610)</p>	<p>MODELS: (BCH3010R) (BCH3010R)</p>
<p>Dimensions      18"H x 30" or 36"W x 24"D</p> <p>Vent                External, Reversible top                          or rear exhaust.</p> <p>Blower             600 CFM/ 3-Speed</p> <p>Electrical         120 VAC, 15 Amps</p>	<p>Dimensions      10"H x 30" or 36"W x 24"D</p> <p>Vent                External, Reversible top                          or rear exhaust.</p> <p>Blower             600 CFM/ Variable Speed</p> <p>Electrical         120 VAC, 15 Amps</p>	<p>Dimensions      10"H x 30" or 36"W x 24"D</p> <p>Vent                Recirculating</p> <p>Blower             520 CFM/ Variable Speed</p> <p>Electrical         120 VAC, 15 Amps</p>

**FEATURES:**

Commercial grade 18 gauge 300 stainless steel construction, Welded seamless corners, Dishwasher safe stainless steel baffle filters, Variable or 3-speed blower control, Halogen lamps with dimmer control, Largest filtered capture in the industry

**INSTALL NOTES:**

Allow 30"-36" between stove top and bottom of range hood (or per your local city codes).



TOLL FREE: 1-877-842-3269

EMAIL: info@bigchill.com

WEB: www.bigchill.com

## CLASSIC FEATURES AND SPECIFICATIONS

### 24" CLASSIC DISHWASHER

MODEL:  
DW24-CLA

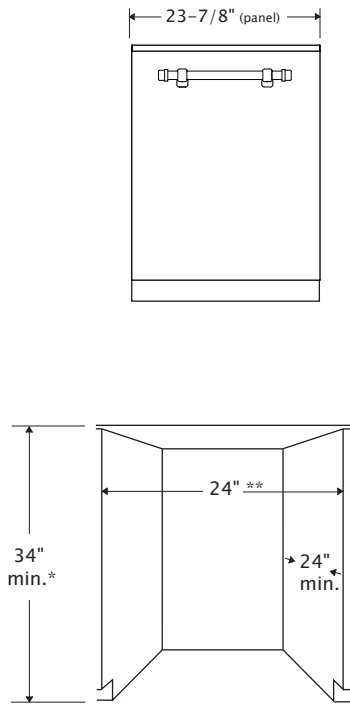

### 36" CLASSIC REFRIGERATOR

MODEL:  
22BF-CLA

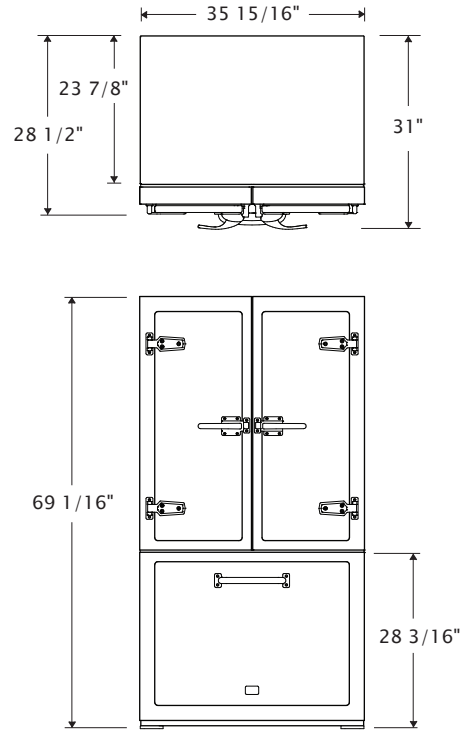

Capacity	14 Place Settings
Cycles	6
Cycles	Tough, Normal, Light, Express Wash, Rinse Only
Cycle Options	6
Energy Guide	270 (kWh/year) (E Star)
Warranty	One Year Parts and Labor
Electrical	15 or 20 Amp, 120 V, 60 Hz, AC only.

**FEATURES:**

Stamped Metal Body, Authentic chrome, brass or satin nickel trim,  
Whisper Quiet® Plus (46 dBA) Sound Reduction, Stainless Steel Interior,  
Hard food disposer, 3 Racks, Energy Star Qualified



\* Measured from the lowest point on the underside of countertop.

\*\* Minimum, measured from narrowest point of opening.

*Big Chill*

Total Capacity	22.3 cu. ft.
Refrigerator Capacity	13.3cu. ft.
Freezer Capacity	6.56 cu. ft.
Clearance: Back	1/2"
Clearance: Side	1/4"
Side Clearance for door to open 90°	4 1/2"
Adjustable Rollers	Standard
Energy Guide (kWh/year)	566 (E Star)
Warranty	One Year Parts and Labor
Electrical	120V, 60Hz, AC only, 15 or 20 amp fused

**FEATURES:**

Stamped Metal Body, Authentic chrome, brass or satin nickel trim, Duo  
cycle cooling, Gallon Door Storage, 2 Half-Width Clear Crisper Drawers,  
Four Half-Width Adjustable Glass Shelves, Internal water dispenser,  
Ice maker, Interior LED lighting, Digital temperature management System,  
Slide-Out Upper Freezer Basket, Glide-Out Freezer Basket with Organizer,  
Energy Star Qualified





ADDRESS: P.O. Box 892, Boulder, CO 80306

TOLL FREE: 1-877-842-3269

FAX: 720-565-0650

EMAIL: info@bigchill.com

WEB: www.bigchill.com

MODEL	DESCRIPTION	RETAIL
-------	-------------	--------

**COOKING / VENTILATION**

BCRI30	30" Retro Electric Induction Range (29 7/8"W x 43 1/2"H x 27 1/2"D)	\$5095
BCS30*	30" All Gas Freestanding Retro Range (29 15/16"W x 43 1/2"H x 27 1/2"D)	\$4595
BCS36*	36" All Gas Freestanding Retro Range (35 15/16"W x 43 1/2"H x 27 1/2"D)	\$5795
BCS30-CLA*	30" All Gas Freestanding Classic: 1900 Series Range (29 15/16"W x 43 1/2"H x 27 1/2"D)	\$4995
BCS36-CLA*	36" All Gas Freestanding Classic: 1900 Series Range (35 15/16"W x 43 1/2"H x 27 1/2"D)	\$5995
BCS48-CLA*	48" All Gas Freestanding Classic: 1900 Series Range (47 15/16"W x 37 2/4"H x 28"D) <small>*Ranges available in Natural Gas (NG) or Propane (LPG).</small>	\$6995
BCH3010	30" Retro Hood (30"W x 10"H x 24"D). 600 CFM blower included.	\$1695
BCH3010R	30" Recirculating Retro Hood (30"W x 10"H x 24"D). 500 CFM blower included.	\$1895
BCH3015	30" Retro Hood (30"W x 15"H x 24"D). 600 CFM blower included.	\$1995
BCH3615	36" Retro Hood (36"W x 15"H x 24"D). 600 CFM blower included.	\$2095
BCH3610	36" Retro Hood (36"W x 10"H x 24"D). 600 CFM blower included.	\$1995
BCH3610R	36" Recirculating Retro Hood (36"W x 10"H x 24"D). 500 CFM blower included.	\$2195
BCH3012	30" Retro Bungalow Hood (30"W x 12"H x 24"D). 600 CFM blower included.	\$2195
BCH3612	36" Retro Bungalow Hood (36"W x 12"H x 24"D). 600 CFM blower included.	\$2295
BCH3018-CLA	30" Classic: 1900 Series Hood (30"W x 18"H x 24"D). 600 CFM blower included.	\$2795
BCH3618-CLA	36" Classic: 1900 Series Hood (36"W x 18"H x 24"D). 600 CFM blower included.	\$3095
BCH3010-CLA	30" Classic Hood (30"W x 10"H x 24"D). 600 CFM blower included.	\$1695
BCH3010R-CLA	30" Recirculating Classic Hood (30"W x 10"H x 24"D). 500 CFM blower included.	\$1795
BCWO30	30" Retro Wall Oven (30"W x 27 1/2"H)	\$3795
30ICR	30" Retro Induction Cooktop	\$2295
MICRO16	1.6 cu.ft. Retro Countertop Microwave (21 3/4"W x 13"-15 3/8"H x 17 1/4"D)	\$595

**REFRIGERATION**

21TF	20.9 cu.ft. Original Retro Top Freezer Refrigerator (33"W x 68 1/2"H x 33 1/2"D)	\$3395
19BF	18.5 cu.ft. Retroopolitan Bottom Freezer Refrigerator (30"W x 66"H x 31"D)	\$3595
14TF	14.4 cu.ft. Studio Retro Top Freezer Refrigerator (28 1/2"W x 65"H x 33 1/4"D)	\$2895
11TF	10.7 cu.ft. Slim Retro Top Freezer (24 3/4" x 65" x 29 1/2"D)	\$2395
22BF-CLA	22.3 cu.ft Classic French Doors Refrigerator (35 15/16"W x 69 1/16"H x 31" D)	\$4795
OPTIONS FOR REFRIGERATORS:		
ICE	Factory Installed Ice Maker	\$195
LEFT HANDLE	Left Handle / Hinge Right (Standard)	FREE
RIGHT HANDLE	Right Handle / Hinge Left	FREE

**DISHWASHING**

DW24	24" Retro Dishwasher, Panel included.	\$1995
DWP24*	Retro Panel Only	\$525
DW24-CLA	24" Classic Dishwasher, Panel included.	\$1995
DWP24-CLA*	Classic Panel Only <small>*Our dishwasher panel is designed to fit KitchenAid Fully Integrated dishwashers. Other brands may fit our panel as well.</small>	\$525

**COLORS**

RETRO COLORS:	White (WT), Black (BK), Beach Blue (BB), Cherry Red (CR), Buttercup Yellow (BY), Jadite Green (JG), Pink Lemonade (PL), Orange (OR) <small>*Note: Retro colors are only free when ordered with Retro products</small>	FREE
CLASSIC COLORS:	White (WT), Matte Black (MB), French Blue (FB), Cabernet (CA), Cream (CM), Stainless Steel (SS) <small>*Note: Classic colors are only free when ordered with Classic products</small>	FREE
CUSTOM RAL COLOR:	Refrigerators / Ranges / Wall Ovens	\$400/ea.
CUSTOM RAL COLOR:	Hoods / Microwaves / Dishwashers	\$150/ea.
PAINTED SIDE PANELS (CLASSIC RANGE ONLY):		
	Unpainted (Stainless Steel):	FREE
	Painted:	\$200



# 30" PRO RANGE FEATURES AND SPECIFICATIONS

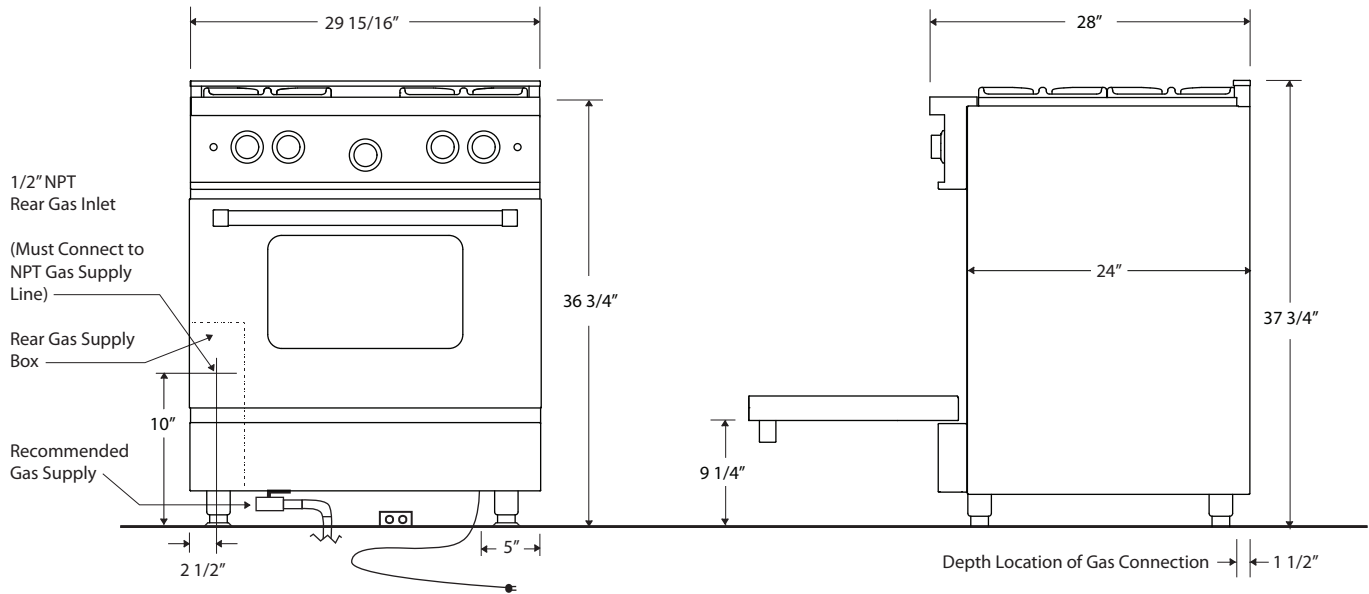

Front Burners	15-18,000 BTU	*Easy to clean Sealed Burner Top
Back Left Burner (Simmer)	6,000 BTU	*Automatic electronic ignition and re-ignition system
Back Right Burner	10,000 BTU	*24" depth for compatibility with standard kitchen cabinetry
Infrared Broiler Rating	15,000 BTU	*Convection fan
Oven Burner Rating	30,000 BTU	*Full Extension oven rack
Electrical Requirements	120 VAC, 15 Amps,	*Heavy-duty, commercial stainless steel construction
*(Unit must be on a non-GFI, dedicated outlet)	Single Phase	*1 year parts and labor warranty
Operating Gas Pressure	NAT: 5.0" WC LP: 10.0" WC	OVEN CAPACITY:
Install Clearance:	0" Side Cabinet 0" Back Wall 6" Side Wall	The cavity design of the oven provides the most precise temperature control, which delivers even heat distribution resulting in versatile performance. It has the largest oven capacity available on a 30" range and will accommodate a full-size commercial 18" x 26" baking sheet.

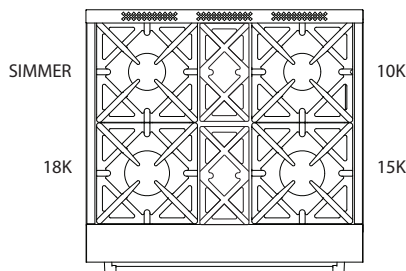

### INFRARED BROILER:

Because of its popularity in the commercial market, the direct-fired ceramic infrared broiler is standard on all residential ranges. The large burner produces 1850 F of intense, searing heat close to the burner, while effecting a gentler broiling for foods placed farther away. The broiler is fully recessed into the oven's top to create maximum cooking space.

### FULL MOTION GRATES:

Bring sauce to a boil while stirring on a front burner, then slide it to the rear to simmer while you saute up front! Our full motion grates allow you to easily reposition pots and pans from front to rear burners without lifting. The grates are also oversized to accommodate the largest stock pots and saute pans.



# 36" PRO RANGE FEATURES AND SPECIFICATIONS

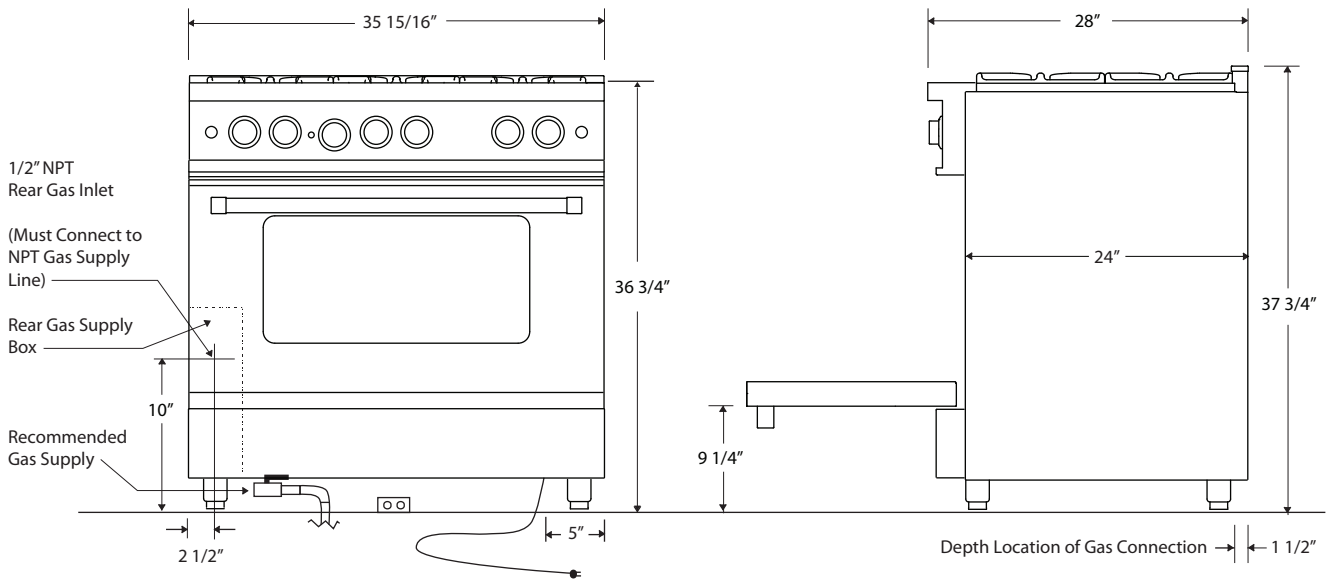

Front Burners	15,000-18,000 BTU	*Easy to clean Sealed Burner Top
Back Left Burner (Simmer)	6,000 BTU	*Automatic electronic ignition and re-ignition system
Back Center / Right Burner	10,000 BTU	*24" depth for compatibility with standard kitchen cabinetry
Infrared Broiler Rating	15,000 BTU	*Convection fan
Oven Burner Rating	30,000 BTU	*Full Extension oven rack
Electrical Requirements	120 VAC, 15 Amps,	*Heavy-duty, commercial stainless steel construction
*(Unit must be on a non-GFI, dedicated outlet)	Single Phase	*1 year parts and labor warranty
Operating Gas Pressure	NAT: 5.0" WC LP: 10.0" WC	OVEN CAPACITY:
Install Clearance:	0" Side Cabinet 0" Back Wall 6" Side Wall	The cavity design of the oven provides the most precise temperature control, which delivers even heat distribution resulting in versatile performance. It has the largest oven capacity available on a 30" range and will accommodate a full-size commercial 18" x 26" baking sheet.

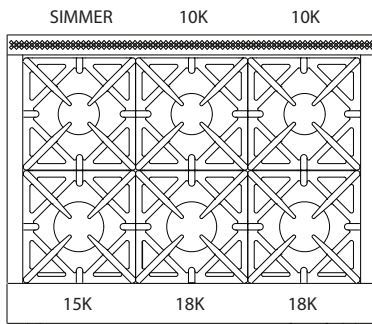

## INFRARED BROILER:

Because of its popularity in the commercial market, the direct-fired ceramic infrared broiler is standard on all residential ranges. The large burner produces 1850 F of intense, searing heat close to the burner, while effecting a gentler broiling for foods placed farther away. The broiler is fully recessed into the oven's top to create maximum cooking space.

## FULL MOTION GRATES:

Bring sauce to a boil while stirring on a front burner, then slide it to the rear to simmer while you saute up front! Our full motion grates allow you to easily reposition pots and pans from front to rear burners without lifting. The grates are also oversized to accommodate the largest stock pots and saute pans.

# 48" PRO RANGE FEATURES AND SPECIFICATIONS

MODEL:  
BCPRO48

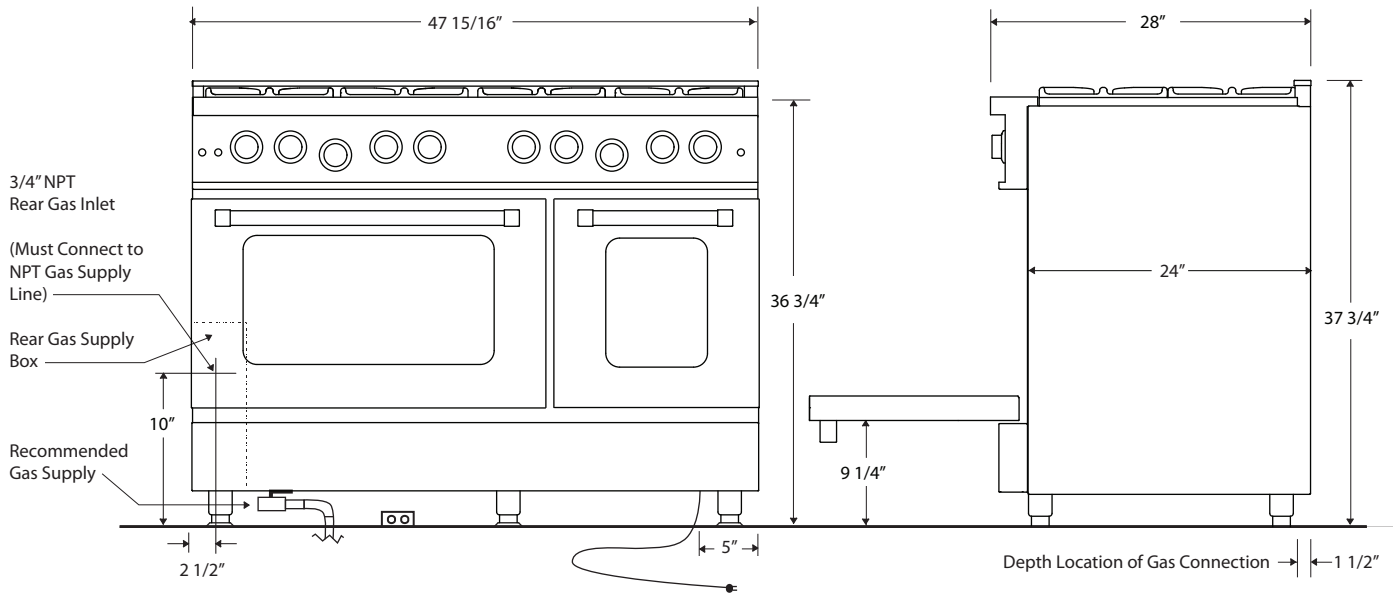

Front Burners	15,000-18,000 BTU	*Easy to clean Sealed Burner Top
Back Left Burner (Simmer)	6,000 BTU	*Automatic electronic ignition and re-ignition system
Back Burners	6,000-10,000 BTU	*24" depth for compatibility with standard kitchen cabinetry
Infrared Broiler Rating	15,000 BTU	*Convection fan
Oven Burner Rating	30,000 BTU	*Full Extension oven rack
Electrical Requirements	120 VAC, 15 Amps,	*Heavy-duty, commercial stainless steel construction
*(Unit must be on a non-GFI, dedicated outlet)	Single Phase	*1 year parts and labor warranty
Operating Gas Pressure	NAT: 5.0" WC LP: 10.0" WC	OVEN CAPACITY:
Install Clearance:	0" Side Cabinet 0" Back Wall 6" Side Wall	The cavity design of the oven provides the most precise temperature control, which delivers even heat distribution resulting in versatile performance. It has the largest oven capacity available on a 48" range and will accommodate a full-size commercial 18" x 26" baking sheet.

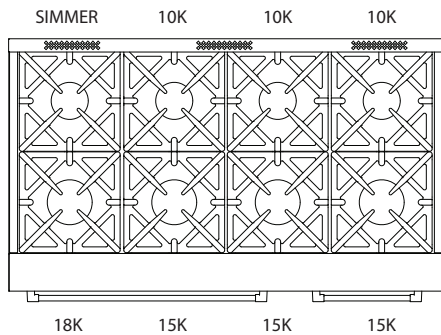

## INFRARED BROILER:

Because of its popularity in the commercial market, the direct-fired ceramic infrared broiler is standard on all residential ranges. The large burner produces 1850 F of intense, searing heat close to the burner, while effecting a gentler broiling for foods placed farther away. The broiler is fully recessed into the oven's top to create maximum cooking space.

## FULL MOTION GRATES:

Bring sauce to a boil while stirring on a front burner, then slide it to the rear to simmer while you saute up front! Our full motion grates allow you to easily reposition pots and pans from front to rear burners without lifting. The grates are also oversized to accommodate the largest stock pots and saute pans.

## PRO FEATURES AND SPECIFICATIONS

### 24" PRO DISHWASHER

MODEL:  
DW24-PRO

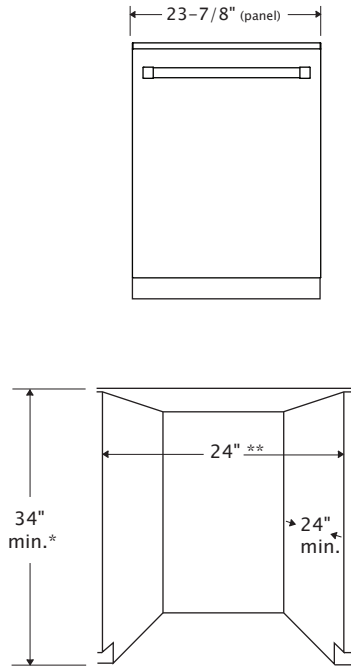

### 30" PRO Refrigerator

MODEL:  
19BF-PRO

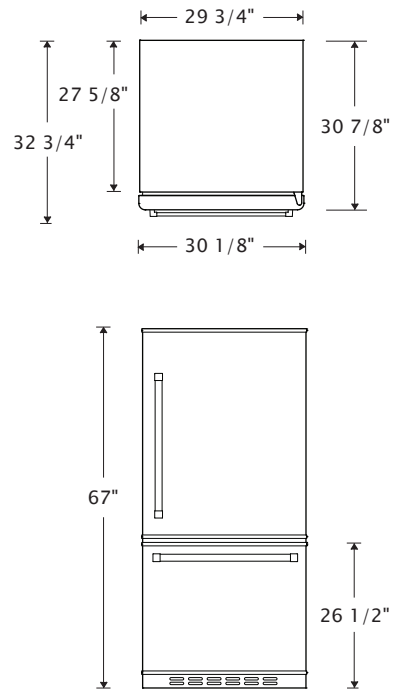

Capacity	14 Place Settings
Cycles	6
Cycles	Tough, Normal, Light, Express Wash, Rinse Only
Cycle Options	6
Energy Guide	270 (kWh/year) (E Star)
Warranty	One Year Parts and Labor
Electrical	15 or 20 Amp, 120 V, 60 Hz, AC only.

**FEATURES:**

Stamped Metal Body, Authentic chrome or stainless trim, Whisper Quiet® Plus (46 dBA) Sound Reduction, Stainless Steel Interior, Hard food disposer, 3 Racks, Energy Star Qualified

\* Measured from the lowest point on the underside of countertop.

\*\* Minimum, measured from narrowest point of opening.



Total Capacity	18.5 cu. ft.
Refrigerator Capacity	12.9 cu. ft.
Freezer Capacity	5.6 cu. ft.
Clearance: Back	1/2"
Clearance: Side	1/4"
Side Clearance for door to open 90°	3 1/2"
Adjustable Rollers	Standard
Energy Guide (kWh/year)	521
Electrical	115V, 60Hz, AC only, 15 or 20 amp fused

**FEATURES:**

Stamped Metal Body, Chrome Trim, Gallon Door Storage, 2 Half-Width Clear Crisper Drawers, Four Half-Width Adjustable Glass Shelves, Temperature Management System, Slide-Out Upper Freezer Basket, Glide-Out Freezer Basket with Organizer, Optional Ice Maker, Available Left Hand Hinge, One Year Parts and Labor Warranty

# PRO HOOD FEATURES AND SPECIFICATIONS

## 10" PRO Hood

MODEL:  
BCH3010-PRO (30")  
BCH3610-PRO (36")

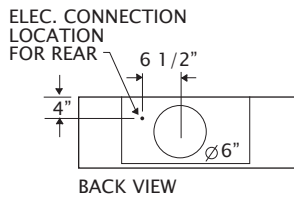
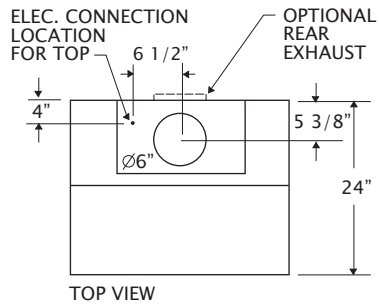
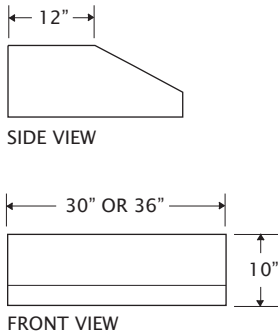

Dimensions	10"H x 30" or 36"W x 24"D
Vent	External, Reversible top or rear exhaust.
Blower	600 CFM
Electrical	120 VAC, 15 Amps

## 10" PRO Hood RECIRCULATING

MODEL:  
BCH3010R-PRO (30")  
BCH3610R-PRO (36")

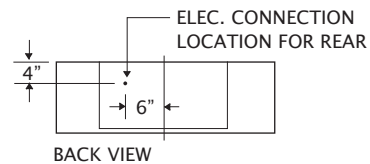
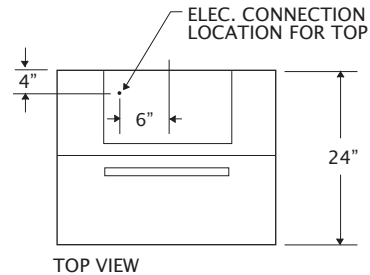
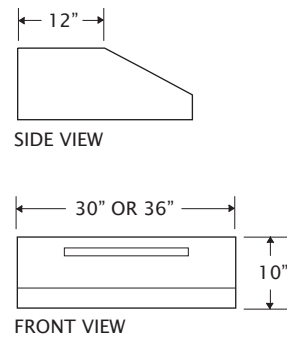

Dimensions	10"H x 30" or 36"W x 24"D
Vent	Recirculating
Blower	520 CFM
Electrical	120 V, 15 Amps

### FEATURES:

Commercial grade 18 gauge 300 stainless steel construction, Welded seamless corners, Dishwasher safe stainless steel baffle filters, Variable blower control, Halogen lamps with dimmer control, Largest filtered capture in the industry

INSTALL NOTES: Allow 30"-36" between stove top and bottom of range hood (or per your local city codes).



# PRO HOOD FEATURES AND SPECIFICATIONS

## 18" x 48" PRO Hood

MODEL:  
BC-PRO48HOOD

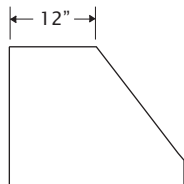

SIDE VIEW

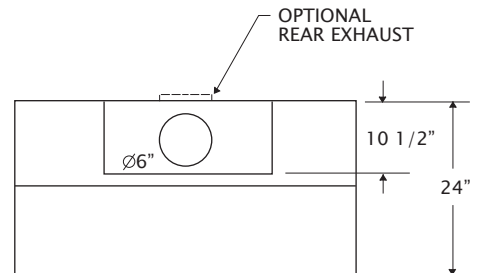

TOP VIEW

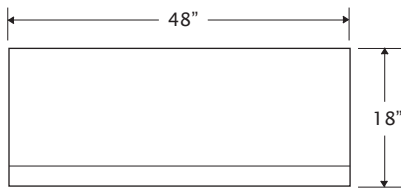

FRONT VIEW

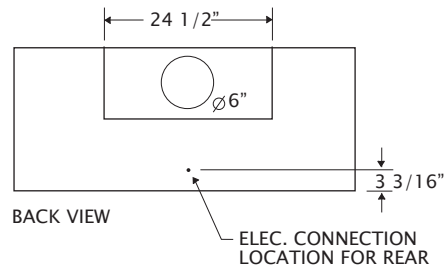

BACK VIEW

Dimensions	18"H x 48"W x 24"D
Vent	External, Reversible top or rear exhaust.
Blower	600 CFM
Electrical	120 VAC, 15 Amps

### FEATURES:

Commercial grade 16 gauge 300 stainless steel construction, Welded seamless corners, Dishwasher safe stainless steel baffle filters, Variable blower control, Halogen lamps with dimmer control, Largest filtered capture in the industry

INSTALL NOTES: Allow 30"-36" between stove top and bottom of range hood (or per your local city codes).





TOLL FREE: 1-877-842-3269

EMAIL: info@bigchill.com

WEB: www.bigchill.com

MODEL	DESCRIPTION	RETAIL
-------	-------------	--------

### RANGES / HOODS

BCS30-PRO*	30" All Gas Pro-Style Freestanding Range (29 7/8"W x 37 3/4"H x 28"D)	\$3495
BCS36-PRO*	36" All Gas Pro-Style Freestanding Range (35 15/16"W x 37 3/4"H x 28"D)	\$3995
BCS48-PRO*	48" All Gas Pro-Style Freestanding Range (47 15/16"W x 37 3/4"H x 28"D)	\$5595
6" Backguard	30" / 36" / 48" backguard (6"H)	\$360

\*Ranges available in Natural Gas (NG) or Propane (LPG).

BCH3010-PRO	30" Pro-Style Hood (30"W x 10"H x 24"D). 600 CFM blower included.	\$1595
BCH3010R-PRO	30" Recirculating Pro-Style Hood (30"W x 10"H x 24"D). 500 CFM blower included.	\$1895
BCH3610-PRO	36" Pro-Style Hood (36"W x 10"H x 24"D). 600 CFM blower included	\$1995
BCH3610R-PRO	36" Recirculating Pro-Style Hood (36"W x 10"H x 24"D). 500 CFM blower included.	\$2095
BC-PRO48HOOD	48" Pro-Style Hood (48"W x 18"H x 24"D). 600 CFM blower included	\$2895

#### COLOR OPTIONS FOR RANGES / HOODS:

White (WT), Matte Black (MB), French Blue (FB), Cherry Red (CR), Sunflower Yellow (SY), Basil Green (BG), Orange (OR), Slate (SL), Stainless Steel (SS) \$0

Custom RAL Color (CC) - Ranges \$400  
Custom RAL Color (CC) - Hoods \$150

### REFRIGERATORS

19BF-PRO	18.5 cu.ft. Bottom Freezer Refrigerator (30"W x 66"H x 31"D)	\$3595
----------	--	--------

#### COLOR OPTIONS FOR REFRIGERATORS:

White (WT), Matte Black (MB), French Blue (FB), Cherry Red (CR), Sunflower Yellow (SY), Basil Green (BG), Orange (OR), Slate (SL) \$0

Custom RAL Color (CC) \$400

#### OPTIONS FOR REFRIGERATORS:

ICE	Factory Installed Ice Maker	\$195
LEFT HANDLE	Left Handle / Hinge Right (Standard)	\$0
RIGHT HANDLE	Right Handle / Hinge Left	\$0

### DISHWASHERS

DW24-PRO	24" Dishwasher, Stainless Steel Tub, Panel included.	\$1995
DWP24-PRO*	Panel Only	\$525

\*Our dishwasher panel is designed to fit KitchenAid Fully Integrated dishwashers. Other brands may fit our panel as well.

#### COLOR OPTIONS FOR DISHWASHERS:

White (WT), Matte Black (MB), French Blue (FB), Cherry Red (CR), Sunflower Yellow (SY), Basil Green (BG), Orange (OR), Slate (SL), Stainless Steel (SS) \$0

Custom RAL Color (CC) \$150