

Operation, Maintenance and Installation Manual

# VG 411

Gas Cooker



**GAGGENAU**

<b>1. Important Notes</b>	<b>Page 3-4</b>
For Your Safety	Page 3
Operating for the First Time	Page 3
About Use	Page 4
<b>2. Features</b>	<b>Page 5</b>
Features of the Appliance	Page 5
Control Knob	Page 5
Burner Parts	Page 5
<b>3. Operating Principle</b>	<b>Page 6</b>
<b>4. Operation</b>	<b>Page 7</b>
<b>5. Settings Table</b>	<b>Page 8</b>
<b>6. Cookware Recommendations</b>	<b>Page 9</b>
<b>7. Wok Cookware Recommendations</b>	<b>Page 10</b>
<b>8. Cleaning and Care</b>	<b>Page 11-12</b>
<b>9. Maintenance</b>	<b>Page 13</b>
<b>10. Trouble Shooting</b>	<b>Page 14</b>
<b>11. Technical Data / Nozzle Table</b>	<b>Page 15</b>
<b>12. Installation Instructions</b>	<b>Page 16-23</b>
Important Notes on Installation	Page 16
Connecting the Appliance	Page 17
Preparing the Cabinet	Page 18
Installing the Cooker	Page 19
Installing the Spindle	Page 20-21
Nozzle Replacement	Page 22-23

**Congratulations on buying your new  
“Vario” appliance.**

Before switching your appliance on for the first time, we would like you to familiarize yourself with your new appliance. In this manual you will find important notes on safety and operation. These will serve to ensure your personal safety and the lasting value of your appliance. Keep the instruction manual near your appliance for further reference.

You will find notes on Page 3 that you ought to observe before operating the appliance for the first time.

The chapters entitled “Features” and “Operation” tell you all about what your appliance can do and how you operate it.

The chapter entitled “Cleaning and Care” gives tips on how to keep your appliance looking good.

**And now we wish you lots of fun cooking.**

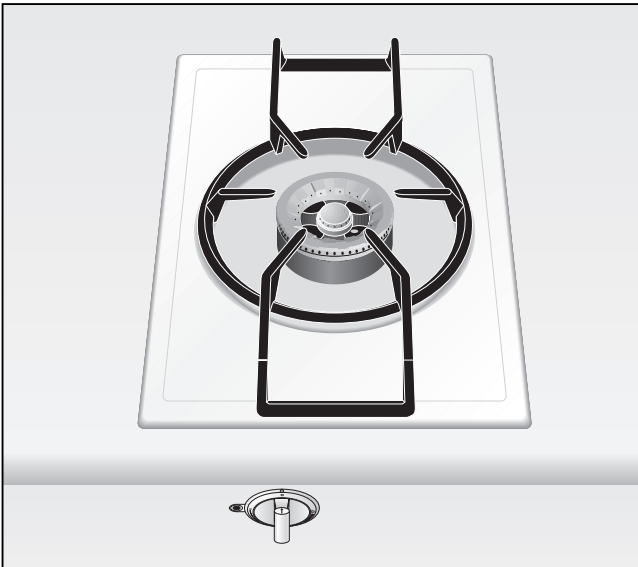

# 1. Important Notes

## For Your Safety

You must not operate the appliance if it is damaged.

When connecting electrical appliances in the proximity of the appliance, make sure that connecting leads do not come into contact with hot cooking surfaces!

As the user, you yourself are responsible for maintenance and proper use in the household.

Only ever operate the appliance under supervision.

Do not operate the appliance without pots and pans placed on it. Make sure that all the burner parts are correctly fitted.

**Caution:** The appliance heats up during operation. Keep children away.

Do not clean the appliance with a steam cleaning apparatus or with water pressure - **risk of short-circuits!**

Isolate the appliance from the mains during every maintenance operation. To do this, remove the mains plug or switch off the corresponding household fuse. Close the gas supply.

Repairs must be carried out by authorised specialists, thus ensuring electrical safety.

No warranty claims can be lodged for any damage resulting from failure to observe these instructions.

**Observe caution** with oils and fats. They may overheat and burn easily. Foodstuffs that are prepared in fat and oil must only be prepared under constant supervision!

**Technical modifications reserved.**

## Operating for the First Time

Remove the packaging from the appliance and dispose of it according to local regulations. Be careful to remove all accessories from the packaging. Keep packaging elements and plastic bags away from children.



This appliance is labelled in accordance with the European Directive 2002/96/EG concerning used electrical and electronic appliances (waste electrical and electronic equipment - WEEE). The guideline determines the framework for the return and recycling of used appliances as applicable.

Check the appliance for transport damage before installing it.

The appliance must be installed and connected by an authorised specialist before operation. The installation must conform with all current regulations of the gas supply companies and the regional construction regulations.

Turn the control knob to the OFF position before connecting the appliance to the power supply.

The serial number of the appliance can be found on the quality control slip which is included with these instructions. This quality control slip should be kept, for guarantee reasons, together with your operating and assembly instructions.

Read through these instructions attentively before operating your appliance for the first time.

Thoroughly clean the appliance and accessories before using them for the first time. This will eliminate any 'newness' smells and soiling (see chapter "Cleaning and Care").

---

## About Use

The appliance is intended solely for use in the household and must not be put to any other uses.

Use the appliance to prepare meals only. It must not be used to heat up the room in which it is installed.!

Use of a gas cooker **generates heat and humidity** in the room where it is installed. This is why attention must be paid to good kitchen ventilation. The natural **ventilation openings** must be kept unobstructed. Prolonged use of the appliance with several or all rings may call for additional ventilation such as opening a window or a door, or stronger air extraction by an extractor hood.

**To guarantee good combustion, the room in which the appliance is installed must have a minimum volume of 20 m<sup>3</sup> and must possess a door that opens outdoors or a window that can be opened.**

Keep the ventilation openings at the back of the appliance free at all times.

**Only use the burner after placing a pot or pan on it. Do not heat up any empty pots or pans;** this may result in a build-up of heat. Use pots and pans with thicker bottoms because heat distribution is particularly improved in the low setting. Using pots and pans which are adapted to the burner size increases the efficiency of the heat from the gas flame, thereby reducing power costs.

It is not permitted to use grill stones because the resulting heat build-up may damage the appliance.

Pots with a diameter of less than **160 mm** or more than **320 mm** should not be used. When using large pots, pay attention to keeping to a minimum distance of **50 mm** between the cooking vessel and combustible surroundings.

Switch the burner to the low setting whenever you remove pots or pans briefly. In this way, you reduce the risk of burns when working next to naked flames; you also save gas and reduce pollution.

Whenever the gas hob is fitted under an extractor hood, always cover the ring with a pot or pan. Otherwise, parts of the extractor hood may become damaged by the extreme heat development or grease residues in the filter may ignite.

**Ensure an adequate supply of air when using an extractor hood operating in the extraction mode**

The appliance cannot be used during a **power failure**.

In the event of malfunctions, please inform your specialist dealer or your nearest Gaggenau after-sales service.

## 2. Features

### Features of the Appliance

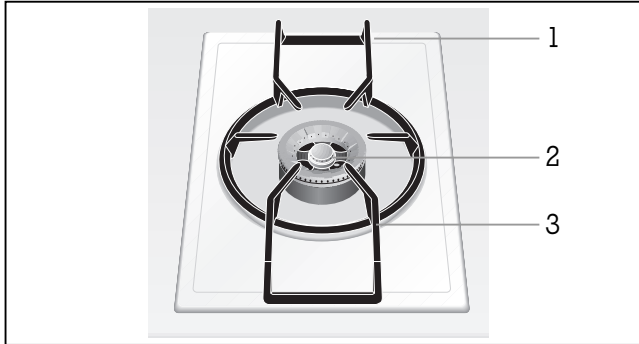



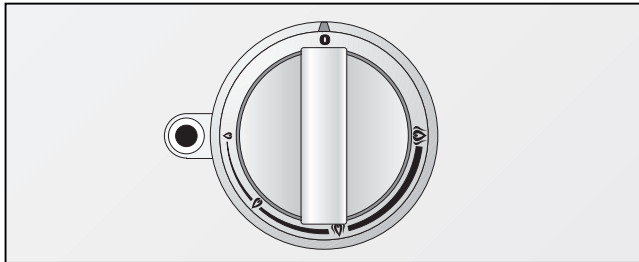

- 1** Ventilation openings
- 2** Large (Wok) burner 5 kW
- 3** Pot grid

### Control Knob



Flame setting:

- 0** OFF
-  High setting of outer and inner flame ring
-  Low setting of outer flame ring  
High setting of inner flame ring
-  Outer flame ring off  
High setting of inner flame ring
-  Outer flame ring off  
Low setting of inner flame ring

### Burner Parts

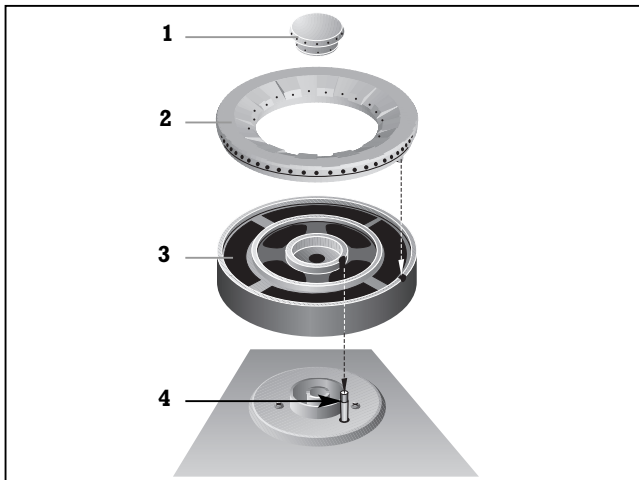

- 1** Burner head cover
- 2** Burner ring
- 3** Burner head
- 4** Electrode for automatic ignition,  
flame detection and flame control

You can order the following special accessory:

- VV 400-000** Connecting trim
- SV 401-090** Spindle extension up to 140 mm
- SV 401-205** Spindle extension up to 300 mm
- VD 400-000** Appliance cover (the pot grid must be removed in order to close the appliance cover)

### 3. Operating Principle

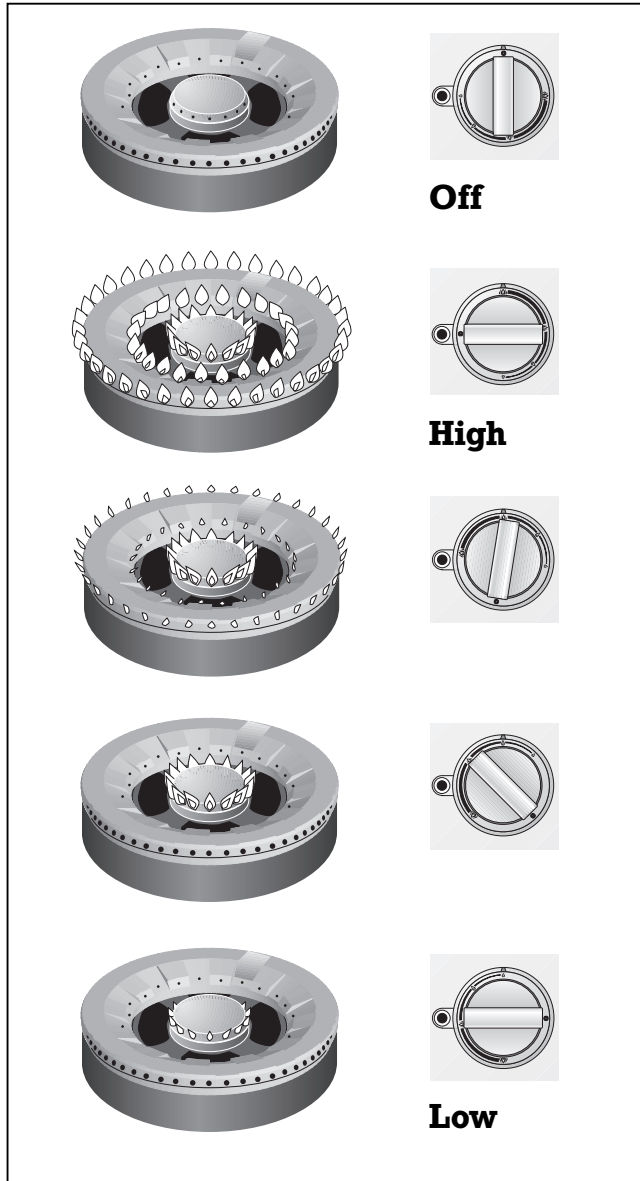

The appliance features one-hand operation, flame detection and automatic re-ignition. The ignition is activated when the control knob is turned.

Should the flame go out during operation, the appliance will automatically re-ignite the burner.

During a disturbance, the appliance will cut off the gas supply as a safety measure, to prevent unburned gas escaping.

The flame setting is infinitely variable between high and low.

The total rated thermal load amounts to:  
5.0 kW referred to  $H_S^*$  (gross calorific value)  
4.5 kW referred to  $H_i$  (calorific value)

The specified rated load is defined by installation of the fixed nozzles.

The gas hob is converted to a different gas type by nozzle replacement (full and low-burning nozzles) (see nozzle table on page 15).

## 4. Operation

Only light the burner if all burner parts are dry, and assembled correctly. Otherwise, malfunctions may occur or the appliance may switch off.

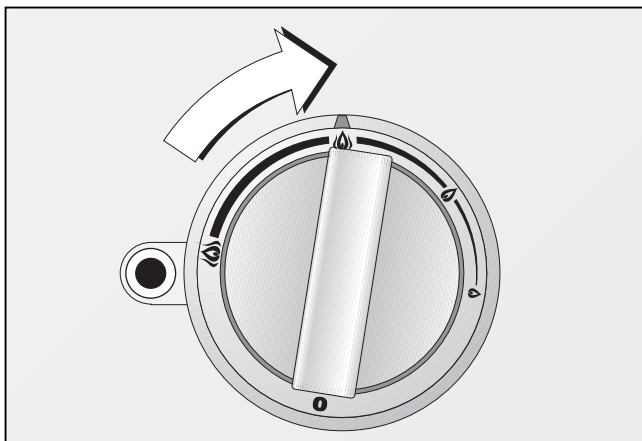
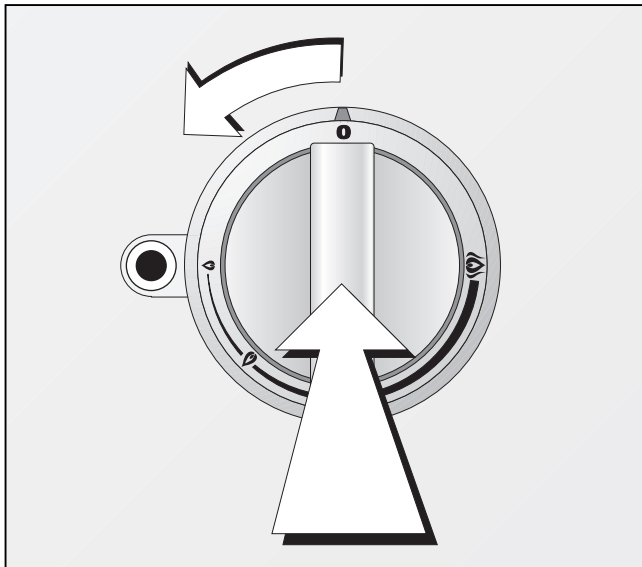

### Switching on

- Place a suitable pot or a pan on the cooking position.
- Press down the control knob and turn it to the required position between the 🔥 and 🔥 symbols. The burner ignites automatically.
- When using large pots or pans you should ignite the burner in the low position.
- Every time the gas hob is switched on, the electronics run an auto test. The electrode fires and the burner ignites after a few seconds.
- When being switched on, a short sound may be heard when the electronic of the gas hob opens the gas supply valve. This is a normal condition.

The flame size can be set continuously between full and low by slowly turning the control knob.







Should the flame go out during operation (e.g. because of a draught), the appliance will automatically re-ignite the burner.

Should the re-ignition be unsuccessful (e.g. burner is soiled by spilled over food or liquid), the gas supply is switched off automatically and a signal is sounded. Turn the control knob to the OFF position. After the appliance has cooled down sufficiently, check if all the burner parts have been assembled correctly. Check if the burner or the electrode have been soiled.

### Switching off

Fully turn the control knob to the OFF position. The electronics of the appliance switch the gas supply off.

## 5. Settings Table

<b>Cooking level</b>	<b>Cooking method</b>	<b>Examples</b>
High 	Boiling Searing Heating Boiling Blanching	Water Meat Fat, liquids Soup, sauce Vegetables
From  to 	Roasting Browning Roasting Baking Boiling in open pot Simmering in open pot	Meat, fish, potatoes Flour, onions Almonds, breadcrumbs Pancakes, egg dishes Liquids Dumplings, sausages, soup garnish, meat stock, poached eggs
From  to 	Simmering Boiling with closed lid Steaming Stewing Braising	Sweet sauces Pasta, soup, sauces Vegetables, potatoes, fish Vegetables, fruit, fish Goulash, rolled beef steaks, roasts, vegetables
Low 	Thawing Slow cooking Reheating	Frozen foods Rice, pulses Soup, casserole, vegetables in a sauce

Switch to the high setting in order to reach the required temperature quickly. Then switch back to a lower setting.

The values given above must be looked upon as recommended values. The heat required depends not only on the type and condition of the food, but also the size and contents of the pot.

Due to the high performance of the cooktop, fat and oil will heat up quickly. Never leave the cooktop unattended, fat can ignite, food can burn.

## 6. Cookware Recommendations

<b>VG 411</b>	<b>Recommended pot diameter</b>	<b>Minimum pot diameter</b>
Wok Burner	240 - 320 mm	160 mm

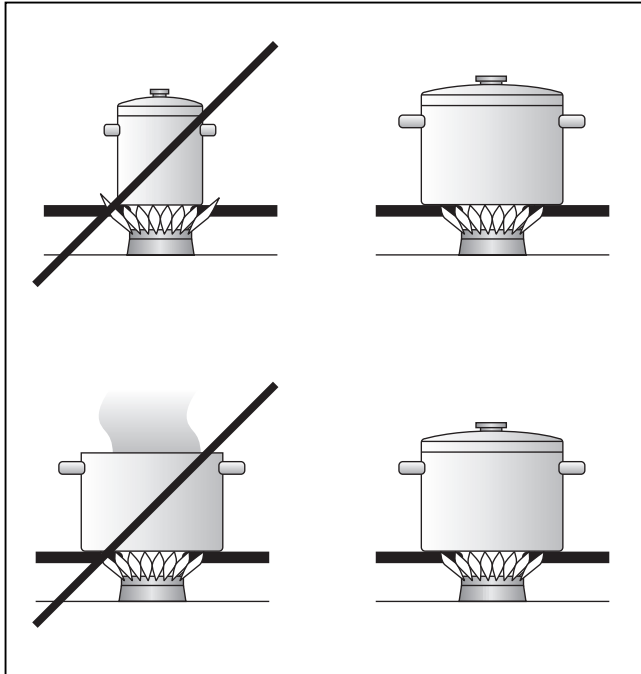

Pots with a diameter of less than **160 mm** or more than **320 mm** should not be used. When using large pots, pay attention to keeping to a minimum distance of **50 mm** between the cooking vessel and combustible surroundings.

When buying pots, pay attention to the fact that the manufacturer frequently specifies the top pot diameter, which is generally larger than the diameter of the base.

Observe the manufacturer's specifications! Use cooking utensils that the manufacturer states as being "suitable for gas". Use pots with heat resistant handles.

Use pots and pans with a thick base, because heat distribution is particularly improved in the low setting. Using the correct size of pots and pans for the burner ensures improved cooking performance and energy efficiency.

To ensure an even distribution of heat, center the pot above the burner. The flames should be covered by the pot base.

Place the pot or pan securely and level on the pot grid. Turn the pan handle to the side, it should not point to the front.

Placing a fitting lid on the pot will shorten cooking times. Through a glass lid you can watch the cooking progress without having to take the lid off.

## 7. Wok Cookware Recommendations

---

### **The Wok and Accessories**

(not included in the scope of delivery)

- The round-bottom wok is the ideal wok for your gas cooker.
- The wok looks like a hollow hemisphere with a long handle or wooden handle. It has a rounded base and slanted sides. The thin steel passes the heat swiftly to the inside, but soon cools down again as soon as the flame is set to a lower setting. Therefore, ingredients cannot overcook.
- The diameter is between 35 - 40 cm for 4 persons.
- Make sure that a wok with a rounded base is positioned safely on the pot grid.
- Woks may consist of various materials. Cast-iron woks are more stable and keep the heat longer.
- They have a round, high cover. Therefore, they are also capable of steaming and stewing.
- The semicircular grid is hooked in on the edge of the wok. On it, you can steam ingredients, you can allow deep fried foods to drip or you can keep browned foods warm.
- Use the chan (rounded spatula) or a long handled, wooden spatula.
- Use a ladle to remove foods.
- Use the strainer to lift deep fried foods from the fat or large pieces out of a sauce.
- You can use bamboo baskets for steaming.

### **Cooking in the Wok**

You can fry, steam, deep fry, stew and cook normally.

Stir frying is the special cooking method for the wok. Ingredients cut into small pieces are cooked as briefly as possible under strong heat and constant stirring. In the large, round pan everything can be stirred and turned faster and with greater ease than in a conventional frying pan. Thanks to stirring, ingredients do not burn onto the pan. Surplus oil drains off towards the middle. In next to no time, you obtain delicious roasted foods, the pores in meat close and fish becomes nice and juicy. Vegetables stay crispy, and aromas and healthy vitamins are retained.

Important: the cooking time is so short that all ingredients should be ready for cooking before you begin. The correct sequence is also important. First place the ingredients with the longest cooking time in the wok. For example, these are hard-fibred vegetables such as carrots. Soft vegetables such as mushrooms or sprouts are added later.

#### **Proceed as follows:**

- Pour sufficient oil into the wok to coat the surface. We advise you to use peanut or or soya oil.
- Heat up the oil to just before the smoking point; only then begin with stir frying.
- Cut the food into pieces of equal size, but not too small, thus making sure they will not burn.
- If you are cooking larger quantities, work with portions as otherwise not all of the food will reach the hot base of the wok.
- Meals that are ready can be kept warm on a minimal flame. Clean the wok after every use and rub its inside with oil. This will prevent rusting.

## 8. Cleaning and Care

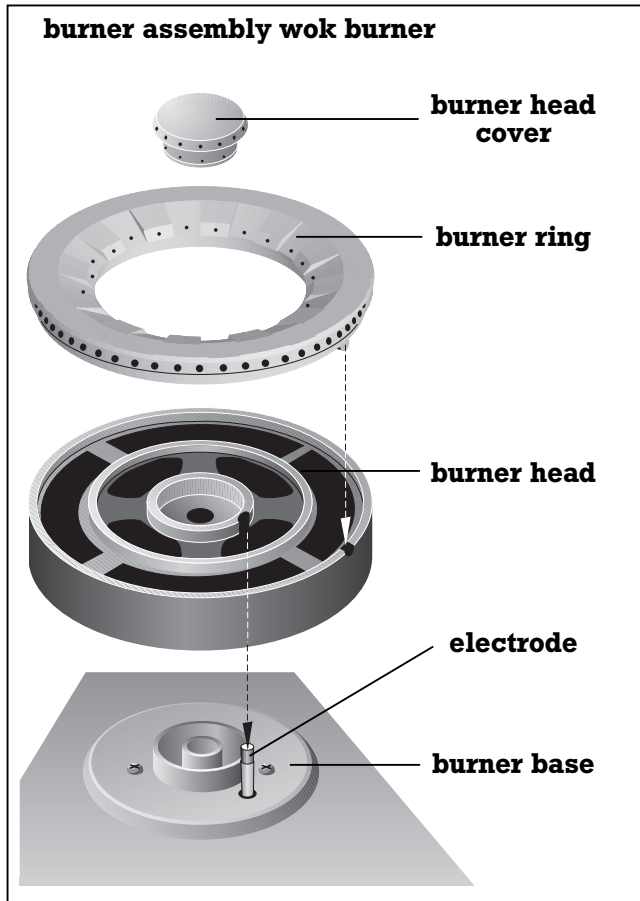

**Note:** to avoid jeopardising the electrical safety of the appliance, do not use high-pressure or steam jet cleaning devices – risk of short circuits!

**Caution, risk of burns! Before cleaning, please wait until the cooktop has cooled to hand-warm. Never switch on the cooktop while cleaning.**

Keep the **ventilation openings** on the rear of the appliance clean. Do not block the ventilation openings.

The burner (burner head cover and burner ring) will change the color during operation and become darker. This change in color will not influence the use-value.

Please thoroughly clean the appliance before operating it for the first time and after every use.

Do not use scouring agents, abrasives or chemically aggressive cleaners (for example oven cleaner)!

Do not use any nitro polishing agents for cleaning! Do not use any abrasive sponges either.

**Before cleaning, please wait until the cooktop has cooled to hand-warm.**

- First lift the **pot grid** with both hands (be careful not to scratch the base).
- Remove the **burner head cover**, the **burner ring** and the **burner head**.
- **Important!** Only clean the burner parts when cold!
- Soak **burnt-in remainders** in a little water and detergent. This loosens even the most stubborn of soiling. Do not use any abrasive agents and abrasive sponges.
- Only use very little water to clean your cooktop. Be careful that no water enters the burner base.
- As the result of heat development, slight discoloration can appear on the stainless steel surface. **Do not attempt to scrape away such discoloration.** This damages the surface. Distribute stainless steel care agents uniformly and thinly on the hob. This will ensure an even surface and will keep your hob in a good condition for a long period of time.

• Make sure the burner parts are dry before assembly. Only operate the appliance with all parts dry. Damp burner parts will cause malfunctions when igniting or unstable flames.

• When assembling the burner parts, make sure that the burner ring and burner head are placed in such a way that the locking lugs fit in the corresponding recesses.

Part / Material	Suggested Cleaning Procedure	Important Reminders
Pot Grid (enamel on cast iron)	Take pot grids off for cleaning. Soak in sink. Clean with detergent and brush.	Do not clean in a dishwasher. Soak burnt-in remainders in sink. Abrasive cleaners, used too vigorously or too often can eventually mar the enamel.
Burner Head Cover, Burner Ring (brass)	Remove coarse soiling with damp cloth and detergent. Use brass polish to keep the original shiny surface.	Do not clean in a dishwasher. Port openings must be kept free.
Burner Head (enamel on cast iron)	Clean with detergent and brush.	Do not clean in a dishwasher.
Electrode	Clean with brush, fine glass-paper or scouring pad.	Soiled electrodes may cause malfunctions when igniting or flame control disturbance. Be careful when cleaning electrodes, they are fragile, do not turn. <b>Caution:</b> never switch on cooktop while cleaning electrodes.
Base (stainless steel, shot blasted, brushed)	Cloth with detergent and hot water. Soak burnt-in remainders with a little detergent solution. After cleaning, polish dry with a soft cloth to prevent water stains forming on the surface. For heavy soiling, you can order our stainless steel cleaner (Order No. 310631) from your Gaggenau dealer. <b>Caution:</b> no liquid should enter the housing of the cooktop through the burner base.	To prevent marring the polished stainless steel trough, always polish in the direction of the polish lines. Light discolorations may form if the natural oxidation is removed together with the soiling. Put some commercially available stainless steel polish on a cloth and polish the whole cooktop after cleaning to get an even stainless steel surface. Never allow food stains or salt to remain on stainless steel for any length of time. <b>Important:</b> certain stainless steel cleaners will scratch the surface. Chlorine or chlorine compounds in some cleaners are corrosive to stainless steel. Check ingredients on label.
Control knob	Wipe with a damp cloth.	Cloth should not be too wet, as moisture could penetrate behind the control knob.

## 9. Maintenance

---

**The appliance must be disconnected from the power and gas supply during all repair work.**

In the event of malfunctions, check whether the gas and electricity supplies are in proper working order.

The cooktop cannot be used during a power failure.

If the cooktop is being used when the power failure occurs, turn the burner control knob to the OFF position. The cooktop will not turn back on after a power failure until the control knob is first turned OFF and then turned back on again.

Before calling the service engineer, check the trouble-shooting guide on page 14 to see, if you can rectify the problem yourself. If your appliance still does not work, please contact your dealer or your local Gaggenau customer service agency. Specify the appliance type (see rating plate).

Repairs may only be carried out by authorised technicians, in order to guarantee the safety of the appliance.

Unauthorised tampering with the appliance will invalidate any warranty claims.

Only use original spare parts.

# 10. Trouble Shooting

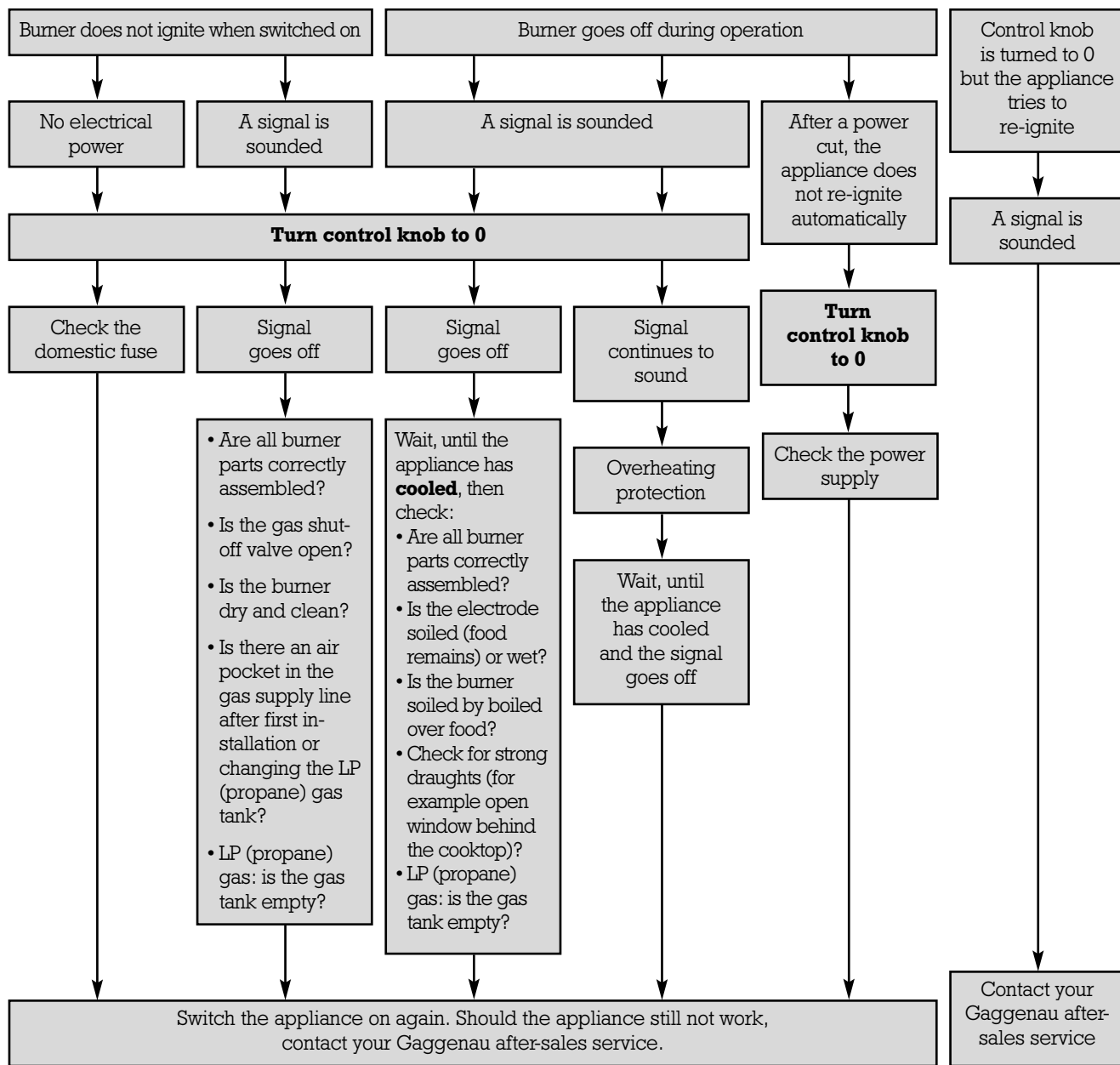

# 11. Technical Data / Nozzle Table

## Technical data (gas)

**Burners:** Full burning 5 kW  
Low burning 0.3 kW

**Gas connection:** R 1/2" union nut for R 1/2" bracket to DIN 1999, conical-cylindrical

## Technical data (electrical)

**Rated consumption** 15 W  
**Voltage** 220-240 V  
**Frequency** 50-60 Hz

**Technical modifications reserved.**

**Nozzle table wok burner**

Nozzle table wok burner				
<b>Countries</b>	AT BE CH CZ DE DK ES FI FR GB GR HU IE IS IT LU NL PL PT RU SE	DE	BE CH CZ DK ES FI FR GB GR HU IE IS IT LU NO PL PT RU	AT CH DE
<b>Gas family</b>	Natural gas	Natural gas	LPG/Propane	LPG/Prop.
<b>Gas type</b>	H / E / L (G 20/25)	LL (G 25)	3 + (G30/31)	(G30/31)
<b>Pressure</b>	20/25 mbar	20 mbar	28-30/37 mbar	50 mbar
<b>Nozzle, full burn, outer</b>	1,55	1,70 B	1,00	0,87
<b>Nozzle, low burn, outer</b>	0,73	0,81	0,51	0,45
<b>Nozzle, full burn, inner</b>	0,58	0,63	0,37	0,33
<b>Nozzle, low burn, inner</b>	0,45	0,51	0,31	0,25
<b>Air gap adjustn. outer [mm]</b>	0	0	0	0
<b>Air gap adjustn. inner [mm]</b>	*	*	*	*
<b>Total output</b>	5 kW	5 kW	5 kW	5 kW
<b>Total consumption</b>	0,50 m <sup>3</sup> /h	0,55 m <sup>3</sup> /h	360 g/h	360 g/h

\* open, fixed

## 12. Installation Instructions

---

### Important Notes

Please observe the **general safety notes** and the **important information** in chapter 1.

The **installing technician** is responsible for perfect functioning of the appliance at its installation location.

He must show the user how to switch off the electricity and gas supply whenever required.

After unpacking, check the appliance for any transportation damage and report this immediately to the transportation company.

**Note: Operation next to a downdraught ventilator VL 430/431 is not allowed.**

### Caution:

before connecting the appliance, please check whether the **local connection conditions** such as gas type, gas pressure and mains voltage match the appliance settings. This gas hob conforms to the categories that are specified on the **rating plate**.

The rating plate can be found on the appliance and additionally on the quality control slip which is included with these instructions. By replacing nozzles, it is possible to set the appliance to any gas listed on the rating plate.

If the data should not match, the appliance must be changed over to the required gas type and the available pressure.

As this gas hob is not intended for connection to an exhaust gas system, pay attention to the applicable installation conditions.

The appliance may be installed in kitchen combinations made of wood or similar combustible materials without taking additional measures. The rear wall must consist of non-combustible material.

A minimum distance of **100 mm** from heat-sensitive items of furnishing or contact surfaces (cupboard side panel) must be observed.

The hob conforms to appliance class 3 and must be installed in the worktop as shown in the installation sketch.

Do not install the appliance under a suspended cupboard. For installation under a vapour extractor, a minimum clearance of **650 mm** from the top edge of the pot stand to the bottom edge of the wall hood must be observed. If several gas appliances are installed, a larger distance from the extractor hood might be needed.

Observe the installation manual of the extractor hood. Wall trims must be heat-resistant, and the minimum distance between the hob and the wall trim is at least **35 mm**.

The appliance must be installed and connected by an authorised gas installer. The installation must conform with all current regulations of the gas supply companies and the regional construction regulations.

**Technical modifications reserved.**

## Connecting the Appliance

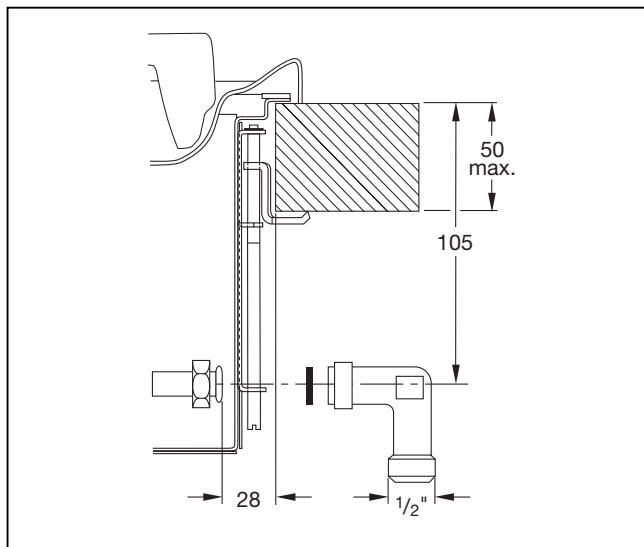

### Gas connection

The gas connection must be in a location that permits access to the shut-off valve and which, if applicable, is visible after opening the door of the cabinet.

By means of the included R 1/2" connection bracket (on the appliance end) with the affiliated washer, the appliance must be connected to a fixed connecting line or a gas safety hose to DIN 3383 Part 1 that corresponds to the type concerned.

An ambient temperature of 70 °K must not be exceeded if the gas safety hose consists only partly of metal. The permissible ambient temperature for a gas safety hose that consists completely of metal is 115 °K.

If a flexible line is used, it must be laid in such a way that it cannot come into contact with moving parts of the kitchen element (e.g. drawer).

### Electrical connection

Electrical connection (AC 220-240 V) is established by means of a connecting cable with an earthing contact plug connected to an earthed socket, which must also be accessible after installation of the gas hob.

If, after installation of the gas hob, not all poles can be isolated from the mains by removing the plug, an isolating device with a contact gap of at least 3 mm must be permanently installed. When establishing connections, make sure that the connecting lead cannot come into contact with hot parts of the gas hob or other hot parts.

Turn the control knob to the OFF position before connecting the appliance to the power supply.

The mains connecting cable must at least correspond to type H 05 V2V2 3G 0.75 or it must be correspondingly heat-resistant (at least 90 °C).

**The mains connecting cable must only be purchased through and connected by an authorised specialist.**

Pay attention to the information on the rating plate and connect the PE conductor. Connect the connecting cable to the mains.

## Preparing the Cabinet

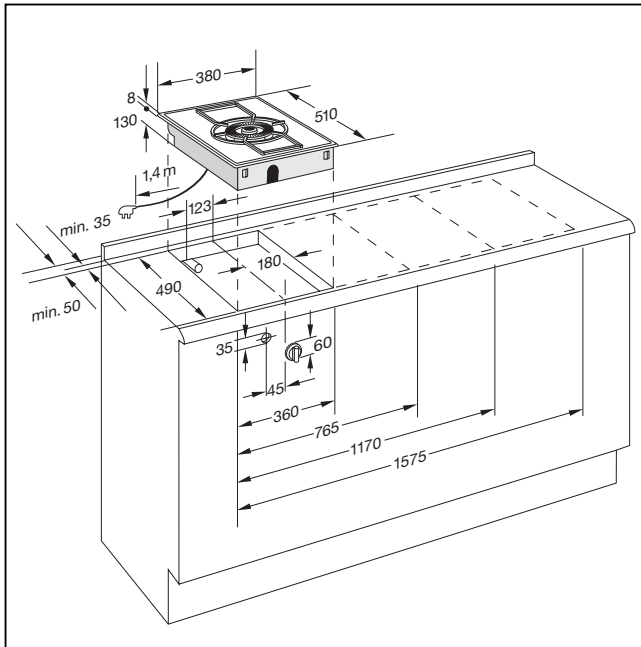

- Cut out the recess for the hob in your worktop. Proceed as indicated on the installation sketch. The installation sketch contains the measurements of the space required for the trim between the appliances. Several appliances can also be installed in individual recesses, as long as a minimum clearance of 50 mm is kept to between the appliances.
- As shown in the installation sketch, drill the  $\varnothing 35$  mm hole to secure the control knob in the cabinet front.
- If the cabinet front is thicker than 26 mm, the front must be routed from the back to max. 26 mm on an area of 80 x 310 mm.

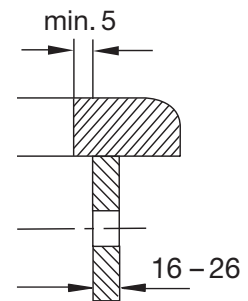
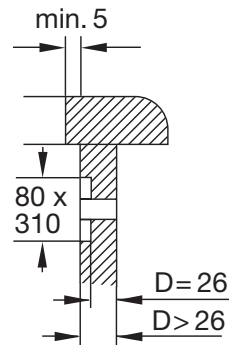

## Installing the Cooker

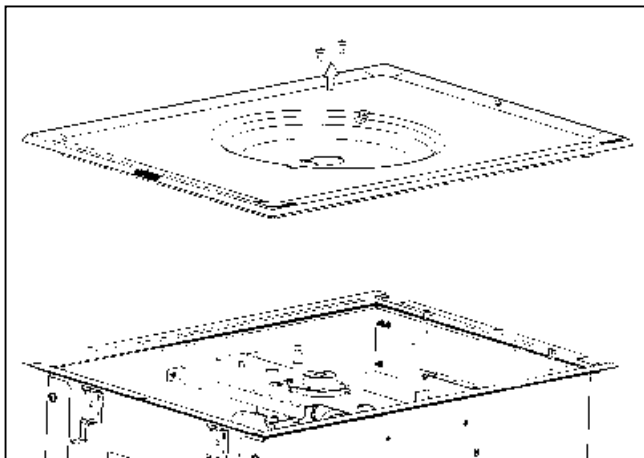
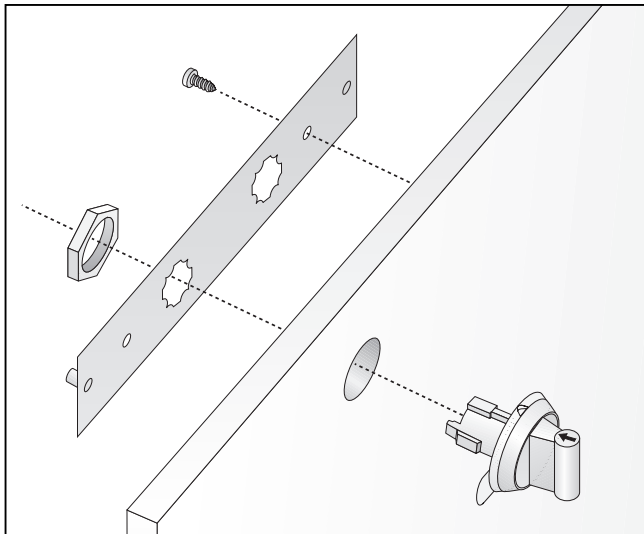

**Please note:** If you want to convert the appliance to a different type of gas, change the nozzles before installing the appliance (see pages 22 - 23).

- Before installation, remove all styrofoam packaging from the control knob and peel off the protective film.
- Hold the support plate from the rear against the cabinet front, insert control knob into the hole, secure from the rear with the nut. Secure the support plate additionally with the supplied wood screw to prevent turning.
- Undo trough securing nuts and carefully detach the trough.

**Note:** if a flexible gas connection is being used, you can connect the appliance before installing it into the worktop.

- Turn the clamping screws to the side. Insert the hob with the Gaggenau logo on the front into the cut-out and align it.

**Note:** do not stick the hob onto the worktop with silicone.

- Turn the clamping screws under the countertop and tighten them evenly. Do not tighten the clamping screws too tightly, as a uniform sealing gap should be left all round.
- Connect the appliance to the gas supply.
- Check the installation for gas leaks.

## Installing the Spindle

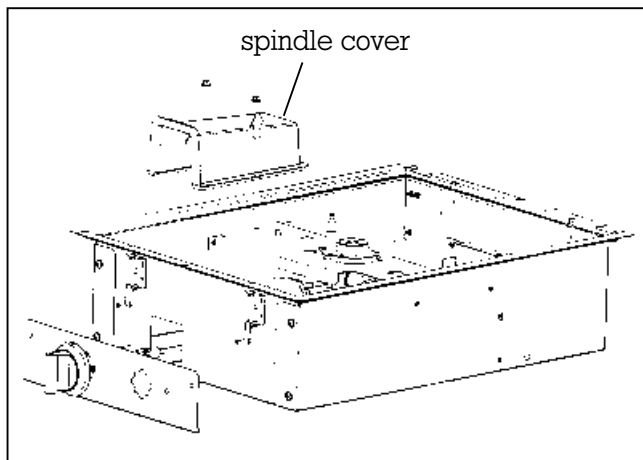
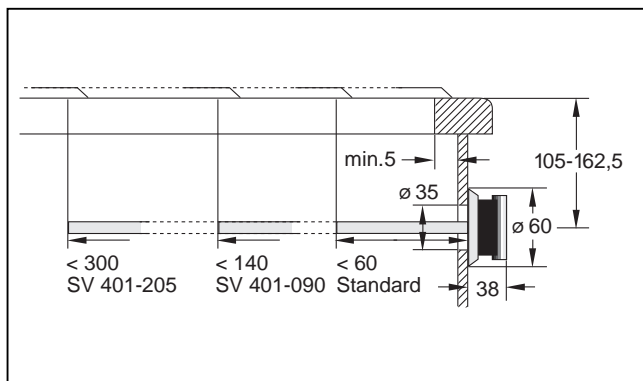

The numbers correspond to the diagram on the opposite page. Spindle extensions (SV 401-090 / SV 401-205) are available should the appliance be installed in a worktop which is non-standard depth.

Loosen the nuts of the spindle cover and remove cover.

- 1** Insert the spindle from behind into the fitting of the control knob. Be careful that the broader pin of the control knob fits the broader fitting of the spindle.
- 2** The gas tap of the burner must be in the off position (flat side to the top). Slide the spindle on the gas tap.
- 3** Fix the spindle with the screws provided.

Turn the control knob to the off position. Connect the appliance to the power supply, and check for correct functioning. If the appliance switches off there may be air in the gas supply line. Turn the control knob to the off position and relight. This may need to be repeated until the appliance ignites.

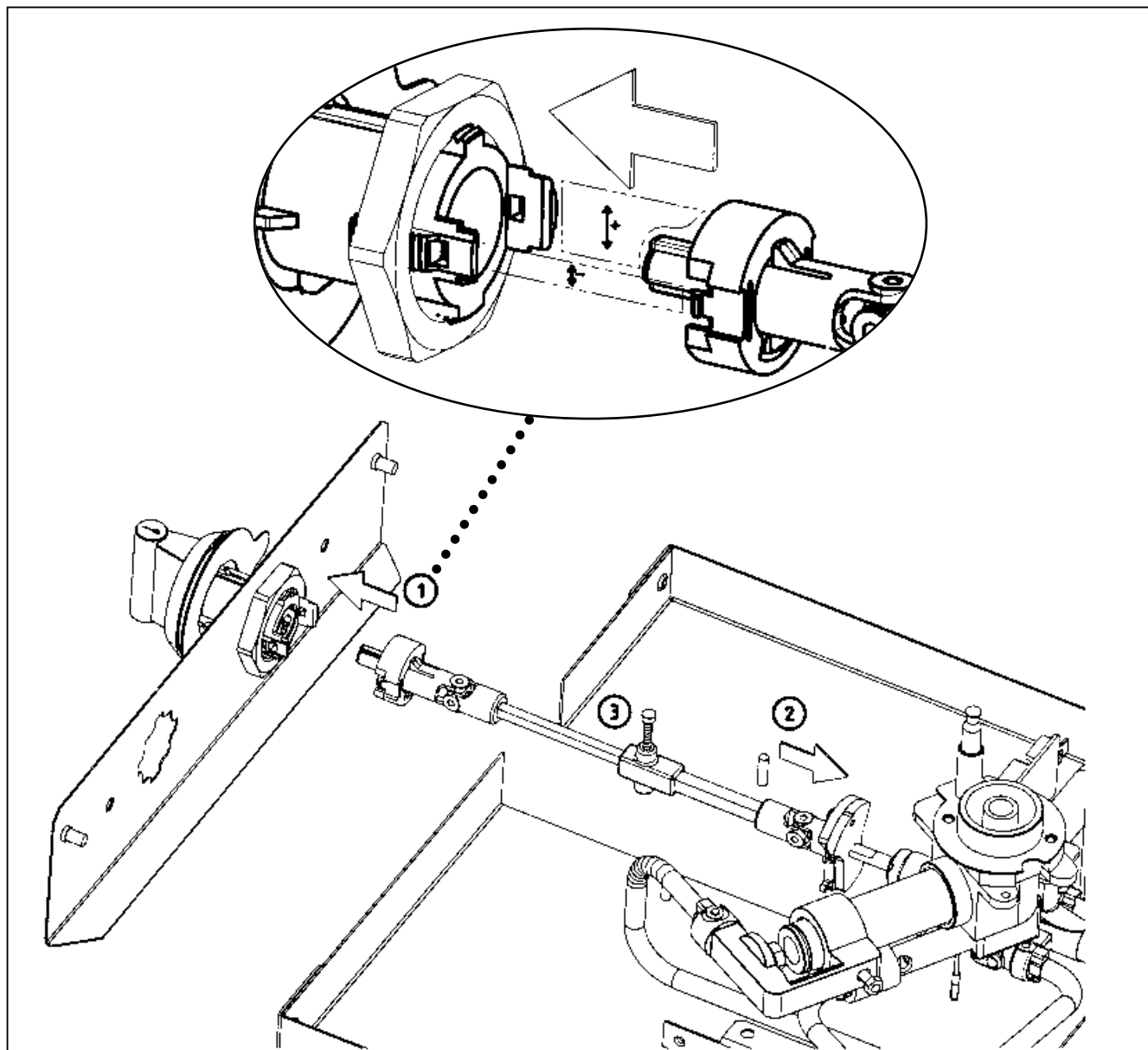

## Nozzle Replacement

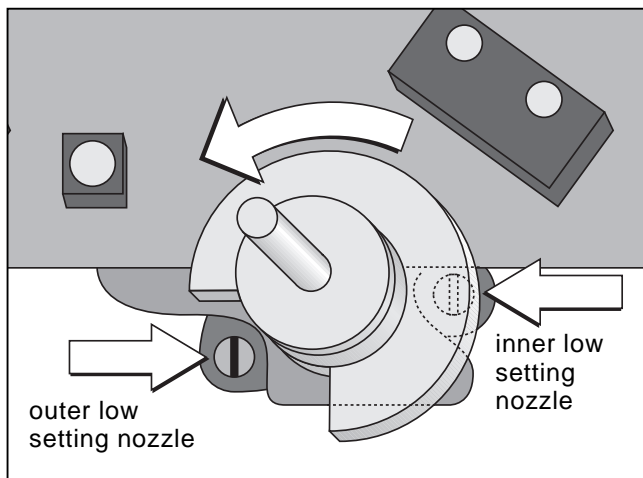

**See table on page 15  
for details of nozzle settings.**

### Changing over to a different gas type

**Only authorised specialists are permitted to change over to a different gas type.**

The nozzles needed for the gas type to be set are available as a conversion kit. Please specify the appliance type and the required gas type. The nozzles can be changed on the installed appliance.

### Loads for all gases

For all gas types and pressures, the rated load is achieved by installing the high and low setting nozzles for the required gas type (see nozzle table).

### Replacing the low setting nozzles

- Switch off the power at fuse point and close the gas supply!
- Detach pod grid, burner ring, burner head cover and burner head.
- Undo trough securing nuts and carefully detach the trough. Loosen the nuts of the spindle cover and remove cover.
- Detach the spindle between the control knob and the gas tap.
- Turn the black plastic part so that the recess is above the nozzle. Screw out nozzle and take nozzle out with small pliers.
- Replace both low setting nozzles on the gas taps according to the new gas type and as detailed in the low setting nozzle table. Fully screw in the new low setting nozzles.  
**Important:** be careful not to damage the O-ring.

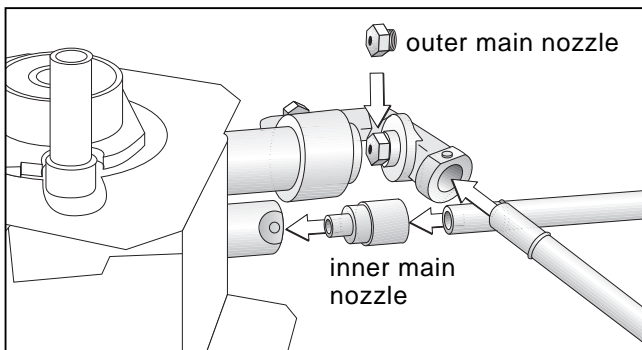

**See table on page 15  
for details of nozzle settings.**

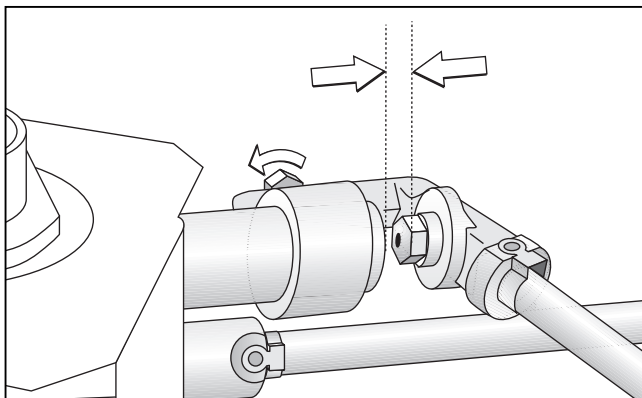
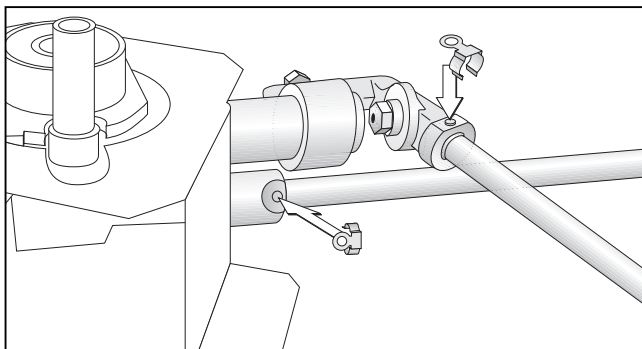

### Replacing the main burner nozzles of the wok-burner

- Unscrew the Wok burner from the trough (Torx T20). Loosen locking screw from the air regulation bush. Fully push in the air regulation bush. Detach the safety springs on the supply line. Leave the electrode connected.
- Carefully pull off the Wok burner from both supply lines. Carefully pull off the inner main nozzle with O-ring by hand. Screw out the outer main nozzle (10 mm).
- Check whether the O-ring is fitted correctly in the nozzle seat of the new inner main nozzle. Fully push nozzle onto the supply lines. **Note:** do not bend supply lines.
- Change the screw-in nozzle and tighten it firmly.
- Push the burners onto the supply lines. Push the safety springs back on.
- Screw the burner back on the trough.
- Loosen the locking screw and adjust the air regulation bush according to the nozzle table. Tighten the locking screw.
- Fit the trough and tighten it firmly.

### Checking functions

The flames are adjusted correctly if no yellow tips are visible and if they do not go out when switching over swiftly from the high to the low setting.

Please do not forget to stick the new adhesive label included with the nozzle set over the old adhesive label on the gas connection, thus documenting the changeover to a different gas type.

# **GAGGENAU**

GAGGENAU HAUSGERÄTE GMBH  
CARL-WERY-STR. 34 · D-81739 MÜNCHEN

☎ (089) 45 90-03  
FAX (089) 45 90-23 47  
[www.gaggenau.com](http://www.gaggenau.com)