



AF210760
200 series visor hood
Stainless steel frame
Width 23 9/16" (120 cm)
Air extraction / recirculation

Unobtrusive hood design thanks to integrated glass panel in the steam screen
 Especially quiet operation thanks to integrated sound insulation
 Steam screen extends by a touch of the frame
 Especially high air output
 Dimmable, warm white LED light for ideal illumination of the entire cooktop
 A patented lowering frame accessory allows the visor hood to completely disappear behind the upper cabinet
 Air extraction or recirculation system
 Recirculation kit with activated charcoal filters: quiet and highly efficient recirculation solution with odor reduction as in air extraction mode, and long replacement intervals

Output
 Sound pressure level: 60 dBA.
 500 CFM.
 Air recirculation:
 620 / 840 m³/h.
 Odor reduction recirculation 95%.

Features
 Controls at front.
 Three electronically controlled power levels and an intensive mode.
 Grease filter saturation indication by flashing light
 Stainless steel grease filter, dishwasher-safe.
 Neutral white LED light (3600 K), continuously dimmable.
 Lamp output 2 x 10 W.
 Illuminance 683 lx.
 Light can be switched on separately.
 Integrated sound insulation for quiet operation.
 The blower is activated when the steam screen is extended.
 Patented technology for extension of the steam screen.
 Steam screen extends out up to 7 13/16".
 Airflow-optimised interior for efficient air circulation and ease of cleaning.
 Patented easy mounting system for simple installation.
 The package includes an one-way flap.

Planning notes
 Patented air recirculation module with activated charcoal filter can be installed in the upper cabinet. The activated carbon filter can be exchanged by simply pulling out the filter drawer. The door of the upper cabinet must be fully accessible in order to change the activated charcoal filter.
 To be installed in an upper cabinet without base.
 The required cavity depth of the upper cabinet together with the lowering frame measures 13 3/4".
 The required cavity height of the upper cabinet together with the lowering frame measures 23 5/8".
 Minimum clearance above gas cooktops 28".
 Minimum clearance above electric cooktops 18".

Rating
 Total rating: 430 W.
 Total amps: 10 A.
 120 V / 60 Hz.
 Connecting cable 35,4" with plug.

Product Features
Operating Mode
 Convertable: Ducted / Recirculating
Number of speed settings
 3-stage
Delay Shut off modes
 3/5/10
Silence level (dBA)
Required accessories
Optional accessories
 AA210110, AA210812
Number of lights
 2
Type of lamps used
 LED
Total power of the lamps (W)
 10
Grease filter material
 Washable stainless steel
Grease filter type
 Multilayer cassette
Clean filter reminders

Consumption and connection features
UPC code
 825225918653
Material
 Stainless steel
Watts (W)
 430
Current (A)
 10
Volts (V)
 120
Frequency (Hz)
 60
Approval certificates
 intertek
Power Cord Length
 35,4
Plug type
 120V-3 prong
Overall appliance dimensions (HxWxD) (in)
 14 7/8" / 14 7/8" x 23 9/16" x 12 5/8"
Product packaging dimensions (HxWxD) (in)
 15.74 x 25.19 x 18.89
Height of the chimney (in)
Vertical rise height
Required distance above cooktop/ranges
 17/26
Net weight (lbs)
 35
Gross weight (lbs)
 39
Adjustable feet
Motor location
 Integrated motor in hood body
Maximum CFM
Diameter of air duct (in) top
Diameter of air duct (in) back
Discharge direction
 vertical
No-return airflow flap
 Yes

2016-10-07
Page 1

Color Variants

AF210760
Stainless steel frame
Width 23 9/16" (120 cm)

Optional accessories

AA210110
 1 activated charcoal filter with high efficient odor reduction due to increased surface. For air recirculation module AA 210 812.
AA210812
 Patented air recirculation kit including 1 activated charcoal filter with high efficient odor reduction

Installation Accessories

AA210460
 Lowering frame for 24" visor hood

Top cabinet for AF 210
 with lowering frame AA 210 460/AA 210 490

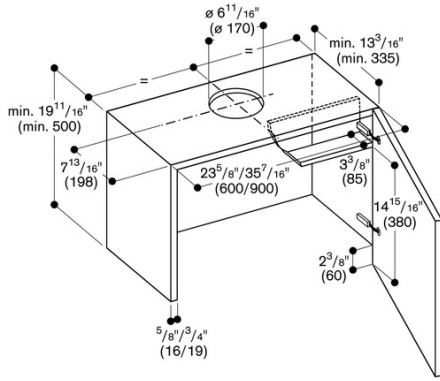

Top cabinet for AF 210

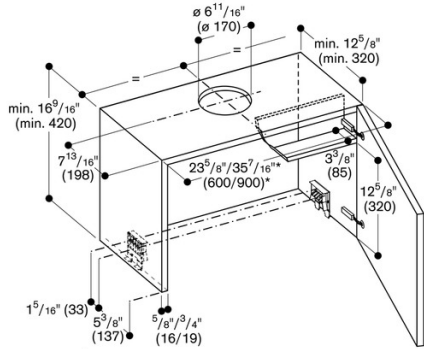

* for a 35 7/16" (90 cm) top cabinet the installation set AA 210 491 is also required

Cross-section top cabinet with AA 210 812 and lowering frame AA 210 490/460

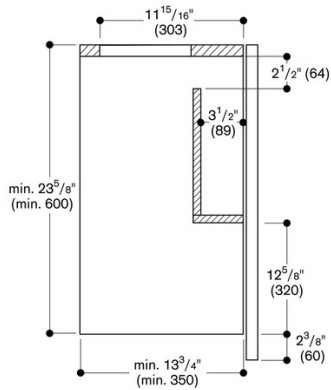

Cross-section top cabinet with AA 210 812

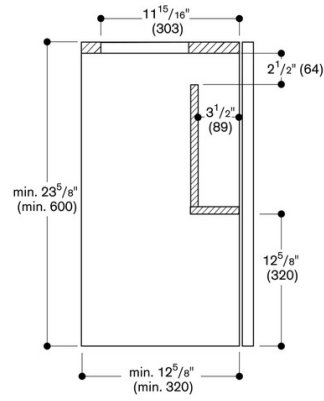

Top view of top cabinet with AA 211 812

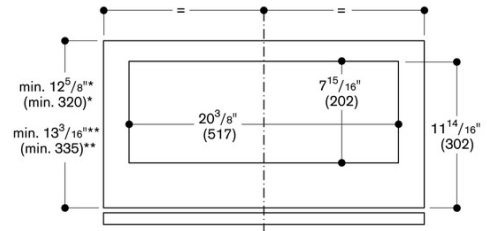

* only appliance

** Appliance with lowering frame AA 210 490/460

