

FISHER & PAYKEL

WATER FILTER REPLACEMENT INSTRUCTIONS

Ice and water refrigeration products using
water filters 836848 & 842802

INSTALLATION GUIDE
NZ AU GB IE HK SG IN US CA

Water filter

IMPORTANT!

- The water connection to your ice & water refrigerator must be installed by a qualified plumber or Fisher & Paykel trained and supported service technician and comply with all state and local laws.
- Installation and use **MUST** comply with all state and local plumbing codes. Check with your local public works department for plumbing codes. You must follow their guidelines as you install the water filtration system.
- To avoid serious illness or death, only connect your water filter to safe drinking water.
- The water filter cartridge needs to be changed when the replacement indicator icon illuminates. This will happen every 6 months.
- If the water filtration system has been allowed to freeze, replace filter cartridge. Failure to replace the disposable filter at recommended intervals may lead to reduced filter performance and failure of the filter, causing property damage from water leakage or flooding.
- In cases of excessively reduced filter life—we recommend that you consult a local plumber or your water supplier for advice on suitable filtration requirements for the water supplied to your home.
- Filter replacement is the consumer's responsibility and will not be covered by the warranty except in the case of faulty parts or materials within the filter cartridge.
- If the water has not created ice for some time or ice has an unpleasant taste or odor dispose of ice and refer to the flushing instructions in this book. If unpleasant taste or odor persists, you may wish to fit a new filter cartridge.
- Your water filtration system can withstand up to 120psi (827kPa) of water pressure. Ensure the supplied pressure-reducing valve is installed before installing the water filtration system. **DO NOT** install if water pressure exceeds 120psi (827kPa).

To reduce the risk associated with property damage due to water leakage or flooding:

- **DO NOT** install systems in areas where ambient temperatures may go above 100°F (38°C) or drop below 33°F (0.6°C).
- **DO NOT** install on hot water supply lines. The maximum operating water temperature of this filter system is 100°F (38°C).
- **DO NOT** install where water hammer conditions may occur. If water hammer conditions exist, you must install a water hammer arrester.

Replacement filter cartridges can be purchased online at fisherpaykel.com or by calling Fisher & Paykel Customer Care. Details of the replacement filter cartridge are labelled on the cartridge.

Office address

Fisher & Paykel Appliances Ltd
PO Box 58550
Botany
Auckland 2163
New Zealand

Customer Care

Phone: +64 9 273 0660

② FOR REFRIGERATORS WITH EXTERNAL FILTER

Note: It is not necessary to turn the water supply off when removing or installing the water filter.

Removing the old filter

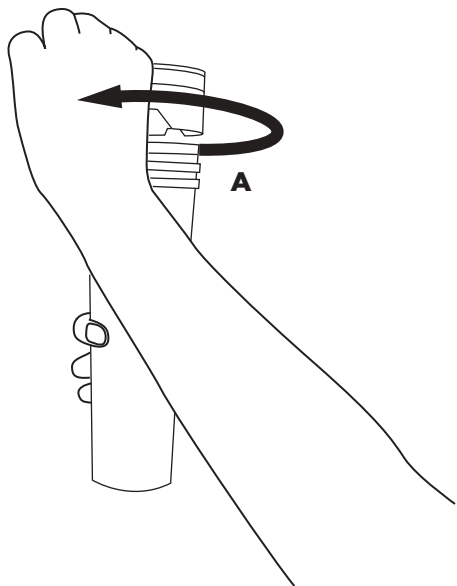

- ① Grasp and firmly twist the cartridge in an anti-clockwise direction (**A**) (to the left when installed in the recommended orientation).

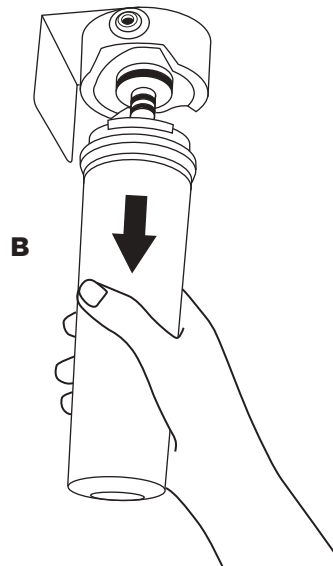

- ② Pull the cartridge away from the filter head (down when installed in the recommended orientation).
 - It is not unusual for a few drops of water to be present when the filter is removed.

Discard the old filter.

Installing the new filter

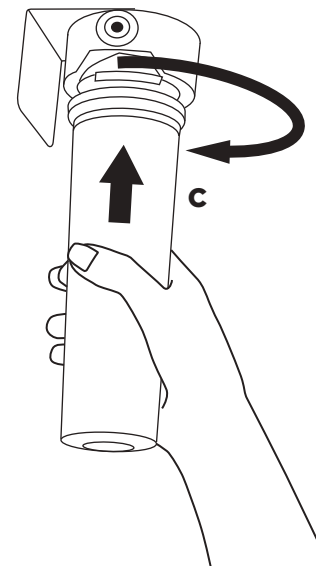

- ① Remove the plastic wrapping from the new filter and then remove the protective cap.
- ② Align the filter correctly. Insert the filter into the filter head and rotate in a clockwise direction (**C**) (to the right when installed in the recommended orientation).

IMPORTANT!

After installation, the water filter MUST be flushed. Refer to 'Flushing the water filter' for details.

3 FOR ACTIVESMART™ INTEGRATED REFRIGERATORS

Note: It is not necessary to turn the water supply off when removing or installing the water filter.

Removing the old filter

The filter is located behind the toe kick grille.

- 1 Remove toe kick grille by inserting fingers into the left and right square openings on the grille. Pull grille towards you.
- 2 Pull the freezer drawer out slightly, the filter is located on the left-hand side.

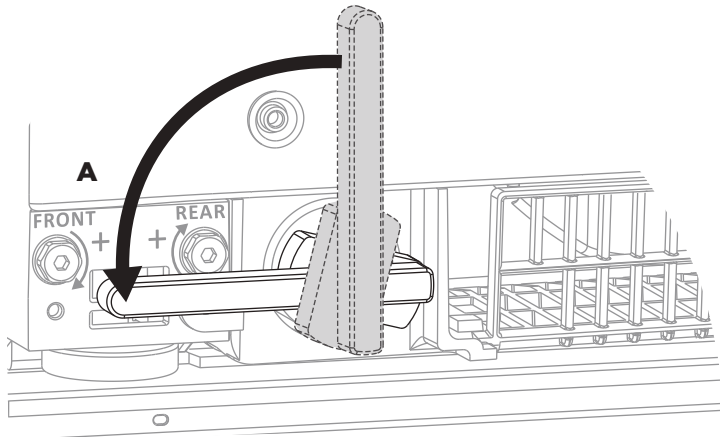

- 3 Using the filter removal tool, align the tool to the cartridge handle and turn 90° counterclockwise to loosen (A).
- 4 Remove the tool, grasp firmly onto the cartridge handle and pull towards you to remove. Discard the old filter.

Installing the new filter

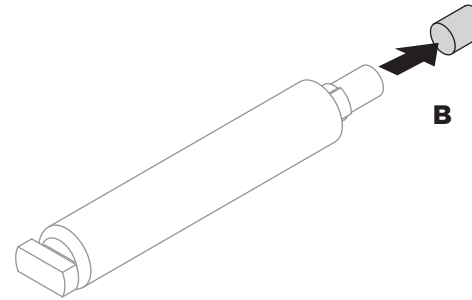

- 1 Remove the plastic wrapping from the new filter and then remove the protective cap (B).
- 2 Remove toe kick grille by inserting fingers into the left and right square openings on the grille. Pull grille towards you.

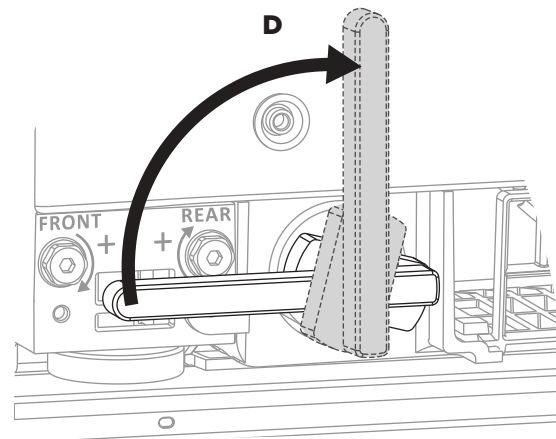

- 5 Rotate the filter head clockwise 90° to lock in place (D).

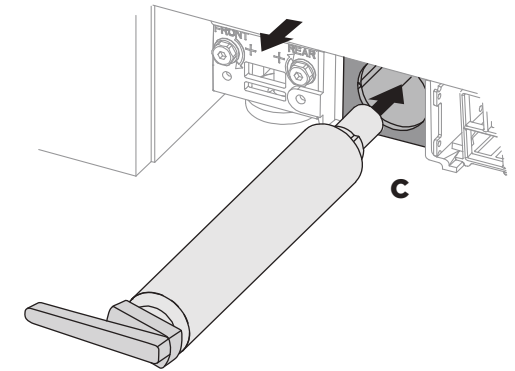

- 3 Pull the freezer drawer out slightly to access the filter casing. Align the filter correctly (C).
- 4 Using the filter tool, push the filter firmly inside the casing all the way into the filter head.

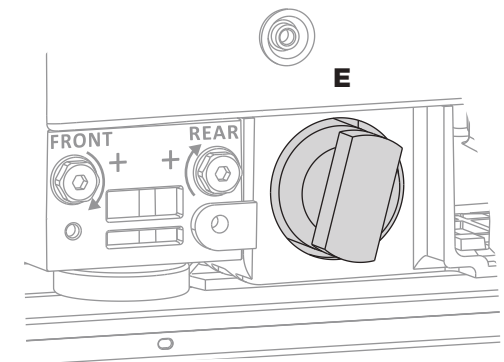

- 6 Ensure the filter is in the locked position (E). Remove filter removal tool and close the freezer drawer.

IMPORTANT!

After installation, the water filter MUST be flushed. Refer to 'Flushing the water filter' for details.

④ WATER FILTER FLUSHING INSTRUCTIONS (ALL MODELS)

Flushing the water filter

- Check your refrigerator is switched on.
- Allow at least 2 hours for your appliance to cool before use.
- Complete all the flushing steps detailed in this document to ensure optimum performance of your water filter.

For Ice & Water only models:

Flushing must be completed through both the water dispenser and ice maker.



For Automatic Ice only models:

Flushing must be completed through the ice maker.

Flushing through water dispenser

- ① Press the water dispenser pad to dispense 1 gal (4L) of water.
 - A harmless carbon residue may be dispensed with water during the flushing process.
- ② Wait for 4 minutes before dispensing again.
- ③ Dispense 1 gal (4L) of water then wait another 4 minutes.
- ④ Dispense another 1 gal (4L) of water. Your water dispenser is ready for use.
- ⑤ Water will continue to drip from the dispenser for a few more days after installation to clear remaining trapped air in the dispenser. Check the drip tray regularly and empty when required.

Flushing through ice maker

- ① Turn the ice maker on, refer to the user guide supplied with your appliance for details.
- ② Press the ,  and  together for 4 seconds then close the doors. The ice tray will flip twice and empty the water into the bin below.
 - The ice tray will flip only after the doors are closed.
- ③ Repeat step ② to remove dust in the ice tray collected during manufacture and transport.
- ④ Empty the water from the ice bin and return it correctly.
- ⑤ Once your ice maker is turned on, the first bin of ice may be discolored, this is not harmful and normal during the flushing process. Discard the first full bin of ice made. Your ice maker is ready for use. The performance of your water filter will improve with continued use.

For Ice & Water only models:

The water filter will reach optimum performance after two to three full bins of ice.





For Ice only models:

The water filter will reach optimum performance after four to five full bins of ice.

Resetting the filter indicator

Use the water filter as soon as possible after installation. A replacement indicator  on the control panel and/or external display illuminates when you need to replace the filter. Reset the indicator only after replacing the filter.

To reset indicator

- Press  and  together for 4 seconds.
- The  on the control panel will turn off when reset.
- The filter change indicator icon  on the control panel and/or external display will turn off when reset.

IMPORTANT!

- **We recommend the water filter to be used from the time of installation.**
- **Do not reset indicator before filter is changed or filter monitoring will be inaccurate.**

FISHERPAYKEL.COM

© Fisher & Paykel Refrigerators 2018. All rights reserved.

The product specifications in this booklet apply to the specific products and models described at the date of issue. Under our policy of continuous product improvement, these specifications may change at any time. You should therefore check with your Dealer to ensure this booklet correctly describes the product currently available.

851554A 10.18