



FF1935PL



73" x 29.25" x 27" (H x W x D)

Counter depth 18 cu.ft. frost-free refrigerator-freezer in platinum finish, part of the Ingenious Series designed for true user convenience in the kitchen

Highlights:

Part of the Ingenious Series of refrigerator-freezers, designed with extra care for modern user convenience

Over 18 cu.ft. of interior storage inside a convenient counter depth fit

Modern platinum finish offers an attractive look for any kitchen

Deluxe interior includes spillproof glass shelves and multiple crispers

Product Features:

Frost-free operation	Ensures low maintenance operation by eliminating the manual defrosting process
Platinum finish	Stylish look suits many kitchen styles
Adjustable safety glass shelves	Rearrange refrigerator and freezer space to accommodate all sizes or remove shelves for simple cleanup
Door storage	Full and half shelves in both compartments, with a large refrigerator door shelf that can accommodate gallon-sized containers
Smart Station	Unique door compartment lets you store selected items in a way that's easily accessible without opening the door
Express Chill Zone	Special freezer feature lets you cool down items quickly in 60, 45, 30, 20, 15, or 10 minute increments, with an audible alarm to tell you when your item is ready
Humidity controlled crisper	Large crisper drawer offers the ideal conditions for storing produce
Deli crisper	Clear drawer compartment is ideally designed for deli storage
Sliding mini-crisper	Great for smaller items, the compact crisper can be moved from side to side for added flexibility



FF1935PL Specifications:

Overview	
Height	73.0"
Width	29.25"
Width with Door Open	31.75"
Depth	27.0"
Depth with door at 90°	54.5"
Capacity	18.12 cu.ft.
Defrost Type	Frost-Free
Door	Platinum
Cabinet	Platinum
US Electrical Safety	UL
Canadian Electrical Safety	ULC
Energy Usage/Year	472.0kWh/year
Amps	1.3
Voltage/Frequency	115 V AC/60 Hz
Weight	203.0 lbs.
Shipping Weight	220.0 lbs.
Parts & Labor Warranty	1 Year
Compressor Warranty	5 Years
Refrigerator-Freezer	
Door Swing	RHD
Reversible	No
Crisper Qty	2
Crisper Finish	Transparent
Crisper Cover	Glass
Refrigerator - Shelf Type	Glass
Refrigerator - Shelf Qty	2
Refrigerator - Full Door Shelves	2
Refrigerator - Half Door Shelves	2
Freezer - Shelf Type	Glass
Freezer - Shelf Qty	1
Freezer - Full Door Shelves	1
Freezer - Half Door Shelves	1
Adjustable Shelves	Yes
Gallon Door Storage	Yes
Interior Light	Yes

Thermostat Type	Digital
Fan Type	Interior
Refrigerant Type	R134a
Refrigerant Amount	4.2 oz.
High Side PSI	335.0
Low Side PSI	140.0
Level Legs	2
Wheels	2

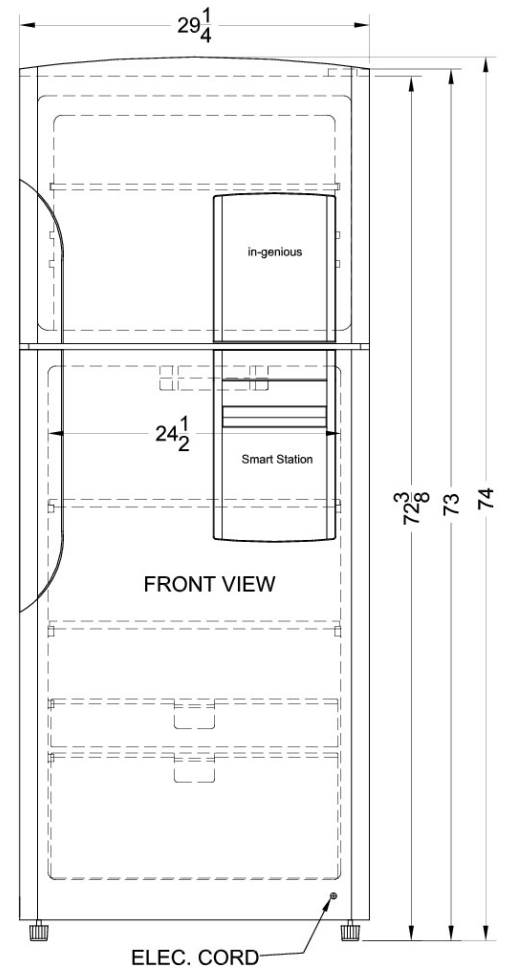
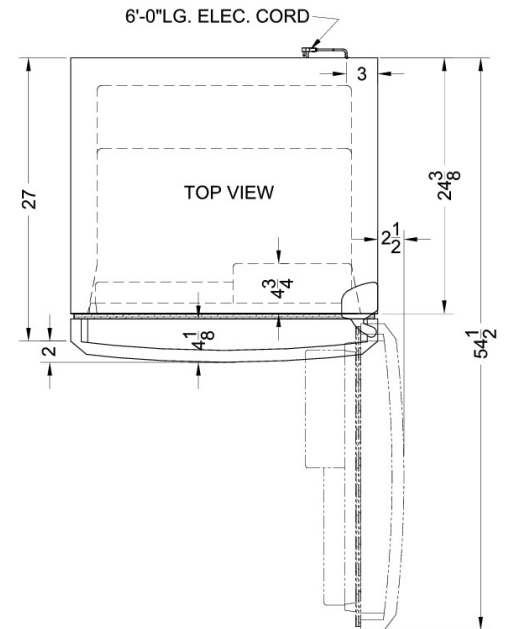

SUMMIT APPLIANCE DIVISION FELIX STORCH, INC.

770 Garrison Avenue, Bronx, NY 10474 USA TEL 718-893-3900 FAX 844-478-8799

info@summitappliance.com

www.summitappliance.com