

5.83 Cubic Foot Built-In Beverage Center

BC100GS

Available



Unit Specifications

Width	23 7/8"
Depth	25 1/2" (including handle)
Height	34 9/16" (including hinge)
Weight	121.5 lbs.
UPC	688057381978

More Easy-To-Use Features

- Stores up to 150 Cans
- 2 Glass Shelves
- Fold Away Shelf
- Temperature Range 34° – 50° Fahrenheit
- Sabbath Mode
- Door Ajar Alarm
- Storage Basket
- Zero Degree Door Clearance
- S/S Door w/ 3/4" Pro Style Handle
- Reversible Door
- Soft Lighting (Auto/Manual)
- Electronic Controls (Celsius/Fahrenheit)

Signature Features

Electronic Control Display

Electronic temperature controls allow for precise temperature settings in one-degree

Reversible Door Hinge

Zero Obstructions. Zero Hassle. Maximize convenience during the installation process with the innovative field reversible door

Adjustable Leveling Feet

Provides flexibility to account for varying surface levels

Available Finishes



Stainless Steel

ADA

Letter	Cutout Dimensions	in.
A	Height	35"
B	Depth	24"
C	Width	24"
D	Depth (door open 90°)	46 3/8"

Overall Packaging Details

Packaging	lb./in.
Gross Weight	163.7 lbs.
Dimensions	W 26 1/4" D 28 1/4" H 37 1/4"

Power Requirements

Electrical Rating	115V, 60Hz
-------------------	------------

Product Technical Illustration

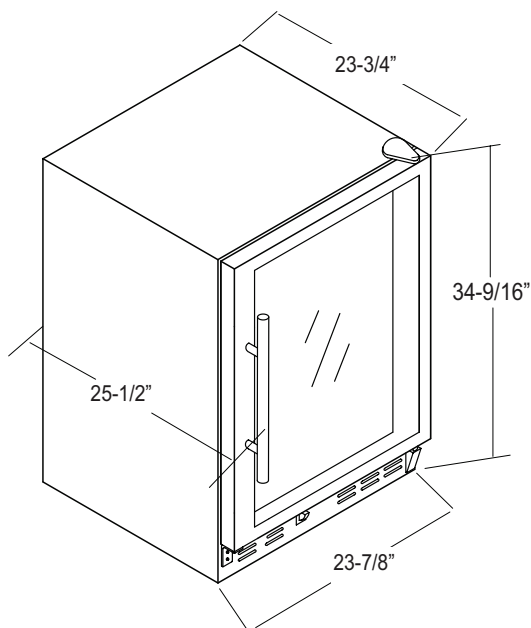

General Appliance Information

Please read all installation details and instructions before use.

Contact Us

For questions regarding this product please refer to our website at haieramerica.com or call our customer service center at 877-337-3639.

