

Dear Customer,

Thank you for choosing this quality product from ASKO. We hope it will meet your expectations and fulfill your needs for many years to come. Scandinavian design combines clean lines, everyday functionality, and high quality. These are key characteristics of all our products and the reason they are greatly appreciated throughout the world.

To ensure that you get the most out of your new machine, we recommend that you read the operating instructions before using the machine. The operating instructions also contain information on how to avoid damaging the environment.

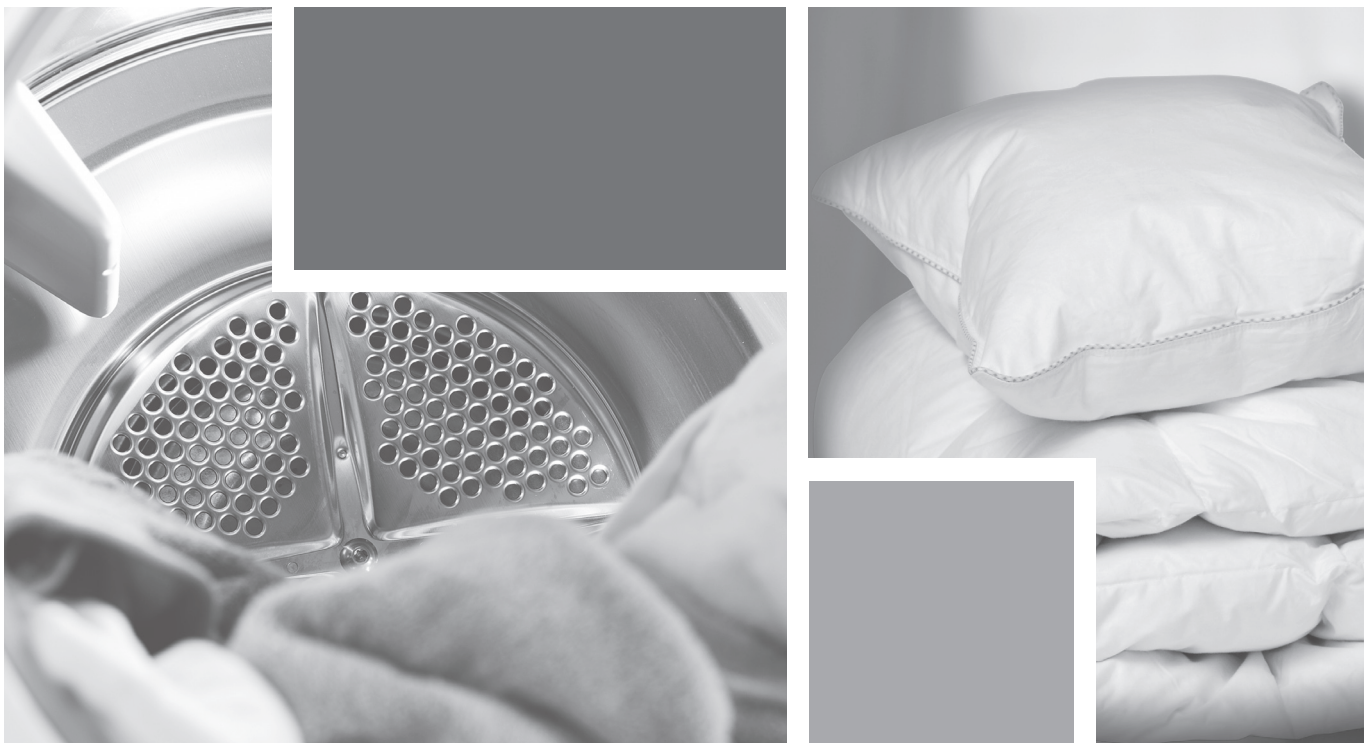

Operating Instructions

Tumble dryer
ASKO T754C W

WARNING: Read the instructions before using the machine.

Contents

Before using your machine for the first time	3	Care and maintenance instructions	14
Important safety instructions	4	Cleaning the lint filter	14
Grounding instructions	5	Cleaning the outside of the machine	14
Packing material	5	Cleaning the condenser	15
Disposal	5	Troubleshooting	16
Child safety	6	The machine will not start	16
General	6	The machine loses all power during a program	16
Description of the tumble dryer	7	Drying takes too long	16
Advice and tips before you tumble dry	8	Error messages	16
Materials that can be tumble dried	8	Technical information	17
Materials that should not be tumble dried	8	Technical data	17
Static electricity	8	Service and guarantee	18
Operating instructions	9	Limited Warranty – Residential Appliances	18
Sort your fabrics	9	Installation instructions	21
Press the main power switch until the display lights.	9	Positioning the tumble dryer	21
Open the door, load the items, and then close the door	9	Built-in	23
Select the program	10	Condensed water	24
Selecting Options	12	Electrical installation	25
Press the Start button	13	Reversing the door	28
Drying program finished	13	Follow these instructions:	29
		Quick guide	32

Before using your machine for the first time

Do you need this Use&Care Guide in Spanish? Log on to www.askona.com/customer-care to download. ¿Necesita esta Instrucciones de uso y cuidado en español? Entre en www.askona.com/customer-care. y descárguesela.

Laundry labels

Certain materials are not suitable for tumble drying. Always check and follow the instructions on each item's laundry label. You can find more information in the Advice and tips before you tumble dry chapter.

NOTE!

When starting the tumble dryer for the first time or after a long period without use, you may hear a slight thumping noise. This noise is completely normal and will disappear after a few loads.

Important safety instructions



SAVE THESE INSTRUCTIONS FOR FUTURE REFERENCE

WARNING!



WARNING - To reduce the risk of fire, electric shock, or injury to persons when using your appliance, follow basic precautions, including the following:

- Read all instructions before using the appliance.
- Do not wash or dry articles that have been previously cleaned in, washed in, soaked in, or spotted with gasoline, dry-cleaning solvents, cooking oils, other flammable or explosive substances as they give off vapors that could ignite or explode.
- Do not allow children to play on or in the appliance. Children should be closely supervised when near the appliance.
- Before the appliance is removed from service or discarded, remove the door to the drying compartment.
- Do not reach into the appliance if the drum is moving.
- Do not install or store this appliance where it will be exposed to the weather.
- Do not tamper with controls.
- Do not attempt to repair or replace any part of the appliance or perform any servicing unless specifically recommended in this guide.
- Do not use fabric softeners or dryer sheets unless the manufacturer gives written assurance that the product will not damage a tumble dryer.
- Do not heat dry items containing vinyl, plastic, foam rubber or similarly textured rubberlike materials, fiberglass, or wool unless the label specifies "washable".
- Clean the lint filter before or after each load.
- Keep the area around the exhaust opening and adjacent surrounding areas free from the accumulation of lint, dust and dirt.
- The interior of the machine should be cleaned periodically by an authorized ASKO service agent.
- Do not place items exposed to cooking oils in your dryer. Items contaminated with cooking oils may contribute to a chemical reaction that could cause a load to catch fire.
- Electrical installation, if required, must be done by a licensed electrician.
- Do not operate appliance while away from the home.
- Do not heat dry items that have been dry-cleaned.
- The dryer is made and marked to facilitate recycling. When it is no longer useful, contact your local refuse collection service for advice on how to properly dispose of the dryer for purposes of recycling.
- Damaged power cables should only be replaced by a certified professional.
- Provide sufficient ventilation, otherwise smoke from open fires or fumes from equipment burning other fuels can be drawn into the room.

CAUTION!

During the program, the back of the dryer will get very hot. Let the machine cool completely before touching the back.

WARNING!



This appliance must be properly grounded.

Important safety instructions



Grounding instructions

A) Grounding instructions for a grounded, cord-connected appliance

In the event of malfunction or breakdown, grounding will reduce the risk of electric shock by providing a path of least resistance for electric current. This appliance (Canadian market only) is equipped with a cord having an equipment-grounding conductor and a grounding plug. The plug must be plugged into an appropriate outlet that is properly installed and grounded in accordance with all local codes and ordinances.

WARNING!



Improper connection of the equipment-grounding conductor can result in a risk of electric shock. Check with a qualified electrician or service representative or personnel if you are in doubt as to whether the appliance is properly grounded. Do not modify the plug provided with the appliance (Canadian market only). If it will not fit the outlet, have a proper outlet installed by a qualified electrician.

To reduce the risk of fire, this appliance must be exhausted outdoors or the equivalent. Do not exhaust into a chimney, wall, ceiling or concealed space in a building.

B) Grounding instructions for a permanently connected appliance:

This appliance must be connected to a grounded metal, permanent wiring system, or an equipment-grounding conductor must be run with the circuit conductors and connected to the equipment-grounding terminal or lead on the appliance.

NOTE!

This manual does not cover every possible condition and situation that may occur. Use common sense and caution when installing, operating, and maintaining any appliance.

Installation

See the section Installation instructions.

Packing material

Please sort waste materials in accordance with local guidelines.

Disposal

This machine is manufactured and labeled for recycling. In order to prevent personal injury, the machine must be made inoperable after deciding to take it out of service. Contact your municipality for information about where and how your machine can be recycled correctly.

Child safety

General

WARNING!



Do not allow children to play with the tumble dryer.

- If the door is opened when a program is running, the garments may be very hot, with a risk of burn injuries.
- The tumble dryer does not start automatically when the door is closed (if a child pulls the door shut from the inside, for example).

Description of the tumble dryer

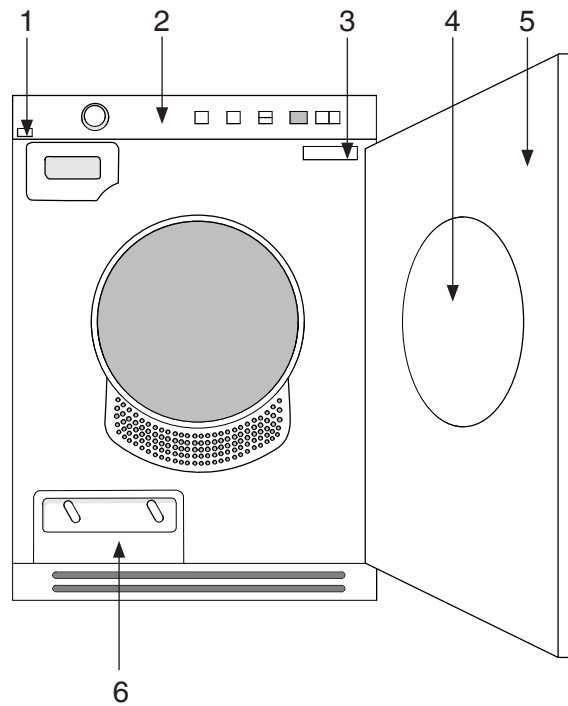

- | | | | |
|----|------------------------------------|----|-------------|
| 1. | Main power switch | 4. | Lint filter |
| 2. | Panel | 5. | Outer door |
| 3. | Serial number tag and rating plate | 6. | Condenser |

Advice and tips before you tumble dry

Here are some tips that may help you before you begin tumble drying.

Have the clothes been spun?

Items to be tumble dried should be spun at 1000 rpm or faster. Higher spin speeds save energy and reduce drying time.

Materials that can be tumble dried

This symbol means that the material is suitable for tumble drying. Fabrics best suited to tumble drying are cotton fabrics, terry cloth, and synthetic fibers. Garments will be softer and lighter when tumbled than when hung out to dry.

NOTE!

The tumble dryer does not cause any significant wear on fabrics. The lint trapped in the lint filter consists of dust and fiber residues formed when the items are used.

Materials that should not be tumble dried

This symbol means that the material is not suitable for tumble drying. Certain materials may melt or become a fire hazard if exposed to heat and others can lose their shape or shrink.

And do not tumble dry

- materials labeled "Do not dry near heat".
- garments that have been dry-cleaned at home.
- plastic foam.
- fiberglass material.
- wool must not be tumble dried due to the risk of piling.

Static electricity

To reduce the risk of static electricity in the laundry after tumble drying, you can:

- Use fabric softener when washing.
- Wait five minutes after the drying program ends before opening the door and removing the laundry from the dryer.

NOTE!

You can stop the tumble dryer by pressing the Stop button for three seconds or by opening the door. In both cases the program is stopped and starts from the beginning if restarted.

If you do not want to restart the program, immediately remove all laundry and spread it out to allow the heat to dissipate.

Operating instructions

WARNING!



To reduce the risk of electric shock or injury to persons, read the "Important Safety Instructions" section before operating this appliance.

Below are step-by-step instructions to help you achieve the best possible tumble drying results.

1 Sort your fabrics

You will achieve the most uniform drying results if the items are made of the same type of material. Close zippers and fasten buttons or belts; sort the items and adjust load and temperature.

2 Press the main power switch until the display lights.

NOTE!

Power on

Press the on/off button for min. 1 sec and max. 5 sec.

Power off

Press the on/off button for min. 5 sec.

If the ON/OFF command is not correctly accepted by the machine, wait min. 8 sec before any further press.

3 Open the door, load the items, and then close the door

Operating instructions

4 Select the program

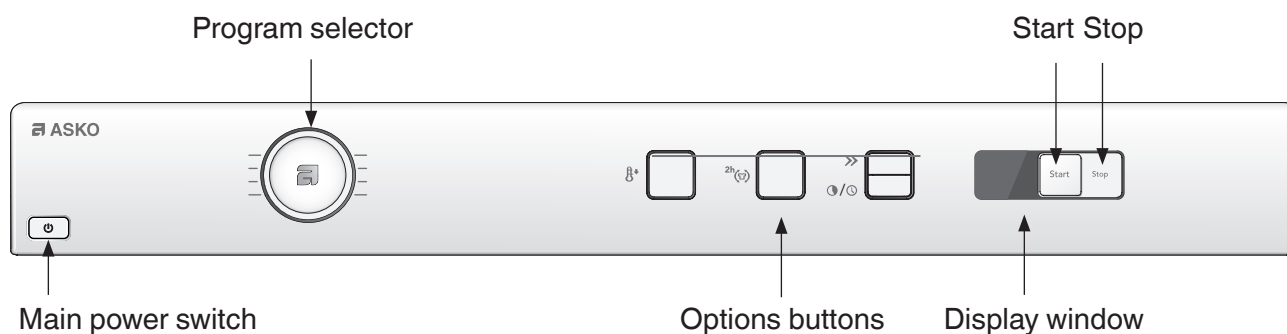

Select a program by turning the program selector. An LED lights next to the selected program. Use the option buttons to select any options.

Guidelines as to what specific programs can be used for:

Auto Heavy

Program with the maximum temperature. This program is for items that are particularly difficult to dry, such as jeans with very thick seams.

NOTE!

Knitted fabrics in particular are prone to shrinkage. Use the Auto Normal, Auto Delicate, or Auto Iron Dry programs for these items. Stretch clothes back into shape immediately after drying.

Auto Normal and Auto Delicate

These programs end automatically when the load is dry. The Auto Normal program leaves the laundry slightly more dry than Auto Delicate.

Auto Iron Dry

This program shuts off the heat once the load is just damp enough for ironing or pressing.

Timed Dry

The most suitable program time depends on what you intend to do with the items after tumble drying them. Use trial and error to find

out what works best. When you use Timed Dry to tumble dry a load of mixed fabrics, some of the garments may remain damp. Tumble dry any damp garments for a further 30 minutes or so using the Timed Dry program. Select the desired time by pressing the Delayed Start button. A program time between 30 minutes and 3 hours can be selected and each button press changes the time by 15 minutes.

NOTE!

When using the Timed Dry program with a program time that is too long, the garments can become "over-dry". This can cause items to shrink or wrinkle and feel rough to the touch. Synthetic materials can also become charged with static electricity.

Air Fluff

Use the Air Fluff program when you just want to refresh, air out, or soften up items. Select the desired time by pressing the Delayed Start button. A program time between 15 minutes and 3 hours can be selected and each button press changes the time by 15 minutes.

Operating instructions

Program chart

Here we present the energy and time consumption of a few different programs. The table shows the effect of using different spin speeds when washing the load. Consumption can vary depending on room temperature, humidity, load, variations in the power supply, and selected options.

For the consumption values given below, the requirements are as follows:

Temperature of intake air: 73 °F (23 °C)

Moisture content of intake air: 55 %

Drying temperature: Normal

Heater output: 2500W

Program	Material	Load	Spin speed (rpm)	Energy consumption, approx. (kWh)	Program time, approx. (min)
Auto Heavy	Cotton, linen	1/1	800	4.5	2:00
			1000	4.2	1:50
			1400	3.7	1:40
			1600	3.5	1:35
Auto Normal	Cotton, linen	1/1	800	4.3	1:50
			1000	3.9	1:45
			1400	3.4	1:30
			1600	3.2	1:25
	Wrinkle-resistant, polyester/cotton	1/2	1000	2.0	1:00
Auto Delicate	Cotton, linen	1/1	800	4.2	1:50
			1000	3.92	1:40
			1400	3.3	1:25
			1600	2.8	1:15
	Wrinkle-resistant, polyester/cotton	1/2	1000	1.41	0:40
Auto Iron Dry	Cotton, linen	1/1	800	4.1	2:05
			1000	3.50	1:45
			1400	2.8	1:30
			1600	2.2	1:10

Operating instructions

5 Selecting Options

By selecting options, you can tailor a drying program to suit your requirements. The available options depend on the selected program. Once you have started the program, the options you selected are saved for the next time you use the same program.

Temperature Low

You can select Temperature Low with all programs except Air Fluff and Timed Dry.

- Select Temperature Low by pressing the button next to the symbol.
- The lamp next to the button lights when Temperature Low is selected.

Time saver

You can select Time saver with all programs except Air Fluff. The program is shortened by about 12 minutes.

- Press the button next to the symbol.
- The lamp next to the button lights when Temperature Saver is selected.

Anti Wrinkle

This option means that the drum will rotate for three seconds per minute for two hours after the drying program has finished. If you are unable to remove the items immediately after the program has finished, this option prevents the garments from remaining in the same position and becoming wrinkled. Cannot be selected with the Air Fluff program.

- Select Anti Wrinkle by pressing the button next to the symbol.
- The lamp next to the button lights when Anti Wrinkle is selected.

Delayed Start

Select a program and then press Delayed Start. Press the button to select a delayed start of 1 to 24 hours. The lamp next to the button lights when this option is activated. Next, press Start and the machine will count down 1 hour at a time and start after the selected delay. To cancel Delayed Start, press and hold Stop for three seconds. Delayed Start cannot be selected with Timed Dry or Air Fluff.

Operating instructions

6 Press the Start button Remaining drying time

An estimate of the remaining drying time will be shown on the display a few minutes after the drying program starts. 1:35 means that it will take approximately 1 hour and 35 minutes for the load to dry.

The actual remaining time may be longer than the estimated time shown on the display. The remaining time is then shown as 0:15 until the laundry is sufficiently dry. If you selected Time saver, the display will show 0:05 instead.

You can stop the tumble dryer by pressing the Stop button or by opening the door. In both cases the program is stopped and starts from the beginning if restarted.

NOTE!

The program will not be affected if you change the program selector after the program has started.

7 Drying program finished

The text "End" is shown on the display for 2 minutes. The machine then turns off.

NOTE!

- Clean the lint filter in the outer door after each load. See the Care and maintenance instructions chapter.

To install the automatic drain hose, please see the section titled Installation

WARNING!



If the lint filter becomes clogged, the machine's automatic overheating cut-out may be triggered. Clean the filter, wait until the machine has cooled, then try starting it. If it still does not start: Call the Customer Care Center.

Once drying has finished

Remove the clothes and close the door to prevent small children from climbing into the machine.

Care and maintenance instructions

Cleaning the lint filter

The lint filter must be cleaned after each load.

1. Lift the filter from the holder in the door.

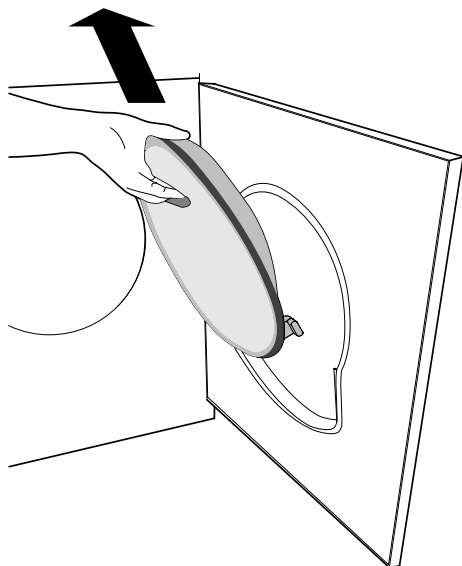

2. Open the lint filter. Use your thumb to press on the edge as illustrated and pull it out.

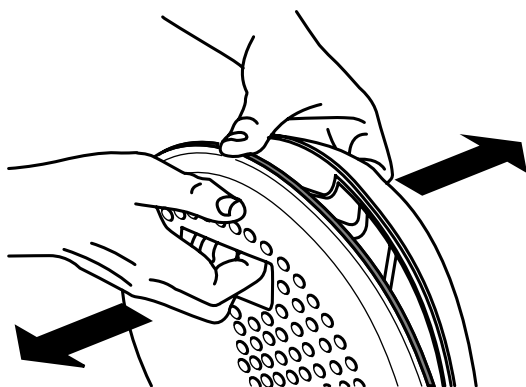
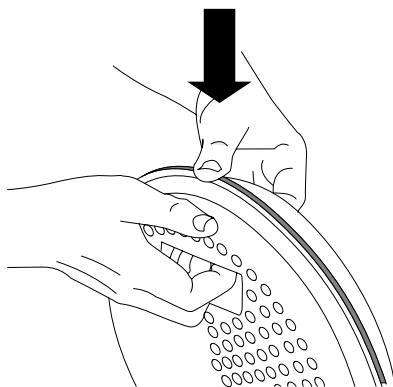

3. Use your hand or a soft cloth to remove the lint from all sides of the filter. If necessary, use a damp sponge and a small amount of washing-up liquid dish soap to remove any deposits. Dry the filter thoroughly with a towel.

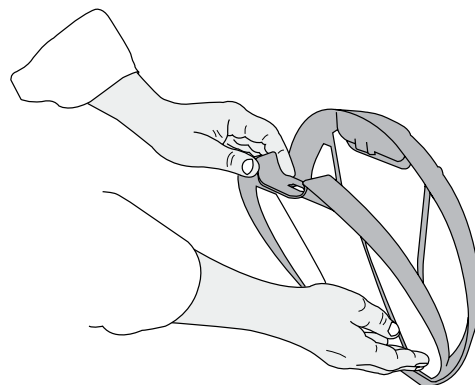

4. Close the lint filter and put it back in the door. Close the lint filter before closing the door.

Cleaning the outside of the machine

Clean the outside of the machine and the program panel with a mild cleaner. Do not use solvents, as these can damage the machine. Do not hose down or spray the machine with water.

NOTE!

Do not allow dust to accumulate around the machine. Keep the area around the tumble dryer clean and cool; dust, heat, and moisture prolong drying times.

Care and maintenance instructions

Cleaning the condenser

The condenser should be cleaned at least three times a year. If you have pets, the condenser must be cleaned more frequently.

1. Turn off the tumble dryer with the main power switch and open the outer door.
2. Remove the Toe kick.

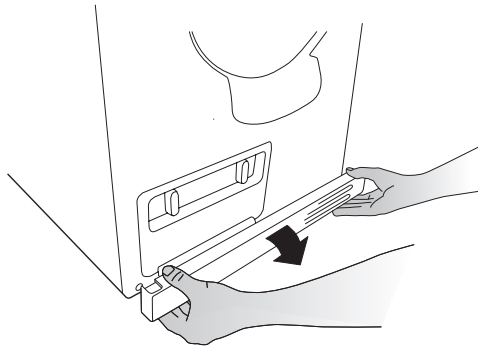

3. Open the condenser panel by turning the two knobs.

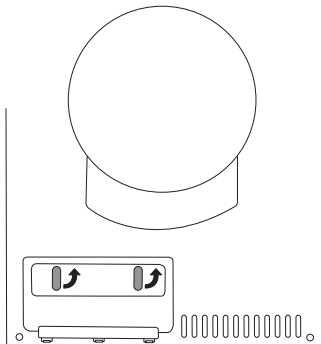

4. Remove the condenser and rinse the ribs clean with a sink spray nozzle or a garden hose with attached spray nozzle. Do not poke around in the rib gaps as you may damage the condenser. Do not use pointed metal objects when cleaning.

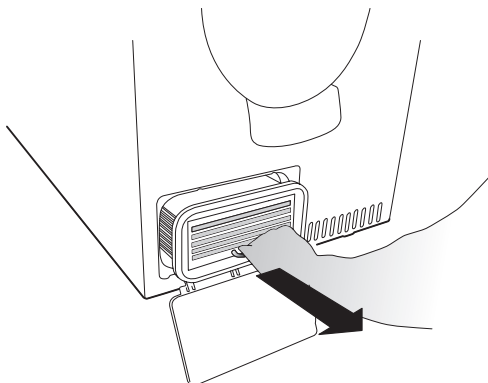

NOTE!

Do not clean the condenser in a dishwasher.

5. Wipe any lint from the channel in front of the condenser and inside the condenser compartment. Use a cotton rag to remove any lint from the drain hole at the front edge of the compartment.

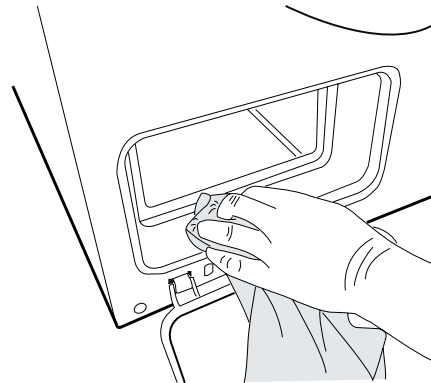

NOTE!

It is quite normal for water to collect in the channel in front of the condenser.

6. Replace the condenser with the handle facing down as illustrated.

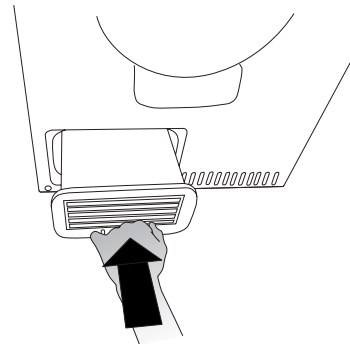

7. Reattach the toe kick.

Troubleshooting

The machine will not start

Check:

- that the door is properly closed.
- that the main power switch is on.
- that the Delayed Start option has not been selected. To cancel Delayed Start, press the Stop button for three seconds.
- that any plug is connected.
- that the house fuses or circuit breaker have not been tripped.
- that the overheating cut-out has not been triggered.

The machine loses all power during a program

The overheating cut-off shuts off the tumble dryer if the temperature is too high, caused by lint clogging the lint filter, for instance.

- Clean the lint filter.
- Check that the condenser is clean. Clean it if necessary. See the Care and maintenance instructions chapter.
- Wait until the machine has cooled, then try starting it. If it still does not start: Call the Customer Care Center.

Drying takes too long

- Check that the lint filter is not blocked. See the Care and maintenance instructions chapter.
- Check that the condenser is not blocked. See the
- Care and maintenance instructions chapter.
- Prolonged drying times may also be due to the tumble dryer being located in a confined area or in a room that is too small, causing the air to become too hot.
- Make sure that the tumble dryer has access to more cold air, open doors and/or windows, for example.

Error messages

If F30 is flashing on the display, the maximum permitted program time has been reached. Check that the lint filter and the condenser are not blocked. See the Care and maintenance instructions chapter.

Technical information

Technical data

Height:	33 1/2" (850 mm)
Width:	23 1/2" (597 mm)
Depth:	23 7/8" (606 mm)
Weight (net):	97 lb (44 kg)
Cylinder volume:	29,6 gal (112 l)
Max. drying capacity:	15 lb (7 kg)
Speed:	50-55 rpm
Rated power:	See serial number tag and rating plate.
Drum material:	Stainless steel
Outer casing material:	Powder-coated and hot-galvanized sheet steel or stainless steel.
Setup	Stacking or freestanding

Service and guarantee

Limited Warranty – Residential Appliances

ASKO Distribution North America, LLC. (“ASKO”) warrants to the original purchaser (the “ASKO Customer”) of the ASKO product (the “ASKO Product”), who purchased the ASKO Product from a distributor, dealer, manufacturer’s representative or other seller who has been authorized by ASKO, that this ASKO Product is free of defects in materials and/or workmanship, subject to the terms and conditions set forth herein. This Limited Warranty covers parts and labor, except as set forth in this Limited Warranty. Service must be provided by an authorized ASKO service company. YOUR SOLE AND EXCLUSIVE REMEDY UNDER THIS LIMITED WARRANTY SHALL BE PRODUCT REPAIR AS PROVIDED HEREIN. This Limited Warranty is valid only when the ASKO Product is used in the country in which it was purchased. Proof of original purchase date is required to obtain service under this Limited Warranty.

Residential ASKO Products Used Exclusively for Household/Personal Purposes:

Two (2) Years limited Warranty – Any warranty service claims for residential ASKO Products must be filed with ASKO within two (2) years from date of purchase. Service will be provided during normal business hours.

Residential ASKO Products Not Used Exclusively for Household/Personal Purposes or used Commercially or used in Marine, Mobile or Aeronautical Applications:

One (1) Year limited Warranty – Any warranty service claims for ASKO Products not used exclusively for household and personal use, or used commercially or used in marine, mobile, or aeronautical applications must be filed with ASKO within one (1) year from date of purchase. Service will be provided during normal business hours.

ITEMS EXCLUDED FROM WARRANTY

This limited warranty does not cover:

1. Replacement parts or repair labor if the ASKO Product is used in a manner that is inconsistent with published user or operator instructions and/or installation instructions.
2. Service calls to correct the installation of the ASKO Product, to instruct you on how to use the ASKO Product, to replace or repair house fuses, or to correct house wiring or plumbing.
3. Consumable items and parts, such as filters.
4. Damage resulting from accident, alteration, misuse, abuse, negligence, fire, flood, acts of God, improper use, improper installation, installation not in accordance with electrical or plumbing codes, or use of products not approved by ASKO, as well as any attempted repair by other than authorized ASKO service companies.
5. Cosmetic damage, including scratches, dents, chips or other damage to the finish of the ASKO Product, unless such damage results from defects in materials or workmanship and is reported to ASKO within 5 days from date of purchase.
6. Pickup and delivery. The ASKO Product is intended to be repaired in your home.
7. Repairs to parts or systems resulting from unauthorized modifications made to the ASKO Product.
8. Expenses for travel and transportation for product service if the ASKO Product is located in a remote area where service by an authorized ASKO service company is not available.
9. The removal and reinstallation of the ASKO Product if it is installed in an inaccessible location or is not installed in accordance with ASKO’s published installation instructions.
10. Replacement parts or repair labor on ASKO Products with original model/serial numbers that have been removed, altered or cannot be easily determined.

Service and guarantee

DISCLAIMER

YOUR SOLE AND EXCLUSIVE REMEDY UNDER THIS LIMITED WARRANTY SHALL BE PRODUCT REPAIR AS PROVIDED HEREIN. EXPRESSLY DISCLAIMED ARE ALL OTHER EXPRESS AND IMPLIED WARRANTIES, INCLUDING ANY IMPLIED WARRANTIES OF MERCHANTABILITY AND FITNESS FOR A PARTICULAR PURPOSE. Some jurisdictions do not allow exclusion or limitations regarding warranty rights. This Limited Warranty gives you specific legal rights and you may have other rights that vary from jurisdiction to jurisdiction. Attempted repair by any person other than an authorized ASKO service company will void this Limited Warranty.

LIMITATION OF LIABILITY

IN NO EVENT SHALL ASKO OR THE MANUFACTURER AND THEIR RESPECTIVE PARENTS, SUBSIDIARIES AND AFFILIATES BE LIABLE FOR CONSEQUENTIAL, INCIDENTAL, EXEMPLARY, PUNITIVE OR SPECIAL DAMAGES. IN NO EVENT SHALL ASKO OR THE MANUFACTURER AND THEIR RESPECTIVE PARENTS, SUBSIDIARIES AND AFFILIATES BE LIABLE FOR DAMAGES OTHER THAN ACTUAL DAMAGES AND IN NO EVENT FOR DAMAGES IN EXCESS OF THE PRICE PAID FOR THE ASKO PRODUCT AS TO WHICH A CLAIM IS MADE. Some jurisdictions do not allow the exclusion or limitation of incidental, consequential or other damages, so these limitations and exclusions may not apply to you. This Limited Warranty gives you specific legal rights. You also may have other rights that vary from jurisdiction to jurisdiction.

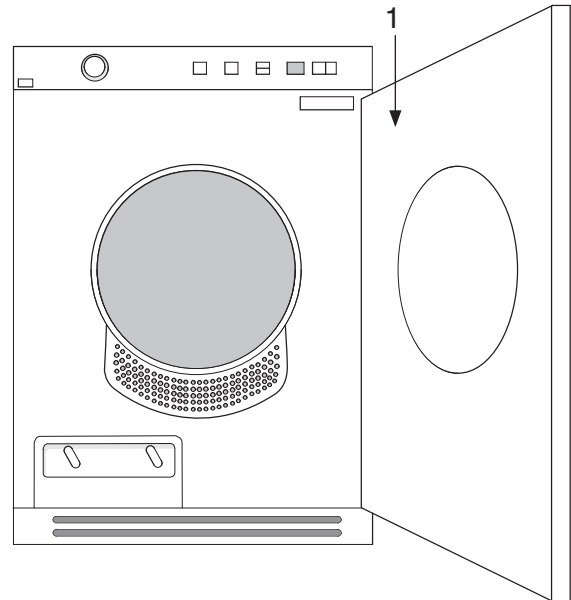

TROUBLESHOOTING & ASKO CUSTOMER CARE

If you think you need repair service, first see the “Troubleshooting” section of the Use & Care Guide. If you are unable to resolve the problem after checking “Troubleshooting,” then additional help can be obtained by calling ASKO Customer Care at 1-800-898-1879. Read the “Troubleshooting” chapter before contacting the Customer Care Center. Make a note of the (1) service number, (2) item number and (3) serial number.

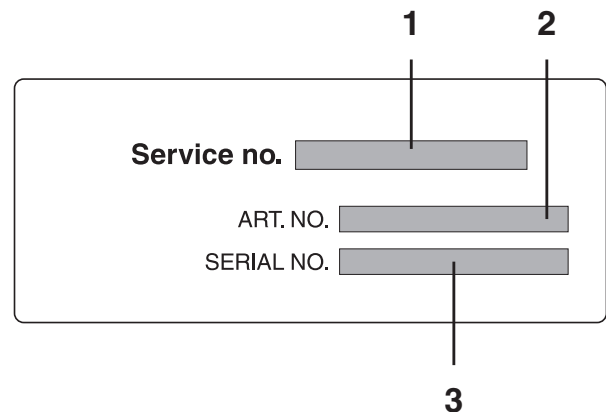

Service and guarantee

NOTE!

Repair or any warranty claim resulting from incorrect connection or use of the dryer shall not be covered by the warranty. In such cases, the costs of repair shall be charged to the user.

SERVICE AFTER EXPIRATION OF LIMITED WARRANTY

For information about obtaining parts and labor after expiration of this Limited Warranty or arising outside the scope of this Limited Warranty, please contact ASKO Customer Care at 1-800-898-1879. After your purchase and prior to first use of the ASKO Product, register your ASKO Product with ASKO by utilizing the address information below. Should you need further assistance as well, contact us at the address information below:

ASKO Distribution North America, LLC
Customer Care Center
PO Box 44848
MADISON WI 53744
1-800- 898-1879
www.askona.com

Installation instructions

WARNING!



WARNING - Risk of fire.

Install the clothes dryer according to the manufacturer's instructions and local codes. To reduce the risk of severe injury or death, follow all installation instructions.

SAVE THESE INSTRUCTIONS FOR FUTURE REFERENCE.

Positioning the tumble dryer

The tumble dryer can be freestanding or stacked. Remember that the tumble dryer produces heat and should therefore not be located in a room that is too small. If the room is very small, drying will take longer due to the limited quantity of air.

NOTE!

Do not install the machine in a room where there is a risk of frost occurring. At temperatures around freezing point the machine may not be able to operate properly.

The room in which the appliance is installed should be adequately ventilated, with temperature between 15°C and 25°C.

WARNING!



- Clothes dryer installation must be performed by a qualified installer.
- For proper ventilation, the machine should not be installed behind a door.
- The tumble dryer's toe kick ventilation must not be blocked by a rug or the like.

NOTE!

If the unit must be installed behind a door, the door should be louvered. (please see door ventilation requirements in the Built-in chapter). To improve ventilation, the door where the tumble dryer is located should be left open when the dryer is in use.

Freestanding

The tumble dryer can be positioned beside the washing machine.

Stacking

The tumble dryer can be placed on top of an ASKO washing machine. Use the two foot cups found in the document bag included with the machine and the two tip guards attached to the bottom of the back of the machine.

How to assemble the stacking kit:

1. Remove the two tip guards from the back of the tumble dryer. Replace the screws that held the tip guards in place.

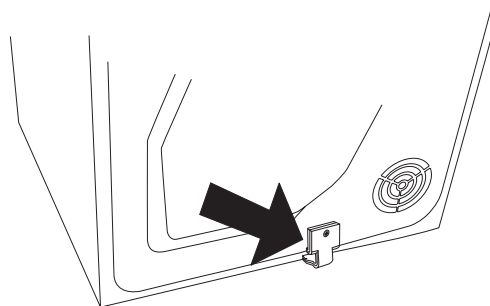

2. Remove the two screws indicated on the back of the washing machine.

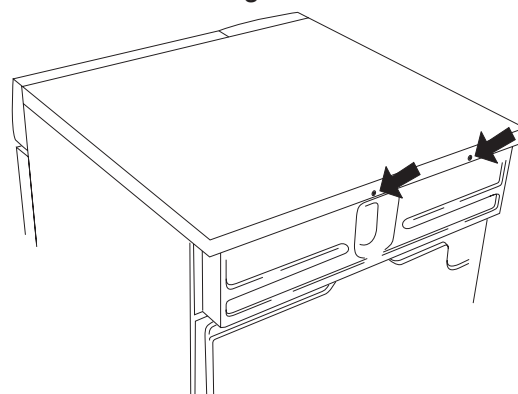

Installation instructions

3. Secure the anti-tip device using the screws as shown in the picture.

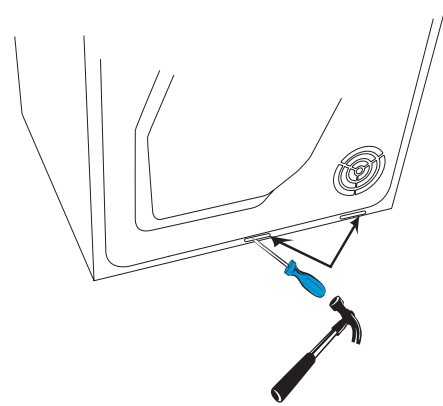
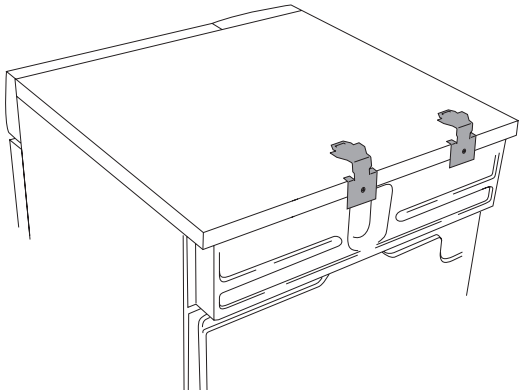

4. Attach the plastic cups for mounting the tumble dryer's front feet to the washing machine's top cover. This is essential, as only when the tumble dryer's feet are resting in the plastic cups can you be sure that the tumble dryer is correctly positioned on the washing machine. Break off tab A on the cup fitted on the right side and tab B on the cup fitted on the left side. Then remove the paper from the self-adhesive surface under the plastic cups.

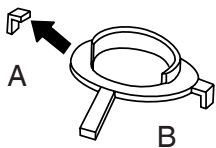

5. Fit the plastic cups so that the "tags" marked with arrows are against the front edge or side edge of the cover and press them firmly onto the cover. Then break off the remaining tabs.

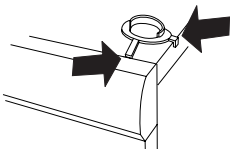

6. Push out the knock-out hole on the back of the tumble dryer (you don't have to completely remove the knockout, just fold it up far enough for the stacking bracket to fit inside the slot) using a hammer and a screwdriver.

7. Push the tumble dryer in under the metal brackets. At the same time keep the front edge raised by 7/16" (10mm) to 7/8" (20mm) .

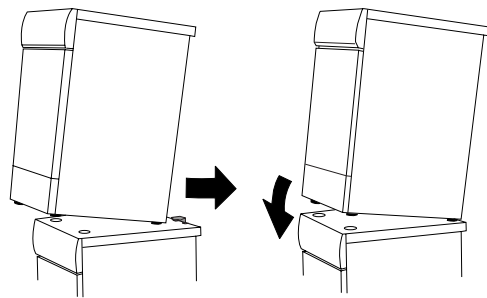

8. Lower the tumble dryer's front feet into the plastic cups and adjust the tumble dryer to ensure it is level.

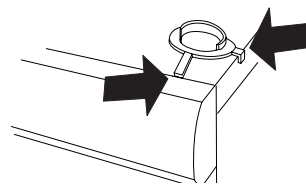

Adjusting the feet

Screw the feet in or out so that the tumble dryer is both stable and level.

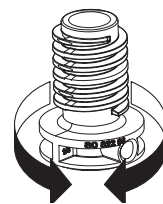

Installation instructions

Built-in

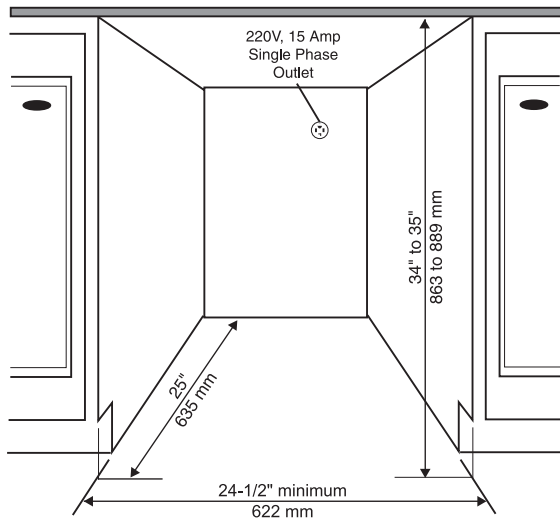

ASKO dryers can be installed beneath a cabinet or worktop with a minimum height of 34" (864 mm). There must be a gap of about 1/2" (12 mm) all around the machine and a minimum gap of 1" (25 mm) between the rear edge of the machine top panel and the back wall. The opening width must be at least 24-1/2" (622 mm). The condensing models work best when they have good air circulation.

Install the dryer so the condensed water will continuously flow into a drain or sink, you will need a drain outlet behind the unit. The maximum drain height is 40" (1016 mm).

NOTE!

The height adjustment for the dryer is 33- 1/2" to 34-1/2" (850 mm to 876 mm). Do not raise it higher than 34-1/2" (876 mm).

NOTE!

It is very important to avoid a buildup of heat.

The warm air which is expelled from the rear of the dryer must be able to dissipate.

Warm air which cannot dissipate could cause a fault.

A buildup of heat could be avoided by:

- Creating a gap for the dryer in the kitchen furniture plinth facing.
 - Creating ventilation gaps in the kitchen unit.
- When build under, drying times may be longer.

NOTE!

The dryer should not be installed next to a refrigeration appliance. The warm air expelled from the rear of the dryer would increase the temperature around the refrigeration appliance heat exchanger causing the compressor to run continuously. If it is not possible to install the dryer anywhere else, then the refrigeration appliance must be sealed off from the dryer.

Installation instructions

Install in a closet

ASKO's front panel controls make it possible to install the washers and dryers in a closet. Make sure there is a $\frac{1}{2}$ " (12 mm) minimum clearance between units and cabinet or wall and a 1" (25 mm) minimum clearance between the rear edge of the machine top panel and the cabinet or wall. To ensure proper ventilation, we recommend louvered doors, particularly for condenser dryers. Otherwise there must be ventilation openings in the door. See illustration for minimum ventilation openings:

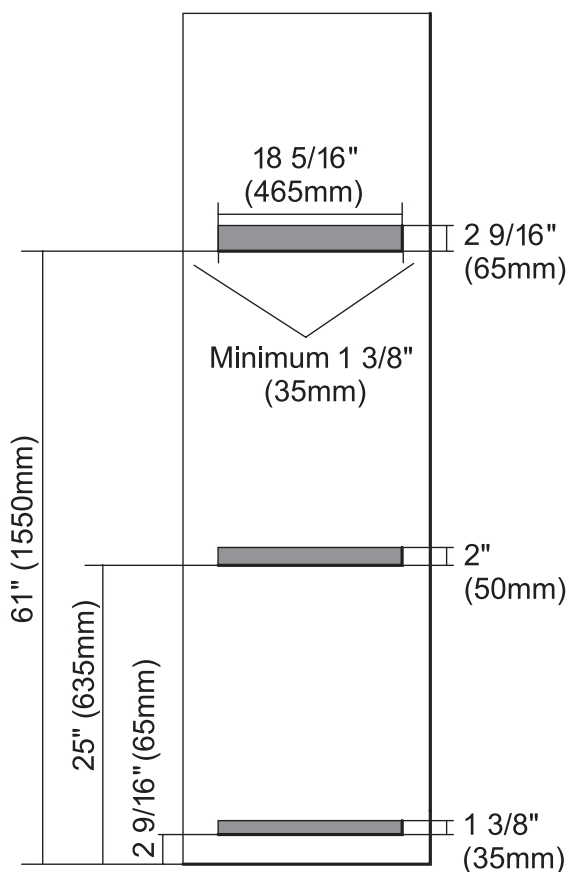

NOTE!

Ensure the dryer door can be opened without hindrance after installation.

NOTE!

The cool air intake panel at the front of the dryer must not be blocked or covered. Doing so could cause a fault.

Condensed water

Install the dryer so the condensed water will continuously flow into a drain or sink. To do this, follow the instructions below:

- 1 Connect the rubber hose supplied with the dryer to the blue nipple.
2. Run the hose to a drain or sink, as illustrated.

NOTE!

The drain hose must not be more than 40" (100 cm) above the floor.

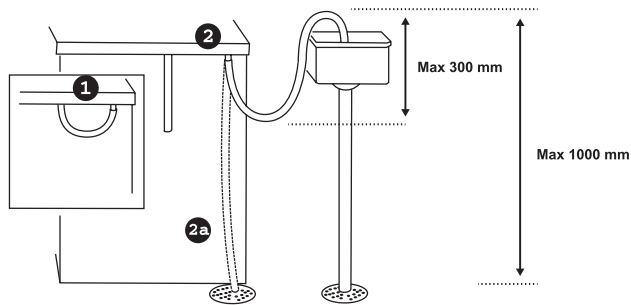

Installation instructions

Electrical installation

WARNING!



The receptacle on the rear of the machine is designed to accommodate ASKO washers ONLY (rated 208–240 V.) To use this receptacle, you must use the ready-fitted plug supplied with the washing machine or an equivalent. ASKO washers rated 208–240 V have two internal fuses of 15 A each. The machine should only be connected to a grounded wall socket.

WARNING!



This appliance must be properly grounded. Refer to the “Important Safety Instructions” for grounding instructions. The power supply cord must be grounded. If the machine is to be used in a wet area, the supply must be protected by a residual current device. Connection to a permanently wired supply point must be made only by a qualified electrician. As supplied: Single-phase, 230 V, 60 Hz, 3000W heater rating 30 A circuit required.

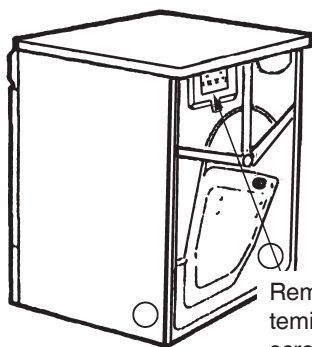

Remove cover to access terminal box. (Requires Torx screwdriver.)

Electrical Connections

WARNING!



Read the Electrical requirements and grounding instructions before connecting the tumble dryer.

Electric models of the dryer are manufactured for a 3-wire connection system. The dryer frame is grounded by a link to the neutral conductor on the dryer terminal block. If local codes do not permit grounding through the neutral, the grounding link from the terminal block must be removed and a separate ground wire must be used.

Only a 4-conductor cord shall be used when the appliance is installed in a location where grounding through the neutral conductor is prohibited. Grounding through the neutral conductor is prohibited for new branch-circuit installations, mobile homes, recreational vehicles, and areas where local codes prohibit grounding through the neutral conductors. The grounding link on the dryer must be removed for all 4-wire installations.

These Electrical Connection instructions provide for installing the dryer in the following situations:

3-wire connection where local codes permit grounding through the neutral. 3-wire connection plus separate grounding connector where local codes do not permit grounding through the neutral.

4-wire connection.

Each of the above connections can be made with an approved power supply cord or by direct wiring. Each connection instruction identifies the appropriate Power Supply Cord and covers requirements for direct wiring.

NOTE!

In Canada, the dryer is delivered ready-fitted with a four-prong plug intended for connection to a single-phase supply.

Installation instructions

Connecting a 3-wire Power Cord

WARNING!



Before starting this procedure, be sure the power is turned off at the breaker/fuse box.

3-Wire Cord

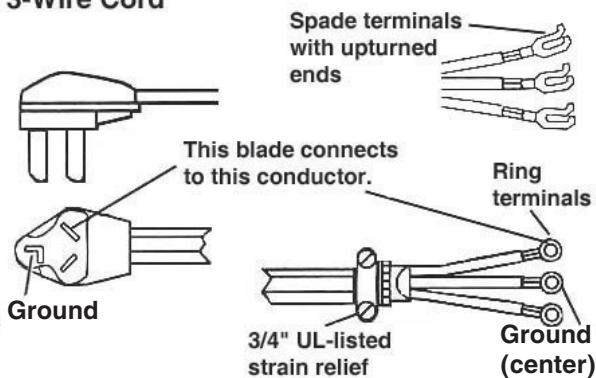

Power Supply Cord

You will need a 3-wire power supply cord with three No. 10 copper wires and a matching 3-wire receptacle of NEMA Type 10-30R, as illustrated below:

To connect a 3-wire power cord to the dryer, follow the steps below.

NOTE!

The numbers in the illustration correlate to the step numbers.

1. Turn the power off at the breaker or fuse box.
2. Remove terminal block cover.
3. Use the strain relief attached below the terminal block opening.
4. Loosen or remove center terminal block screw.

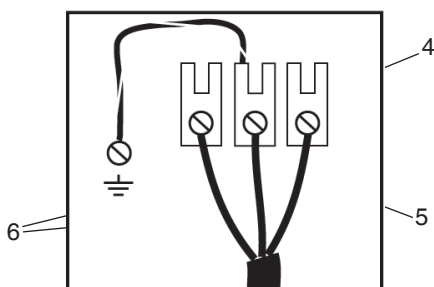

5. Connect ground (center) wire of power supply cord to the center, silver-colored terminal screw. Tighten screw.
6. Connect the other wires to outer screws.
7. Tighten the strain relief screws.
8. Replace terminal block cover on back of dryer.
9. Plug dryer into wall receptacle.
10. Turn power on at breaker/fuse box.

Connecting a 4-wire Power Cord

WARNING!



Before starting this procedure, be sure the power is turned off at the breaker/fuse box.

4-WIRE CORD

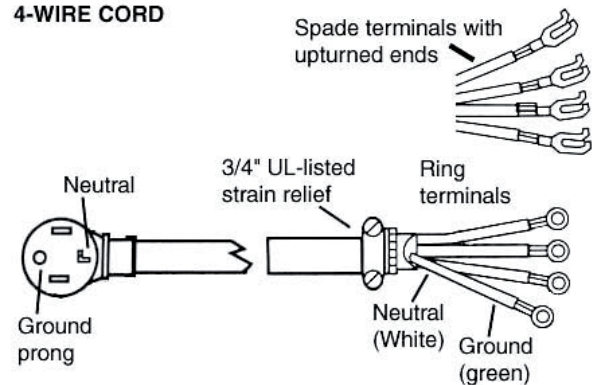

Power Supply Cord

You will need a 4-wire power supply cord with four No. 10 copper wires and a matching 4-wire receptacle of NEMA Type 14-30R, as illustrated below.

The fourth wire must be identified with a white cover and the ground conductor by a green cover.

To connect a 4-wire power cord to the dryer, follow the steps below.

NOTE!

The numbers in the illustration correlate to the step numbers.

1. Turn the power off at the breaker/fuse box.
2. Remove terminal block cover.
3. Use the strain relief attached below the

Installation instructions

terminal block opening.

4. Remove center terminal block screw.

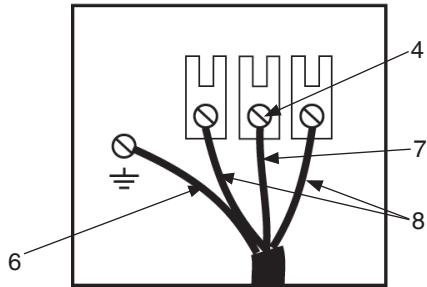

5. Remove ground wire (green with yellow stripes) from external ground connector screw and remove from center terminal block.
6. Connect ground (green) wire of cord to external ground conductor screw.
7. Connect neutral (white) wire of cord under center screw of terminal block.
8. Connect the other wires to outer screws.
9. Tighten the strain relief screws.
10. Replace terminal box cover on back of dryer.
11. Plug dryer into wall receptacle.
12. Turn power on at breaker/fuse box.

Reversing the door

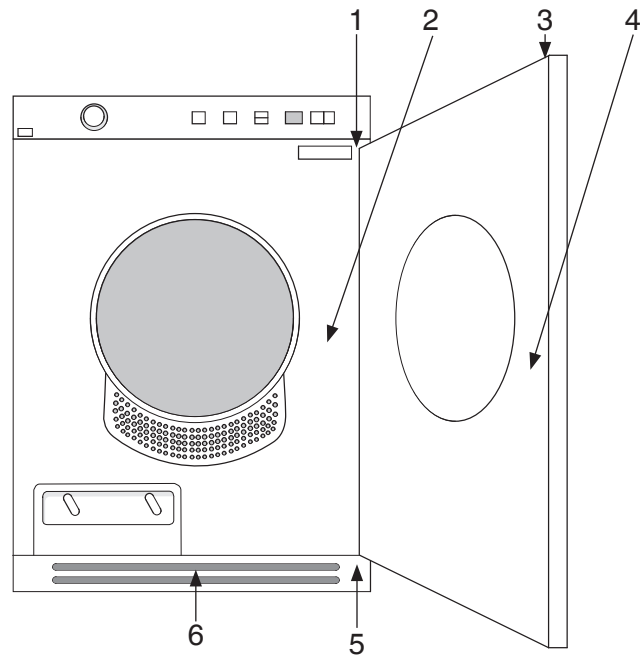

- 1. Hinge pins (top and bottom)
- 2. Cover plate
- 3. Plastic plugs (on the upper and lower edges)
- 4. Lock hook
- 5. Hinges (left + right side)
- 6. Toe kick

Reversing the door

You can choose whether the door is hung on the right or the left.

Follow these instructions:

1. Remove the Toe kick.
2. Remove the hinge (two screws).
6. Move the plastic plugs on the upper and lower edges of the door. Use a flat screwdriver to remove the plugs.
7. Refit the door by loosening the hinge screws slightly, affixing the door, and closing it. Tighten the hinges. Replace the Toe kick.

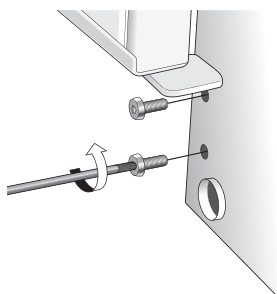

3. Lift the door up and remove it. Support the door while doing this.
4. Remove both door pins (top and bottom). Fit them on the other side of the machine. Replace the hinge.

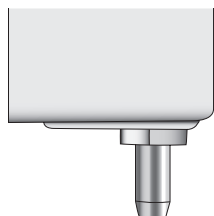

5. Loosen and remove the catch (lift up and pull out) and the cover plate on the door and the machine. Switch the catch and the cover plate.

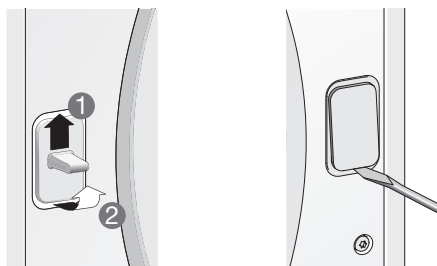

Notes

Notes

QUICK GUIDE

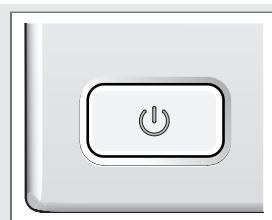

1.

TURN ON THE MAIN POWER SWITCH

Load the garments. Close the door.



2.

SELECT A PROGRAM AND ANY OPTIONS

Turn the program selector to the desired program.



3.

PRESS THE START BUTTON

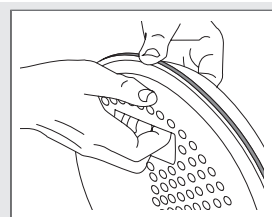

4.

DRYING PROGRAM FINISHED

The text "End" is shown on the display for 2 minutes.

The machine then turns off.

Clean the lint filter after each load.

Close the door.

We reserve the right to make changes.

ASKO

Swedish quality since 1950

www.askona.com



TD70.1
T754C W US/CA



461748



MIX
Paper from
responsible sources
FSC® C114278

en (12-14)