

## 1000 CFM Inline Blower VT11010P



### Product Features

To minimize noise in the kitchen, these blowers are mounted along the duct line anywhere between the kitchen and the exterior wall.

Use the EXTNCB25 Blower Cable Connection Accessory for install with select hoods. Separate purchase required.



Notes: Please refer to installation instructions. Installation instructions are available at [www.thermador.com](http://www.thermador.com). Specifications are correct at the time of printing. Thermador reserves the right to change product specifications and design at any time, without notice.

1 800 735 4328 | [WWW.THERMADOR.COM](http://WWW.THERMADOR.COM) | 1901 Main Street, Suite 600 Irvine, CA 92614

©2018 BSH HOME APPLIANCES CORPORATION, ALL RIGHTS RESERVED LITHO DATE: 09/2018

## 1000 CFM Inline Blower VT11010P

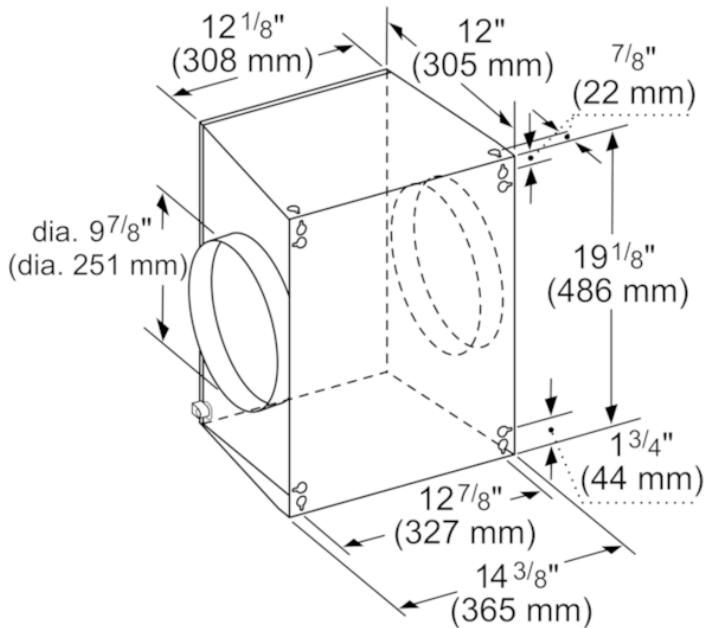

measurements in inches (mm)

### Product Features

Product group	Accessory
Brand	Thermador
SKU	VT11010P
Internal article number	VT11010P
EAN code	825225918899
Product packaging dimensions (HxWxD) (in)	17 11/16" x 23 5/8" x 26 3/4"
Net weight (lbs)	38
Gross weight (lbs)	41
UPC code	825225918899
Name of product image	MCSA036808_VT11010D_def.jpg

### Technical Specification

Notes: Please refer to installation instructions. Installation instructions are available at [www.thermador.com](http://www.thermador.com). Specifications are correct at the time of printing. Thermador reserves the right to change product specifications and design at any time, without notice.

1 800 735 4328 | [WWW.THERMADOR.COM](http://WWW.THERMADOR.COM) | 1901 Main Street, Suite 600 Irvine, CA 92614

©2018 BSH HOME APPLIANCES CORPORATION, ALL RIGHTS RESERVED LITHO DATE: 09/2018