

SHARP®

FP-F60U-W

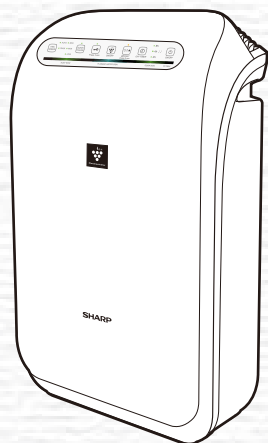

Device of this mark is a trademark of Sharp Corporation. "Plasmacluster" and "Device of a cluster of grapes" are registered trademarks of Sharp Corporation in Japan, USA and elsewhere.



This product earned the ENERGY STAR by meeting strict energy efficiency guidelines set by the US EPA. US EPA does not endorse any manufacturer claims of healthier indoor air from the use of this product.

The energy efficiency of this ENERGY STAR qualified model is measured based on a ratio between the model's CADR for Dust and the electrical energy it consumes, or CADR/Watt.

Ce produit a le droit de porter la marque ENERGY STAR après avoir répondu à des critères stricts en ce qui concerne l'efficacité énergétique, tels qu'établis par l'agence EPA aux É-U. L'agence EPA aux É-U n'appuie aucunement les témoignages publicitaires du fabricant indiquant que ce produit rend l'air intérieur des locaux plus sain.

L'efficacité énergétique de ce modèle, qui bénéficie de la reconnaissance ENERGY STAR, est mesurée par le rapport entre le DAP (débit d'air purifié) du modèle et l'énergie électrique qu'il consomme, soit le rapport DAP/Watt.

AIR PURIFIER OPERATION MANUAL

Purificateur d'air à fonction MANUEL D'UTILISATION

PURIFICADOR DE AIRE MANUAL DE OPERACIÓN

ENGLISH

FRANÇAIS

ESPAÑOL

Please read before operating your new Air Purifier

The air purifier draws in room air from the air intake, passes the air through a Pre-Filter, a Deodorizing filter and a True HEPA filter inside of the unit, then dis-charges the air through the air outlet. The True HEPA filter can remove 99.97% of dust particles as small as 0.3 microns that pass through the filter and also helps absorb odors. The Deodorizing filter gradually absorbs odors as they pass through filter.the

Some odors absorbed by the filters may break down over time, resulting in additional odor. Depending on the usage environment, especially when the product is used in extreme environments (significantly more severe than normal household use), this odor may become strong in a shorter period than expected. If the odor persists, the filters should be replaced.

NOTE

- The air purifier is designed to remove air-suspended dust and odor, but not harmful gases (for example, carbon monoxide contained in cigarette smoke). If the source of the odor still exists, the air purifier may not completely remove the odor.

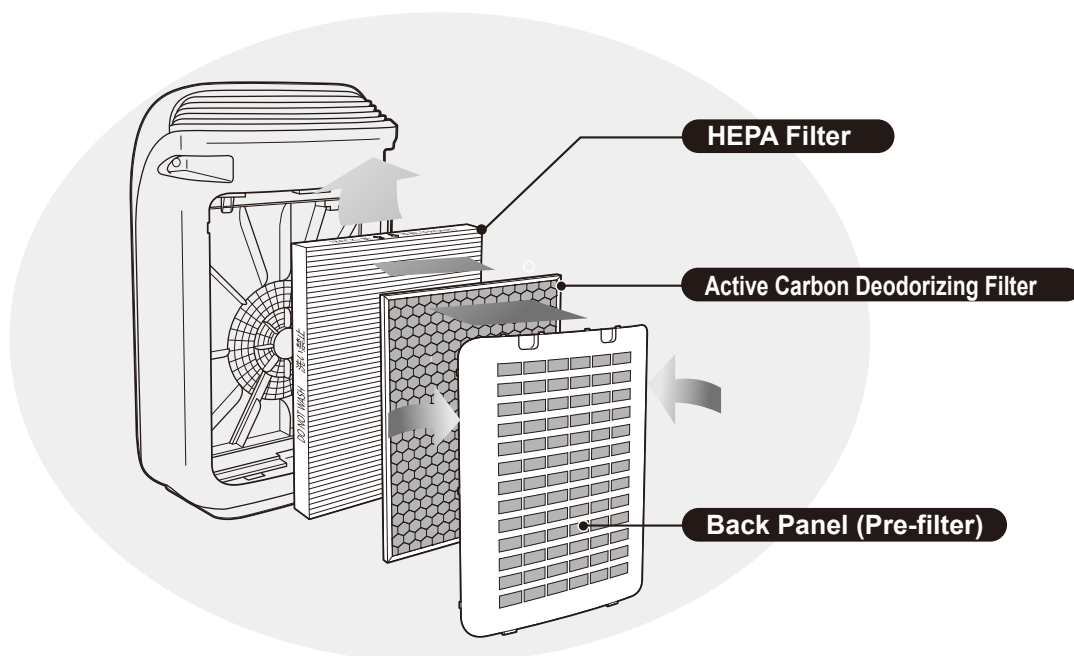

FEATURES

Unique Combination of Air Treatment Technologies

Triple Filtration System + Plasmacluster Ion.

TRAPS DUST*

Washable pre-filter traps dust and other large airborne particles.

DECREASES ODORS

Deodorizing filter absorbs many common household odors.

REDUCES POLLEN & MOLD*

True HEPA filter traps 99.97% of particles as small as 0.3 microns.

FRESHENS

Plasmacluster refreshes the air similar to the way nature cleans the environment by emitting a balance of positive and negative ions.

*When air is drawn through the filter system.

Declaration of Conformity

SHARP AIR PURIFIER FP-F60U

This device complies with Part 15 of FCC rules.

Responsible Party:

SHARP ELECTRONICS CORPORATION
100 Paragon Drive, Suite #100,
Montvale, NJ 07645, U.S.A.

Declaration of Conformity

SHARP AIR PURIFIER FP-F60U

This ISM device complies with Canadian ICES-3(B)

Responsible Party:

SHARP ELECTRONICS OF CANADA LTD.
335 Britannia Road East Mississauga, Ontario
L4Z 1W9 Canada
TEL: (905) 568-7140

CONTENTS

FOR CUSTOMER ASSISTANCE(U.S)	E-2
CONSUMER LIMITED WARRANTY(U.S).....	E-3
FOR CUSTOMER ASSISTANCE(CANADA)	E-4
LIMITED WARRANTY(CANADA)	E-5
IMPORTANT SAFETY INSTRUCTIONS ...	E-6
• WARNING	E-6
• CAUTIONS CONCERNING OPERATION ..	E-7
• INSTALLATION GUIDELINES.....	E-7
• FILTER GUIDELINES	E-7
PART NAMES	E-8
• FRONT VIEW	E-8
• BACK VIEW	E-8
• CONTROL PANEL	E-9
PREPARATION FOR USE	E-10
• FILTER INSTALLATION	E-10
OPERATION	E-11
• CLEAN AIR MODE	E-11
• QUICK CLEAN MODE	E-11
• FAN SPEED Button	E-12
• Plasmacluster ON/OFF Button	E-12
• CHILD LOCK Button	E-12
• POWER ON/OFF Button	E-12
• LIGHT CONTROL BRIGHT/DIM/OFF Button..	E-13
• OFF TIMER Button	E-13
• ADJUSTMENT OF SENSOR DETECTION SENSITIVITY..	E-13
CARE AND MAINTENANCE	E-14
• REAR PANEL (PRE-FILTER)	E-14
• MAIN UNIT	E-15
• HEPA FILTER, ACTIVE CARBON DEODORIZING FILTER	E-15
• FILTER REPLACEMENT GUIDELINES.....	E-16
TROUBLESHOOTING	E-17
SPECIFICATIONS.....	E-19

Thank you for purchasing this SHARP Air Purifier. Please read this manual carefully before using the air purifier. After reading, keep the manual in a convenient location for future reference.

FOR CUSTOMER ASSISTANCE (the United States)

To aid in answering questions if you call for service or for reporting loss or theft, please use the space below to record the model and serial number located on the back of the unit.

MODEL NUMBER

SERIAL NUMBER

DATE OF PURCHASE

Dealer Name

Address

City

State

Zip

Telephone

TO PHONE: Dial 1-800-BE-SHARP (237-4277) for:
SERVICE (for your nearest Sharp Authorized Servicer)
PARTS (for your Authorized Parts Distributor)
ACCESSORIES
ADDITIONAL CUSTOMER INFORMATION

TO WRITE: For service problems, warranty information, missing items and other assistance:
Sharp Electronics Corporation
Customer Assistance Center
Sharp Plaza Blvd.
Memphis, TN 38193

TO ACCESS OUR WEB SITE: www.sharpusa.com

Please provide the following information when you write or call: model number, serial number, date of purchase, your complete mailing address (including zip code), your daytime telephone number (including area code) and description of the problem.

CONSUMER LIMITED WARRANTY

ENGLISH

CONSUMER LIMITED WARRANTY FOR U.S. USERS

SHARP ELECTRONICS CORPORATION warrants to the first consumer purchaser that this Sharp brand product (the "Product"), when shipped in its original container, will be free from defective workmanship and materials, and agrees that it will, at its option, either repair the defect or replace the defective Product or part thereof with a new or remanufactured equivalent at no charge to the purchaser for parts or labor for the period(s) set forth below.

This warranty does not apply to any appearance items of the Product nor to the additional excluded item(s) set forth below nor to any Product the exterior of which has been damaged or defaced, which has been subjected to improper voltage or other misuse, abnormal service or handling, or which has been altered or modified in design or construction.

In order to enforce the rights under this limited warranty, the purchaser should follow the steps set forth below and provide proof of purchase to the servicer.

The limited warranty described herein is in addition to whatever implied warranties may be granted to purchasers by law. ALL IMPLIED WARRANTIES INCLUDING THE WARRANTIES OF MERCHANTABILITY AND FITNESS FOR USE ARE LIMITED TO THE PERIOD(S) FROM THE DATE OF PURCHASE SET FORTH BELOW. Some states do not allow limitations on how long an implied warranty lasts, so the above limitation may not apply to you.

Neither the sales personnel of the seller nor any other person is authorized to make any warranties other than those described herein, or to extend the duration of any warranties beyond the time period described herein on behalf of Sharp.

The warranties described herein shall be the sole and exclusive warranties granted by Sharp and shall be the sole and exclusive remedy available to the purchaser. Correction of defects, in the manner and for the period of time described herein, shall constitute complete fulfillment of all liabilities and responsibilities of Sharp to the purchaser with respect to the Product, and shall constitute full satisfaction of all claims, whether based on contract, negligence, strict liability or otherwise. In no event shall Sharp be liable, or in any way responsible, for any damages or defects in the Product which were caused by repairs or attempted repairs performed by anyone other than an authorized servicer. Nor shall Sharp be liable or in any way responsible for any incidental or consequential economic or property damage. Some states do not allow the exclusion of incidental or consequential damages, so the above exclusion may not apply to you.

THIS WARRANTY GIVES YOU SPECIFIC LEGAL RIGHTS. YOU MAY ALSO HAVE OTHER RIGHTS WHICH VARY FROM STATE TO STATE.

Your Product Model Number & Description:

FP-F60U-W Air Purifier. Be sure to have this information available when you need service for your Product.

Warranty Period for this Product:

One (1) year parts and labor from date of purchase.

Additional Item(s) Excluded From Warranty Coverage:

Appearance items of the Product, filters, accessories, or any printed materials. Product which has been used for rental and/or commercial purposes.

Where to Obtain Service:

From a Sharp Authorized Servicer located in the United States. To find the location of the nearest Sharp Authorized Servicer, call Sharp Toll Free at 1-800-BE-SHARP.

What to Do to Obtain Service:

Ship prepaid or carry in your Product to a Sharp Authorized Servicer. Be sure to have Proof of Purchase available. If you ship the Product, be sure it is insured and packaged securely.

TO OBTAIN SUPPLY, ACCESSORY OR PRODUCT INFORMATION, CALL 1-800-BE-SHARP, OR VISIT OUR WEBSITE AT www.sharppusa.com

SHARP®

SHARP ELECTRONICS CORPORATION

100 Paragon Drive, Suite #100, Montvale, NJ 07645, U.S.A.

FOR CUSTOMER ASSISTANCE (Canada)

To aid in answering questions if you call for service or for reporting loss or theft, please use the space below to record the model and serial number located on the back side of the unit.

MODEL NUMBER

SERIAL NUMBER

DATE OF PURCHASE

Dealer Name

Address

City

Province

Postal Code

Telephone

TO PHONE: Dial 1-905-568-7140 for:

SERVICE (for your nearest Sharp Authorized Servicer)

PARTS (for your Authorized Parts Distributor)

ACCESSORIES

ADDITIONAL CUSTOMER INFORMATION

TO WRITE: For service problems, warranty information, missing items and other assistance:

Sharp Electronics of Canada Ltd.

Customer Care

335 Britannia Road East

Mississauga, Ontario L4Z 1W9

TO ACCESS OUR WEB SITE: www.sharp.ca

Please provide the following information when you write or call: model number, serial number, date of purchase, your complete mailing address (including Postal Code), your daytime telephone number (including area code) and description of the problem.

SHARP®

LIMITED WARRANTY

Consumer Electronics Products Congratulations on your purchase!

Sharp Electronics of Canada Ltd. ("Sharp") warrants to the first purchaser for this Sharp brand product ("Product"), when shipped in its original container and sold or distributed in Canada by Sharp or by an authorized Sharp dealer, and Product was not sold "as is" or "sales final" that the Product will during the applicable warranty period, be free from defects in material and workmanship, and will within the applicable warranty period, either repair the defective Product or provide the first purchaser a replacement of the defective Product.

Conditions: This limited warranty shall not apply to:

- (a) Any defects caused or repairs required as a result of abusive operation, negligence, accident, improper installation or inappropriate use as outlined in the owner's manual or other applicable Product documentation.
- (b) Any defects caused or repairs required as a result of any Product that has been tampered with, modified, adjusted or repaired by any person other than Sharp, a Sharp authorized service centre or a Sharp authorized servicing dealer.
- (c) Any defects caused or repairs required as a result of the use of the Product with items not specified or approved by Sharp, including but not limited to chemical cleaning agents.
- (d) Any replacement of accessories required through normal use of the Product, including but not limited to, earphones, remote controls, AC adapters, batteries, temperature probe, trays, filters, belts, ribbons, cables and paper.
- (e) Any cosmetic damage to the Product surface or exterior that has been defaced or caused by normal wear and tear.
- (f) Any defects caused or repairs required as a result of damage caused by any external or environmental conditions, including but not limited to, transmission line/power line voltage or liquid spillage or acts of God.
- (g) If the serial number or model number affixed to Product has been removed, defaced, changed, altered or tampered with.
- (h) This limited warranty will not apply if the Product has been used or is being used in a commercial setting or application; this warranty is meant solely for the non-commercial, household use of the Product by consumers in their home or residence.
- (i) Any installation, delivery, setup and/or programming charges
- (j) The removal and reinstallation of Over-The-Range Microwave or Microwave Drawer if it is installed in an inaccessible location or requiring removal of cupboards, handles or other cosmetic parts, or is not installed in accordance with installation instructions included with Product.

How to get service: Warranty service may be obtained upon delivery of the Product, together with proof of purchase (including date of purchase) and a copy of this limited warranty statement, to an authorized Sharp service centre or an authorized Sharp servicing dealer. In home warranty service will be carried out to locations accessible by on-road service vehicle and within 50 km of an authorized Sharp service centre on any Sharp Television with the repair at the service's facility. No other person (including any Sharp dealer or service centre) is authorized to extend, enlarge or transfer this warranty on behalf of Sharp. The purchaser will be responsible for any and all removal, reinstallation, transportation and insurance costs incurred with exception for Over-The-Range Microwave Oven or Microwave Drawer Oven whereby Sharp will be responsible for the removal and reinstallation.

The express warranties in this limited warranty are, except for consumer purchasers domiciled in Quebec, in lieu of and, except to the extent prohibited by applicable law, Sharp disclaims all other warranties and conditions, express or implied, whether arising by law, statute, by course of dealing or usage of trade, including, without limitation, implied warranties or conditions of merchantability and/or quality, fitness for a particular use or purpose, and/or non-infringement. **Limitations** (not applicable to consumer purchasers domiciled in Quebec to the extent prohibited under Quebec law): (a) Sharp shall not be liable for any incidental, special, consequential, economic, exemplary or indirect damages of any kind or nature (including lost profits or damages for loss of time or loss of use or loss of data) arising from or in any connection with the use or performance of a Product or a failure of a Product, even if Sharp is aware of or has been advised of the possibility of such damages; (b) the remedies described in this limited warranty constitute complete fulfillment of all obligations and responsibilities of Sharp to the purchaser with respect to the Product and shall constitute full satisfaction of all claims, whether based on contract, negligence, strict liability or otherwise. Some provinces may not allow the exclusion or limitation of certain damages, or limits on the duration or voiding of implied warranties or conditions; in such provinces, the exclusions and limits herein may not apply. This limited warranty is, except for consumer purchasers domiciled in Quebec, governed by the laws of the Province in Canada in which the purchaser has purchased the Product. For consumer purchasers domiciled in Quebec this limited warranty is governed by the laws of Quebec.

WARRANTY PERIODS (calculated from the date of original purchase): Parts & Labour (exceptions noted)

Audio Product	1 year	
Blu-Ray Product	1 year	
LCD/LED TV	1 year	
Microwave Oven	1 year	(magnetron - 4 additional years)
Air Purifier	1 year	
3D Glasses	1 year	
Wireless LAN Adapter	1 year	
Small home appliances	1 year	

To obtain the name and address of the nearest Authorized Sharp Service Centre or Dealer, or for more information on this Limited Warranty, Sharp Extended Warranty Offers, Sharp Canada Products or Accessory Sales, please contact Sharp:

- By writing to Sharp Electronics Of Canada Ltd. at 335 Britannia Road East Mississauga, Ontario L4Z 1W9
- Calling: at 905-568-7140
- Visiting our Web site: www.sharp.ca

THIS LIMITED WARRANTY IS VALID ONLY IN CANADA

IMPORTANT SAFETY INSTRUCTIONS

When using electrical appliances, basic safety precautions should be followed, including the following:

WARNING - To reduce the risk of electrical shock, fire or injury to persons:

- Read all instructions before using the unit.
- Use only a 120 volt outlet.
- The air purifier has a polarized plug (one blade is wider than the other). This plug will fit in a polarized outlet only one way. If the plug does not fit into the outlet, reverse it. If it still does not fit, contact a qualified electrician or service person.
- **Do not use the unit if the power cord or plug is damaged or the connection to the wall outlet is loosened.**
- Periodically remove dust from the plug.
- **Do not insert fingers or foreign objects into the air intake or air outlet.**
- **When removing the power plug, always hold the plug and never pull on the cord.** Electrical shock and/or fire from a short circuit may occur as a result.
- **Do not remove the plug when your hands are wet.**
- **Do not use this unit near gas appliances or fireplaces.**
- **If the power cord is damaged, it must be replaced by the manufacturer, its service agent, a Sharp Authorized Service Center or similarly qualified person in order to avoid a hazard.**
- Do not operate when using aerosol insecticides or in rooms where there is oily residue, incense, sparks from lit cigarettes, chemical fumes in the air, or in locations where the unit may get wet, such as a bathroom.
- Be cautious when cleaning the unit. Strong corrosive cleansers may damage the exterior.
- Only a Sharp Authorized Service Center should service this air purifier. Contact the nearest Service Center for any problems, adjustments, or repairs.

NOTE - Radio or TV Interference

If this air purifier should cause interference to radio or television reception, try to correct the interference by one or more of the following measures:

- Reorient or relocate the receiving antenna.
- Increase the separation distance between the unit and radio/TV receiver.
- Connect the equipment into an outlet on a circuit different from that to which the receiver is connected.
- Consult the dealer or an experienced radio/TV technician for help.

This product fulfils the requirement of the International standard CISPR 11.

In conformity with this standard, this product is classified as group 2 class B equipment.

Group 2 means that the equipment intentionally generates radio-frequency in the form of electromagnetic radiation for electro-discharge machining equipment.

Class B equipment means that the equipment suitable to be used in domestic establishments.

This product complies with the maximum allowable concentration of ozone of 0.050 parts per million by volume (ppmv) in a 24-hour period. The Health Canada Guideline 2010 recommends that the maximum exposure limit, based on an averaging time of 8 hours, is 0.020 ppmv or less when tested in a sealed, controlled room approximately 30 m³.

CAUTIONS CONCERNING OPERATION

- Do not block the intake and/or air outlet.
- Do not use the unit near or on hot objects, such as stoves or heaters or where it may come into contact with steam.
- Always operate the unit in an upright position.
- **Always hold the handles on both sides of the unit when moving it.**
Holding the back panel when carrying may cause it to detach, thus dropping the unit and resulting in bodily injury.
- **Do not operate the unit without the filters properly installed.**
- **Do not wash and reuse the True HEPA filter and Deodorizing filter.**
Washing will not improve filter performance, it may cause electric shock or malfunction.
- **Clean the exterior with a soft cloth only.**
Do not use volatile fluids and/or detergents.
The unit surface may be damaged or cracked.
In addition, the sensors may malfunction as a result.
- To reduce the risk of electric shock, this equipment has a polarized plug (one blade is wider than the other). This plug will fit in a polarized outlet only one way. If the plug does not fit fully in the outlet, reverse the plug. If it still does not fit, contact qualified personnel to install the proper outlet.
Do not alter the plug in any way.
- **Keep the unit away from water.**

INSTALLATION GUIDELINES

- **During the operation of the product, please place the unit at least 6.5ft. (2m) away from equipment utilizing electrical waves such as televisions, radios or wave clocks.**
- **Avoid a location where the sensor is exposed to direct breeze or draft.**
The unit may not operate properly.
- **Avoid use in locations where furniture, fabrics or other items may come in contact with and restrict the air intake and/or air outlet.**
- **Avoid use in locations where the unit is exposed to condensation or rapid temperature changes. (Use under appropriate conditions between 41 - 95°F (5 - 35°C) in the room.)**
(If it is unavoidable please allow unit to stand for 1 hour before switching on.)
- **Place on a stable surface with sufficient air circulation.**
When placing the unit on a heavily carpeted area, the unit may vibrate slightly.
- **Avoid use in locations where grease or oily smoke is generated.** (such as in a kitchen, etc.)
The unit surface may crack or the sensor may malfunction as a result.
- **Place the unit about 1 ft. (30 cm) away from the wall in order to ensure proper airflow.**
Placing the purifier 1ft. or more from wall will reduce dust buildup on wall surface.

FILTER GUIDELINES

- Follow the instructions in this manual for correct care and maintenance of the filters. Use only filters designed for this product.

PART NAMES

FRONT VIEW

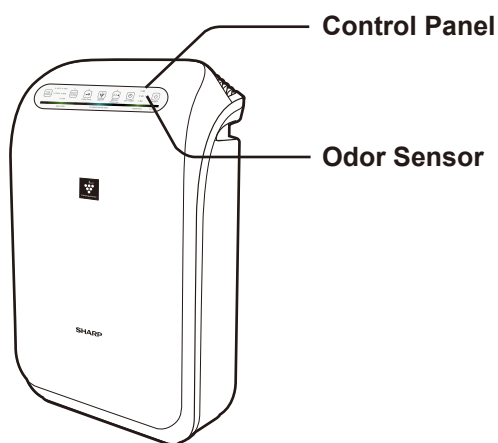

BACK VIEW

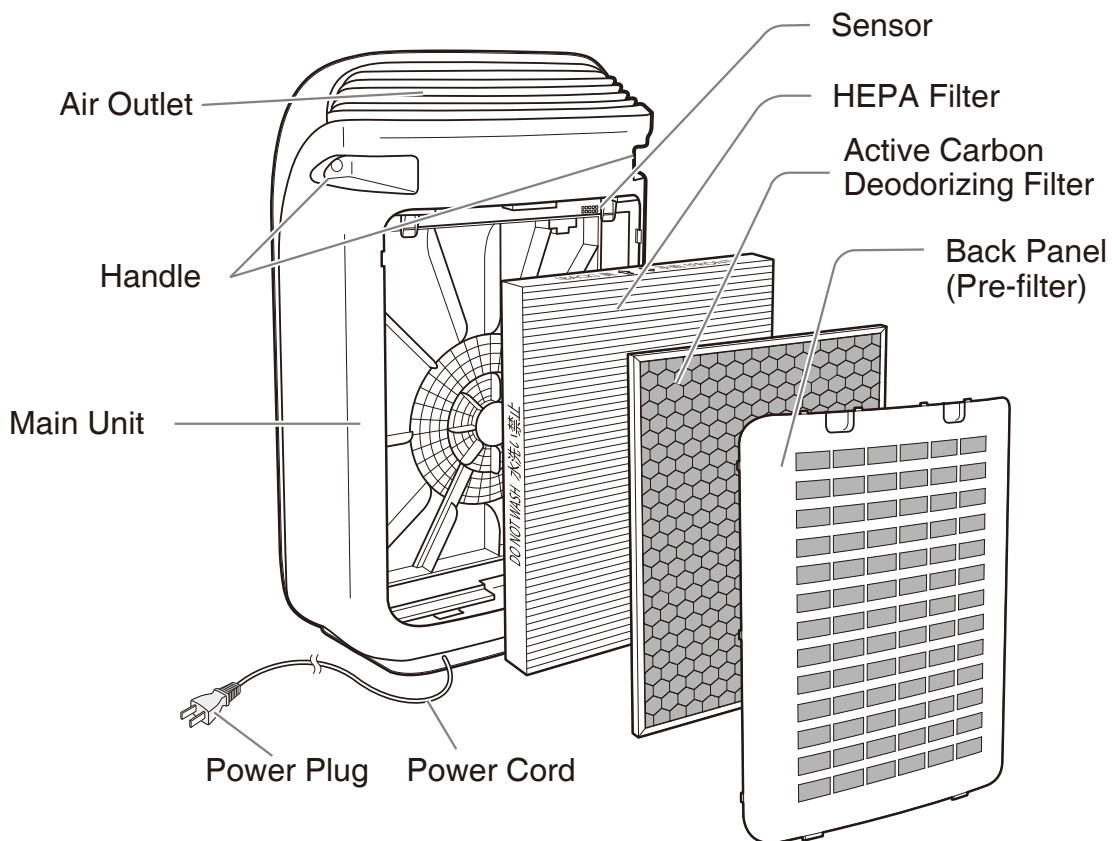

CONTROL PANEL

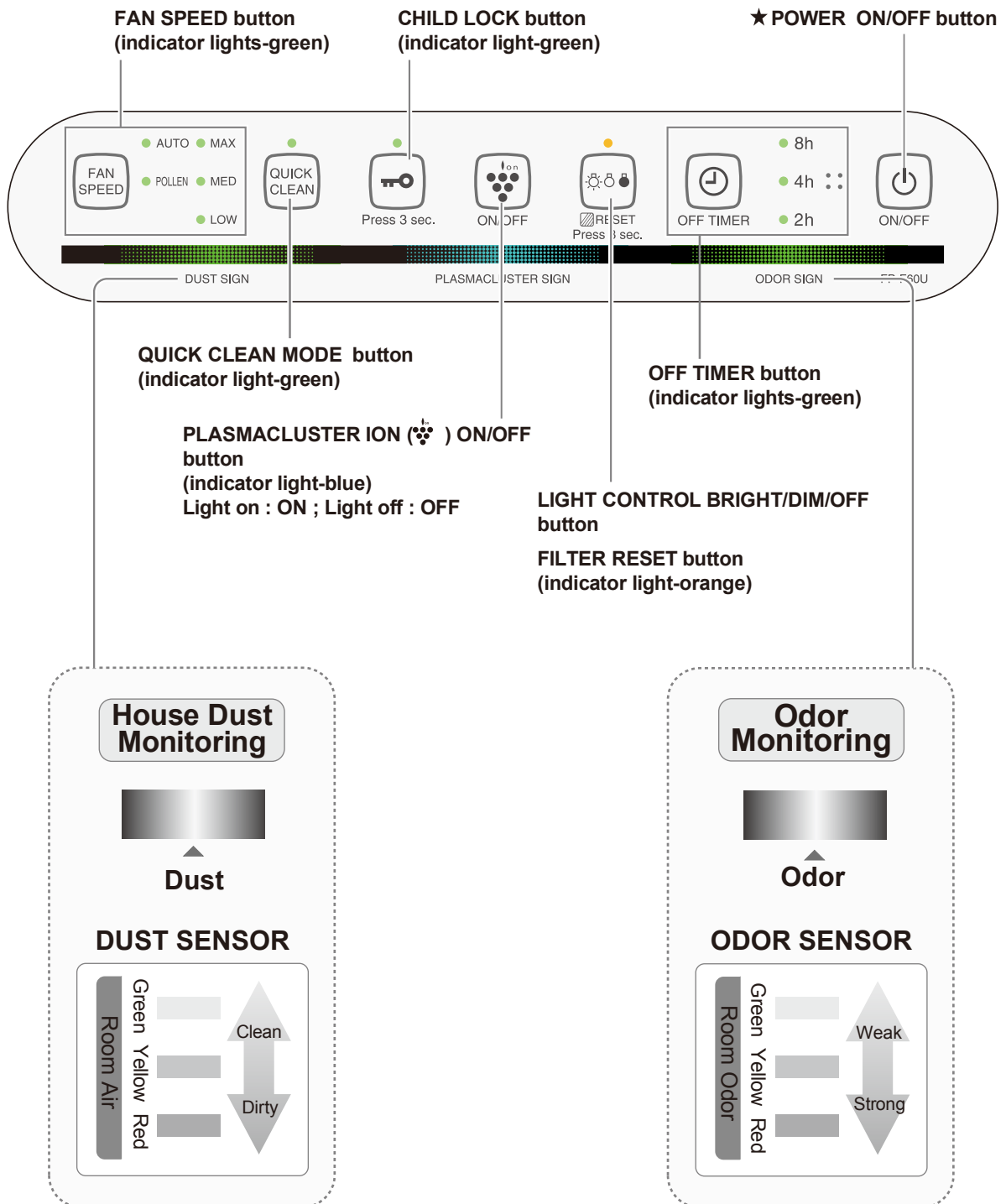

PREPARATION FOR USE Unplug the unit before installing or adjusting the filters.

FILTER INSTALLATION

1 Remove the back panel (pre-filter).

There are two filters in the main unit.

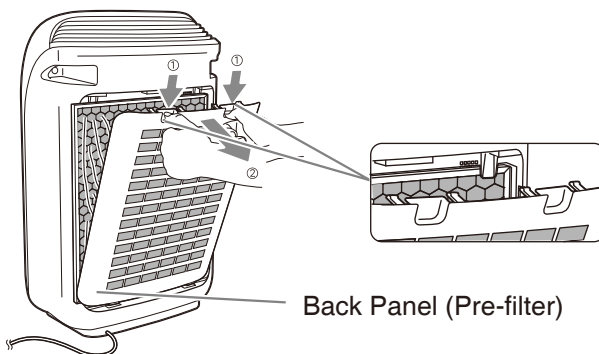

2 Take out the two filters from the plastic bags.

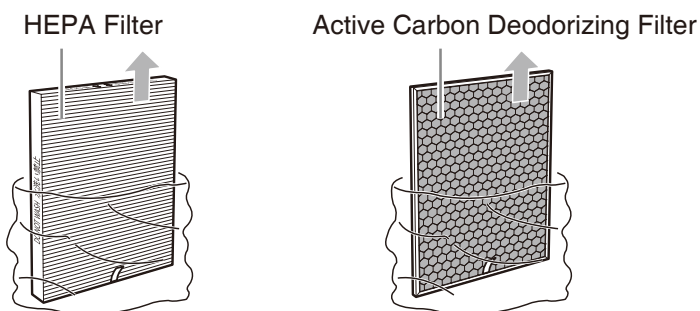

3 The side marked with FRONT shall face outward.

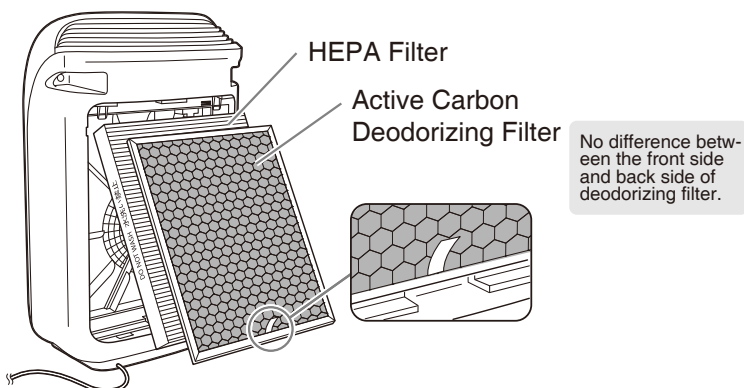

The figure on the upper shows the installation order of the HEPA filter and the Active Carbon Deodorizing Filter.

4 Install the back panel (pre-filter).

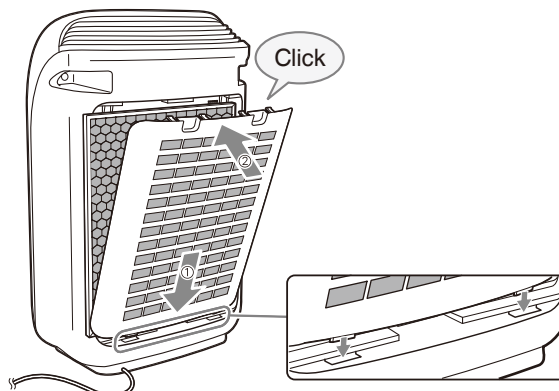

OPERATION

CONTROL PANEL

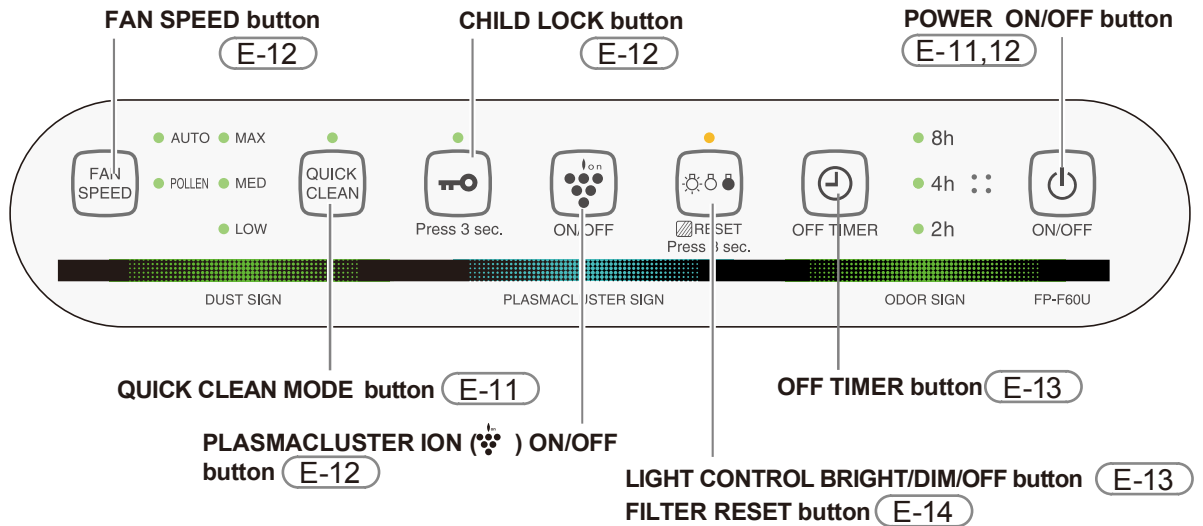

CLEAN AIR MODE(NORMAL OPERATION)

- 1 Press the **POWER ON/OFF** button on the display.
 - If the power cord was not unplugged between uses, the unit will automatically re-start at the previously selected settings.



- 2 Press the **FAN SPEED** BUTTON to select the desired fan speed. (See E-12)



QUICK CLEAN MODE

QUICK CLEAN Mode releases high-density Plasmacluster ions. By continuously discharging strong airflow cycles, the unit effectively removes airborne dust, pollen, mold and allergens from the air as they are drawn through the filter system.

- 1 Press the **QUICK CLEAN MODE** Button on the display to select this mode.

When the operation finishes, the unit will return to the prior operation.



OPERATION

FAN SPEED Button

Press the FAN SPEED Button to select the preferred fan settings. Indicator lights will show the speed currently selected. Please note the fan speed cannot be adjusted during the QUICK CLEAN Mode.

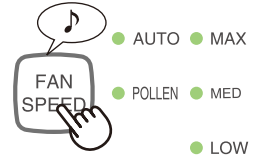

AUTO operation AUTO

The fan speed is automatically controlled depending on the amount of impurities in the air. The sensors detect the impurities for efficient air purification.

POLLEN mode operation POLLEN

The unit will operate at High level for 10 minutes, then will alternated between MED and HIGH every 20 minutes.

MAX operation MAX

The unit will operate at maximum fan speed .

MEDIUM operation MED

The unit will operate at medium fan speed .

LOW operation LOW

The unit will operate quietly using minimal air intake.

Plasmacluster ON/OFF Button

Press the Plasmacluster ON/OFF Button to turn Plasmacluster Ion Mode ON and OFF. When Plasmacluster is ON, both the Indicator Light and Plasmacluster Indicator Light on the front display turn on.



CHILD LOCK Button

When you want to prevent children or pets from changing operation.

To enable



To disable



Press and hold 3 seconds or longer

NOTE

While CHILD LOCK is enabled, all functions of the control are locked.

POWER ON/OFF Button

Press the Power ON/OFF Button to turn the unit off or on.



LIGHT CONTROL BRIGHT/DIM/OFF button

Use when the light on the control panel is too bright.

Refer to the diagram to select the desired brightness on the front panel.

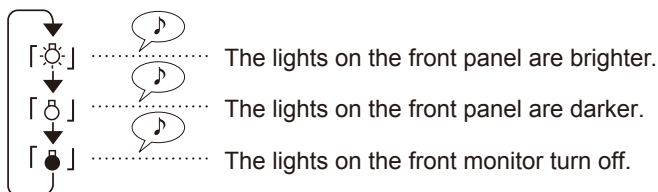

NOTE:

The lights on the control panel are always brighter when first operating.

OFF TIMER button

When you want to set the auto shutdown time.

ENABLE

(Running)

Beep



● Each press will change the setting in the following sequence.

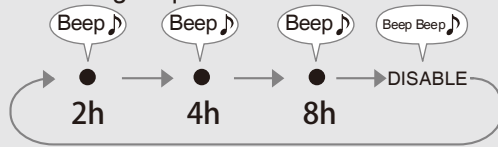

DISABLE

Beep Beep



ADJUSTMENT OF SENSOR DETECTION SENSITIVITY

Set to 'low' if the DUST MONITOR is constantly red to reduce sensitivity, and set to 'high' if the DUST MONITOR is constantly green to increase sensitivity.

1 With the unit OFF, press the Fan Speed Button for 3 seconds.

The Fan Speed Indicator Lights will display the currently set sensor sensitivity level. The factory setting is Standard, indicated by the MED light.

2 Press the Fan Speed Button to set the desired sensor sensitivity.

Refer to the diagram on the right to select the desired sensor sensitivity level.

Fan Speed Indicator Light

Sensor Detection sensitivity

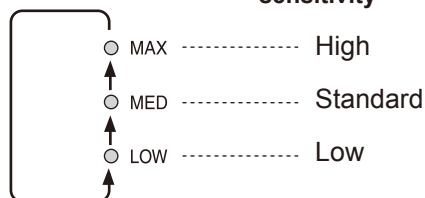

3 Press the Power OFF Button.

Note that if the Power OFF Button is not pushed within 8 seconds of adjusting sensor sensitivity, the setting will be saved automatically. The sensor sensitivity setting will be saved even if the unit is subsequently unplugged.

CARE AND MAINTENANCE



Before maintenance, be sure to shut down the unit and remove its power plug. [Otherwise, electric shock or injury may be caused.]

BACK PANEL (PRE-FILTER) Once a month

The indicator light is lit when it is time to maintain the back panel (pre-filter).

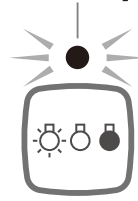

RESET
Press 3 sec

- The indicator light will be lit in one month if the unit works 24 hours a day.

1 Service the back panel (pre-filter).

ROUTINE MAINTENANCE

Use a vacuum cleaner to remove the dust.

NOTE

Be careful not to apply too much force to the filter.

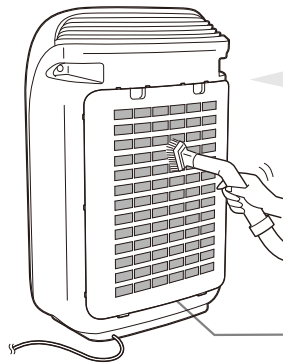

- Service the filter while it is mounted.

Back Panel (Pre-Filter)

As-Needed MAINTENANCE

Back Panel (Pre-Filter)

- Soak the back panel in water with a small amount of dish soap.
- Rinse the back panel repeatedly with clean water to remove the solution residue.
- Drip Dry the panel to remove excess water.

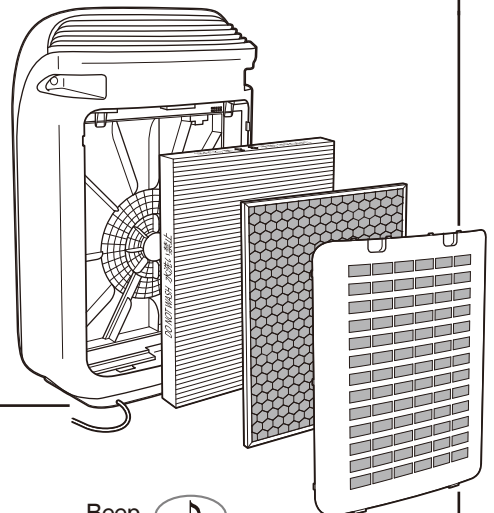
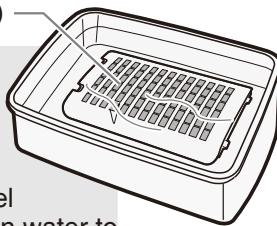

2 After maintenance, insert the power plug. When the unit starts to run, press and hold the FILTER RESET button for 3 seconds or longer until the indicator light is off.

After maintenance, press and hold the FILTER RESET button for 3 seconds or longer to reset the operation time even if the indicator light is not lit.

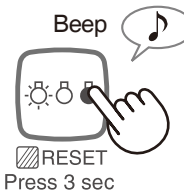

RESET
Press 3 sec

To keep the unit clean and maintain its long life, we recommend regular care and maintenance.

MAIN UNIT Surface cleaning

Remove the power plug, and then **wipe** the main unit with a soft cloth.



Never wash the main unit with water.

Do not use the following articles:
(Otherwise, surface scratch and internal liquid leakage may cause malfunction.)



Do not use volatile fluids or detergents.

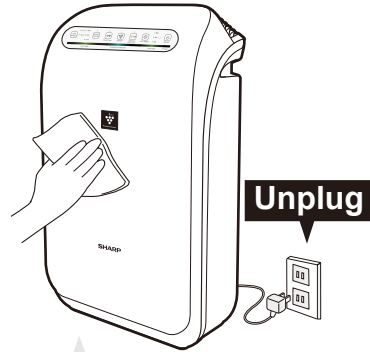

If there are stubborn stains, wipe them off with a cloth moistened with water or warm water (below 100°F).

HEPA FILTER, ACTIVE CARBON DEODORIZING FILTER

When odor comes out from the air outlet or it is difficult to remove odor.

Clean both the HEPA filter and the Active Carbon Deodorizing Fi

HEPA Filter

Gently vacuum the dust.



Never wash the filter with water. (Otherwise, the performance of the filter may be degraded.)

Clean carefully

Put a piece of paper under the filter to keep dirt off the surrounding area.

- Only clean the side marked with **FRONT** on the frame. Do not clean the side marked with **BACK** on the frame of the filter.

(Otherwise, the performance of the filter may be degraded.)

- Remove the dust from the filter. Do not apply too much force because the filter may be damaged easily.

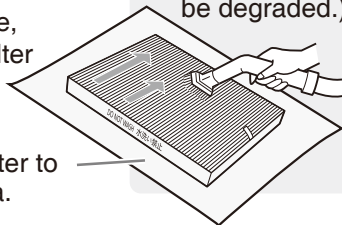

Active Carbon Deodorizing Filter



Never wash the filter with water. (Otherwise, the performance of the filter may be degraded.)

Absorb the dust gently

Put a piece of paper under the filter to keep dirt off the surrounding area.

- Clean both sides of the filter.

Please note that too much force may damage the filter.

- Remove the dust on the filter.

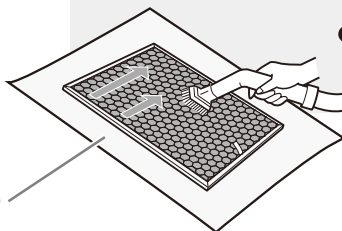

NOTE

Never expose the filter to direct sunlight. (Otherwise, the filter may lose effectiveness.)

CARE AND MAINTENANCE

FILTER REPLACEMENT GUIDELINES



Before maintenance, be sure to shut down the unit and remove its power plug.
[Otherwise, electric shock or injury may occur.]

HEPA FILTER, ACTIVE CARBON DEODORIZING FILTER

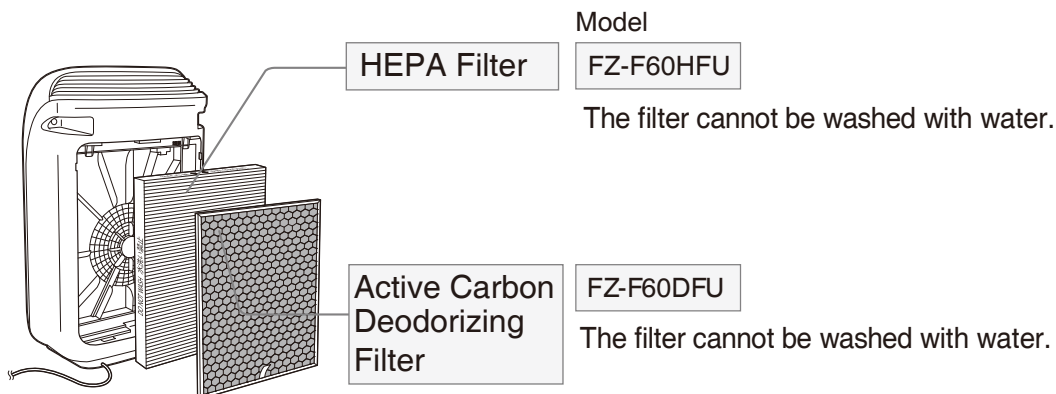

NOTE

- Put a piece of paper under the filter during replacement to avoid getting the surrounding area dirty.
- In harsh environments filter replacement should be more frequent.

Replacing the Filters

1. Replace filters according to the instructions provided with the replacement filters.
2. Use the date labels as a reminder for when the filters should be replaced.

Replacement and Maintenance Cycle

Filter Name	Maintenance Cycle	Max Service Life	Replacement Filter Model
HEPA Filter	When odor emanates from the air outlet	5 years	FZ-F60HFU
Active Carbon Deodorizing Filter※			FZ-F60DFU

※ According to Japan Electric Manufacture's Association JEM 1467, the Max service life is based on the equivalent condition of the smoke from 5 cigarettes per day whereby the dust collection/deodorization power is reduced by half compared with that of new filter. It is recommended to replace the filter more frequently under more severe conditions.

Disposal of Filters

Please dispose of used filters according to any local laws and regulations.

HEPA filter materials:

- Filter: Polypropylene · Frame: Polyester

Active Carbon Deodorizing Filter Materials:

- Polyester, Rayon, Activated charcoal

TROUBLESHOOTING

Before calling for service, please review the Troubleshooting chart below, since the problem may not be a unit malfunction.

	Problem	Solution	Reference Page												
ODOR	The odor or smoke in room is not being reduced.	<ul style="list-style-type: none"> ● Is the filter still wrapped in the plastic bag? ⇒ Take out the filter from the plastic bag. ● Is the air flow diminished? ⇒ Clean the areas with ★ in the following table: <table border="1"> <thead> <tr> <th colspan="4">Cleaning Areas</th> </tr> <tr> <th>Main Unit</th> <th>Back Panel</th> <th>Active Carbon Deodorizing Filter</th> <th>HEPA Filter</th> </tr> </thead> <tbody> <tr> <td></td> <td>★</td> <td>★</td> <td>★</td> </tr> </tbody> </table>	Cleaning Areas				Main Unit	Back Panel	Active Carbon Deodorizing Filter	HEPA Filter		★	★	★	E - 10 E - 14~15
	Cleaning Areas														
Main Unit	Back Panel	Active Carbon Deodorizing Filter	HEPA Filter												
	★	★	★												
	Odor emanates from the air outlet.	<ul style="list-style-type: none"> ● Is the unit used in a room with strong smells? If the unit is used in the presence of strong smells such as cigarette smoke, the filters may smell . ⇒ It is recommended to frequently ventilate the room where the air purifier is used. ● Clean the areas with ★ in the following table, if odor persists, replace the filters. <table border="1"> <thead> <tr> <th colspan="4">Cleaning Areas</th> </tr> <tr> <th>Main Unit</th> <th>Back Panel</th> <th>Active Carbon Deodorizing Filter</th> <th>HEPA Filter</th> </tr> </thead> <tbody> <tr> <td></td> <td></td> <td>★</td> <td>★</td> </tr> </tbody> </table>	Cleaning Areas				Main Unit	Back Panel	Active Carbon Deodorizing Filter	HEPA Filter			★	★	— E - 14~15
Cleaning Areas															
Main Unit	Back Panel	Active Carbon Deodorizing Filter	HEPA Filter												
		★	★												
INDICATOR LIGHT	The FILTER RESET indicator light is lit.	<ul style="list-style-type: none"> ● Clean the areas with ★ in the following table: <table border="1"> <thead> <tr> <th colspan="4">Cleaning Areas</th> </tr> <tr> <th>Main Unit</th> <th>Back Panel</th> <th>Active Carbon Deodorizing Filter</th> <th>HEPA Filter</th> </tr> </thead> <tbody> <tr> <td></td> <td>★</td> <td></td> <td></td> </tr> </tbody> </table>	Cleaning Areas				Main Unit	Back Panel	Active Carbon Deodorizing Filter	HEPA Filter		★			E - 14
	Cleaning Areas														
Main Unit	Back Panel	Active Carbon Deodorizing Filter	HEPA Filter												
	★														
	The FILTER RESET indicator light does not turn off.	<ul style="list-style-type: none"> ● After maintenance, press and hold the FILTER RESET (BRIGHT/DIM/OFF) button for 3 seconds or longer. 	E - 14												
SOUND	Clicking or ticking sounds are heard.	<ul style="list-style-type: none"> ● Clicking or ticking sounds may be audible when the unit is generating ions. 	—												

TROUBLESHOOTING

Doublecheck before you call for service.

Problem	Solution	Reference Page
<p>The Indicator Light does not change.</p>	<ul style="list-style-type: none"> ● When starting operation, the sensor may not react instantly to dust and odors. <ul style="list-style-type: none"> ⇒ After the unit has been running for several minutes, the sensor sensitivity will become stable. ● To test the sensors, shake a dusty cloth near the sensor opening to see if the light changes color. ● If you switch the unit on when the room has a strong smell, the sensitivity of the odor sensor may be temporarily deteriorated. <ul style="list-style-type: none"> ⇒ Set Fan Speed to MED and run the unit for several hours. 	<p>E - 13</p> <p>—</p> <p>—</p>
<p>The Indicator Light never turns green.</p>	<ul style="list-style-type: none"> ● The doors or windows may be open. A sealed environment is needed to maximize air cleaning performance. 	<p>—</p>
<p>The Indicator Light switches its state frequently.</p>	<ul style="list-style-type: none"> ● Frequent door opening and closing or airflow and temperature changes may cause reactions. 	<p>—</p>
<p>The Indicator Light is too bright.</p>	<ul style="list-style-type: none"> ● Adjust the brightness of indicator lights. Press the Light Control (BRIGHT/DIM/OFF) button. 	<p>E - 13</p>

DUST/ODOR SENSOR

ENGLISH

SPECIFICATIONS

Model		FP-F60U-W		
Power supply		120 V 60 Hz		
Fan Speed Adjustment		MAX	MED	LOW
CLEAN AIR	Fan Speed (CFM)	202	111	44
	Rated Power (W)	55	12	4
	Noise Level (dBA)	52.8	39.4	26.3
Recommended Room Size*		280 sq.ft(26m ²)		
CADR (Dust/Smoke/Pollen)		194/181/202		
Sensors		Dust/odor		
Filter type	Dust collection	True HEPA with Microbial control		
	Deodorization	Active Carbon Deodorizing		
Cord Length		5.9 ft (1.8m)		
Dimensions		357mm (W) × 201mm (D) × 576mm (H) 14 in (W) × 7 ⁹ / ₁₀ in (D) × 22 ² / ₃ in (H)		
Weight		12.1 lbs (5.5 kg)		

* The recommended room size is appropriate for operating the unit at maximum fan speed

Standby Power

In order to operate the electrical circuits while the power plug is inserted in the wall outlet, this product consumes about 0.5 W of standby power.
For energy conservation, unplug the power cord when the unit is not in use.

