

**1215RSOD • 15" Outdoor Refrigerator • Outdoor Series**

**FEATURES & BENEFITS**



STAINLESS SOLID



STAINLESS SOLID (LOCK)

<b>PERFORMANCE</b>	<ul style="list-style-type: none"> <li>• Overall volume of 2.9 cu ft holds up to 57 bottles (12 oz) or 92 cans (12 oz)</li> <li>• Digital Touch Pad Control is conveniently located on upper face of unit</li> <li>• Temperature range: 34°F - 45°F</li> <li>• Passive cooling system</li> </ul>
<b>INTERIOR/EXTERIOR</b>	<ul style="list-style-type: none"> <li>• White interior is illuminated with LED lighting</li> <li>• Three removable tempered glass shelves</li> <li>• Stainless steel handle</li> <li>• Full stainless steel cabinet and door are deemed suitable for outdoor use by UL</li> <li>• Door swing is field reversible, and is shipped right-hand hinged</li> <li>• Door lock model available</li> </ul>
<b>INTEGRATION</b>	<ul style="list-style-type: none"> <li>• Unit is designed to be built-in or can be freestanding</li> <li>• Four independently adjustable leveling legs provide a precise undercounter fit</li> </ul>

**MODEL DETAILS**

Model	Voltage/Hz	Door Swing	Finish	Shipping Weight
U-1215RSOD-00B	115 / 60	Field Reversible	Stainless Solid	83 lb
U-1215RSOD-13A	115 / 60	Field Reversible	Stainless Solid (Lock)	83 lb

Outdoor Series • 15" Outdoor Refrigerator • **1215RSOD**

**DIMENSIONS**

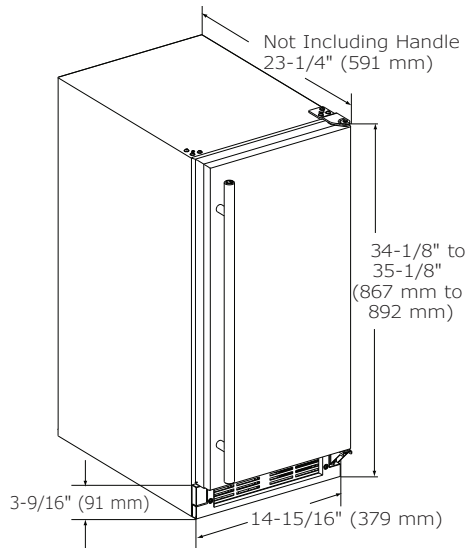

**SPECIFICATIONS**

Model	1215RSOD
Amps: Running	1.2
Capacity: Bottle (12 oz)	57
Capacity: Can (12 oz)	92
Capacity: Volume (cu ft)	2.9
Capacity: Wine Bottle (750 ml)	N/A
Control Type	Digital Touch Pad
Dimensions: Depth	23 1/4" / 591 mm
Dimensions: Height	34 1/8" / 867 mm
Dimensions: Width	14 15/16" / 379 mm
Energy Consumption: Avg. Per Year	225 kWh
ENERGY STAR	ENERGY STAR / Tier 3
Product Weight: Max	76 lb
Refrigerant Type	R600a
Sabbath (Star K Certified)	Yes
Temperature Range	34°F - 45°F

**CABINET CUT-OUT**

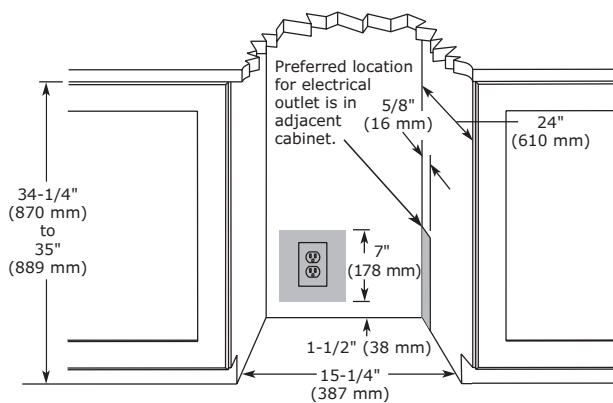

**INSTALLATION NOTES**

When installing adjacent to wall, ensure 2-1/2" clearance on hinged side for 90° door opening, allowing ample room for door handle.

Cutout includes the additional 1/4" width overall to ensure proper installation.

No additional clearance around sides, top or rear of unit is needed for ventilation.

Do not obstruct front grille air flow.

**COOLING SYSTEM**



**ELECTRICAL REQUIREMENTS**

This unit requires a grounded, polarized 115 VAC, 60 Hz, 15 A power supply (normal household current).



Warranty

Please visit [u-line.com](http://u-line.com) to view this model's User Guide & Service Manual. All Specifications are subject to change without notice.

Deemed suitable for outdoor use by UL.