

REFRIGERATOR FEATURES AND SPECIFICATIONS

ORIGINAL SIZE– 20.6 cu.ft.

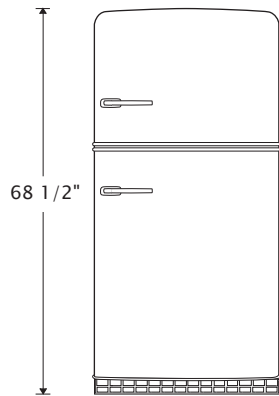

RETROPOLITAN– 18.5 cu.ft.

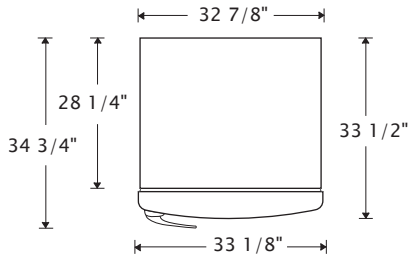
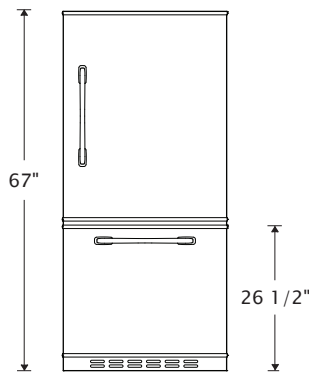
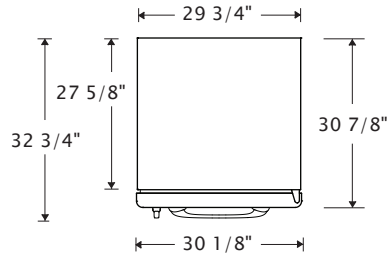

STUDIO SERIES– 14.4 cu.ft.

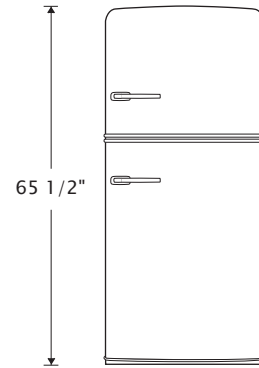
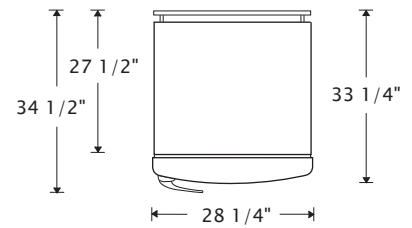

Total Capacity	20.6 cu. ft.	Total Capacity	18.5 cu. ft.	Total Capacity	14.4 cu. ft.
Refrigerator Capacity	14.4 cu. ft.	Refrigerator Capacity	12.9 cu. ft.	Refrigerator Capacity	10.6 cu. ft.
Freezer Capacity	6.2 cu. ft.	Freezer Capacity	5.6 cu. ft.	Freezer Capacity	3.8 cu. ft.
Clearance: Back	1/2"	Clearance: Back	1/2"	Clearance: Back	1/2"
Clearance: Side	1/4"	Clearance: Side	1/4"	Clearance: Side	1/4"
Side Clearance for door to open 90°	4 1/2"	Side Clearance for door to open 90°	3 1/2"	Side Clearance for door to open 90°	4 1/2"
Adjustable Rollers	Standard	Adjustable Rollers	Standard	Adjustable Rollers	Standard
Energy Guide (kWh/year)	416 (E Star)	Energy Guide (kWh/year)	448 (E Star)	Energy Guide (kWh/year)	438
Electrical	115V, 60Hz, AC only, 15 or 20 amp fused	Electrical	115V, 60Hz, AC only, 15 or 20 amp fused	Electrical	115V, 60Hz, AC only, 15 or 20 amp fused

FEATURES:

Stamped Metal Body, Chrome Trim, 2 Half-Width Clear Crisper Drawers, Gallon Door Storage, Temperature Management System, 1 Fixed Full-Width Freezer Shelf, 3 Easy-Clean Spill-Proof Glass Shelves, Energy Star Rated, Optional Ice Maker, Available Left Hand Hinge, 1 Year Parts and Labor Warranty

FEATURES:

Stamped Metal Body, Chrome Trim, Energy Star Rated, Gallon Door Storage, 2 Half-Width Clear Crisper Drawers, Four Half-Width Adjustable Glass Shelves, Temperature Management System, Slide-Out Upper Freezer Basket, Glide-Out Freezer Basket with Organizer, Optional Ice Maker, Available Left Hand Hinge, 1 Year Parts and Labor Warranty

FEATURES:

Stamped Metal Body, Chrome Trim, 2 Half-Width Crisper Drawers, Adjustable Shelving, Available Left, Hand Hinge, Temperature Management System, Optional Ice Maker, 1 Year Parts and Labor Warranty



TEL: 1-877-842-3269

EMAIL: info@bigchill.com

WEB: www.bigchill.com

RANGE FEATURES AND SPECIFICATIONS

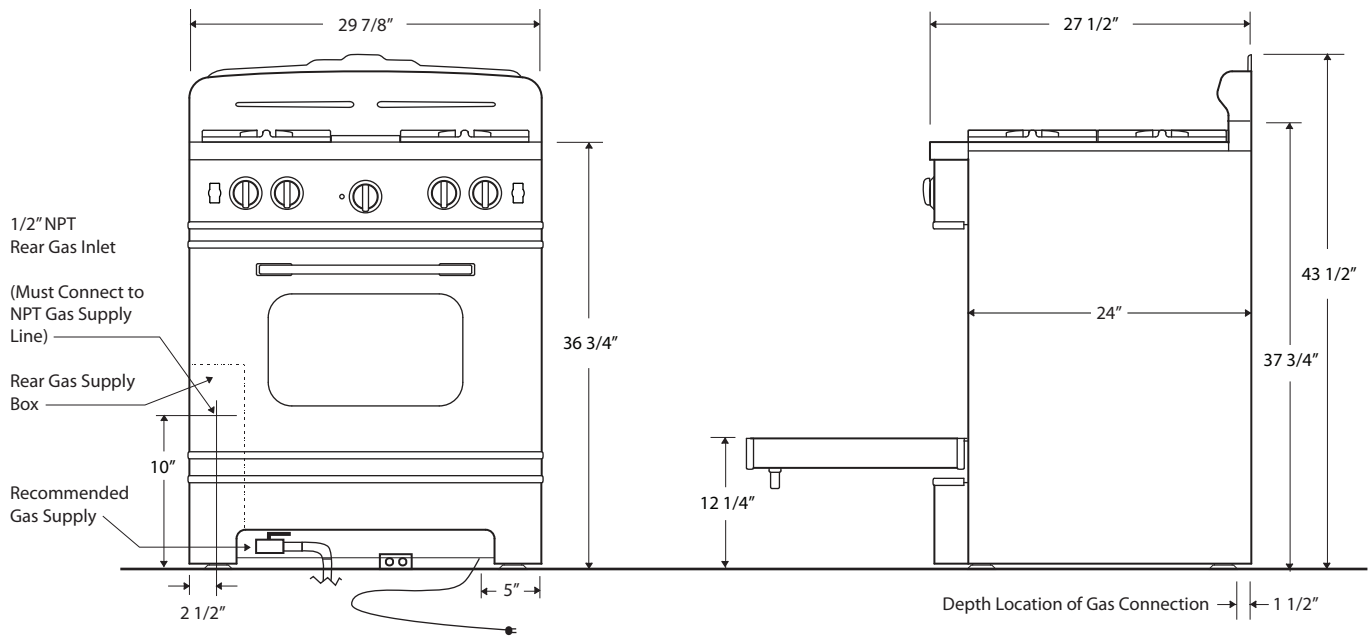

Front Burners	15,000 BTU	*Easy to clean Sealed Burner Top
Back Left Burner (Simmer)	6,000 BTU	*Automatic electronic ignition and re-ignition system
Back Right Burner	10,000 BTU	*24" depth for compatibility with standard kitchen cabinetry
Infrared Broiler Rating	15,000 BTU	*Convection fan
Oven Burner Rating	30,000 BTU	*Full Extension oven rack
Electrical Requirements	120 VAC, 15 Amps,	*Heavy-duty, commercial stainless steel construction
*(Unit must be on a non-GFI, dedicated outlet)	Single Phase	*1 year parts and labor warranty
Operating Gas Pressure	NAT: 5.0" WC LP: 10.0" WC	OVEN CAPACITY:
Install Clearance:	0" Side Cabinet 0" Back Wall 3" Top Cabinet Per Side	The cavity design of the oven provides the most precise temperature control, which delivers even heat distribution resulting in versatile performance. It has the largest oven capacity available on a 30" range and will accommodate a full-size commercial 18" x 26" baking sheet.

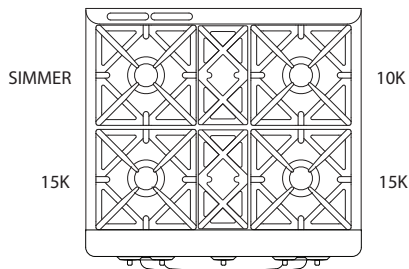

INFRARED BROILER:

Because of its popularity in the commercial market, the direct-fired ceramic infrared broiler is standard on all residential ranges. The large burner produces 1850 F of intense, searing heat close to the burner, while effecting a gentler broiling for foods placed farther away. The broiler is fully recessed into the oven's top to create maximum cooking space.

FULL MOTION GRATES:

Bring sauce to a boil while stirring on a front burner, then slide it to the rear to simmer while you saute up front! Our full motion grates allow you to easily reposition pots and pans from front to rear burners without lifting. The grates are also oversized to accommodate the largest stock pots and saute pans.



36" RANGE FEATURES AND SPECIFICATIONS

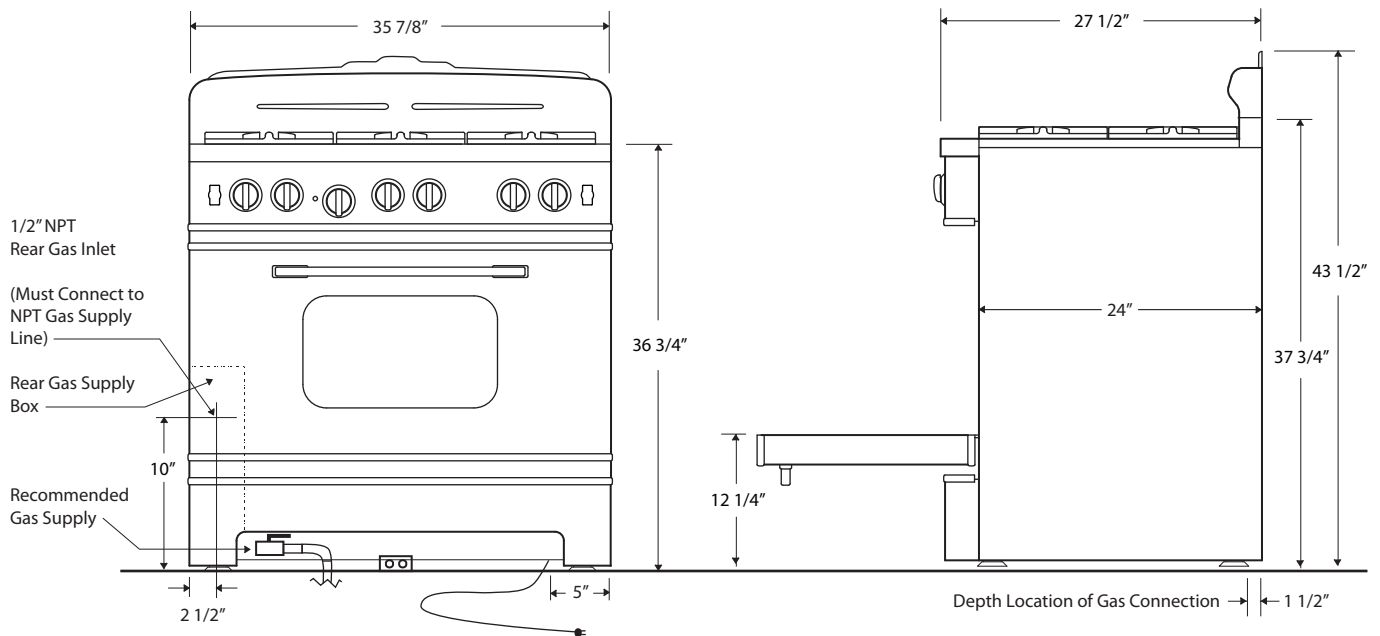

Front Burners	15,000 BTU	*Easy to clean Sealed Burner Top
Back Left Burner (Simmer)	6,000 BTU	*Automatic electronic ignition and re-ignition system
Back Right Burners	10,000 BTU	*24" depth for compatibility with standard kitchen cabinetry
Infrared Broiler Rating	15,000 BTU	*Convection fan
Oven Burner Rating	30,000 BTU	*Full Extension oven rack
Electrical Requirements	120 VAC, 15 Amps,	*Heavy-duty, commercial stainless steel construction
*(Unit must be on a non-GFI, dedicated outlet)	Single Phase	*1 year parts and labor warranty
Operating Gas Pressure	NAT: 5.0" WC LP: 10.0" WC	OVEN CAPACITY:
Install Clearance:	0" Side Cabinet 0" Back Wall 3" Top Cabinet Per Side	The cavity design of the oven provides the most precise temperature control, which delivers even heat distribution resulting in versatile performance. It has the largest oven capacity available on a 36" range and will accommodate a full-size commercial 18" x 26" baking sheet.

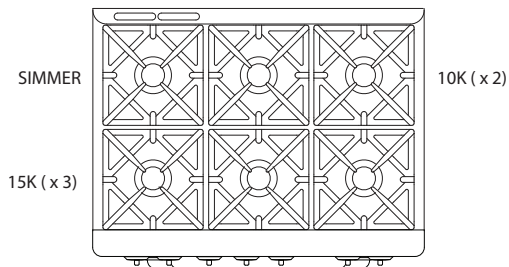

INFRARED BROILER:

Because of its popularity in the commercial market, the direct-fired ceramic infrared broiler is standard on all residential ranges. The large burner produces 1850 F of intense, searing heat close to the burner, while effecting a gentler broiling for foods placed farther away. The broiler is fully recessed into the oven's top to create maximum cooking space.

FULL MOTION GRATES:

Bring sauce to a boil while stirring on a front burner, then slide it to the rear to simmer while you saute up front! Our full motion grates allow you to easily reposition pots and pans from front to rear burners without lifting. The grates are also oversized to accommodate the largest stock pots and saute pans.

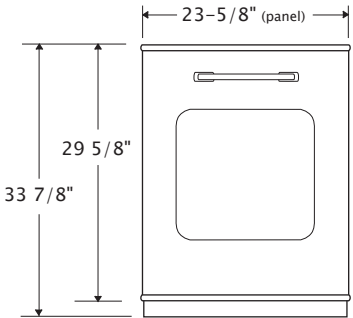
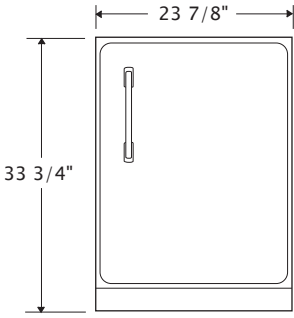
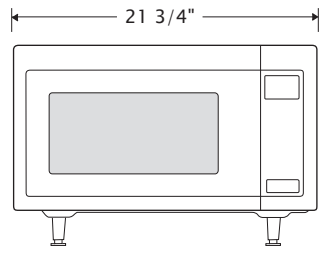
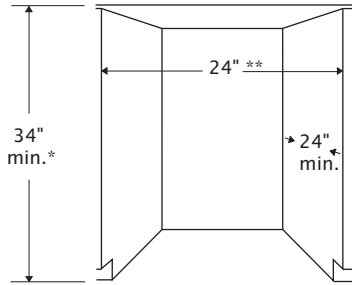
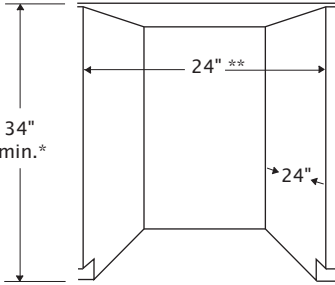
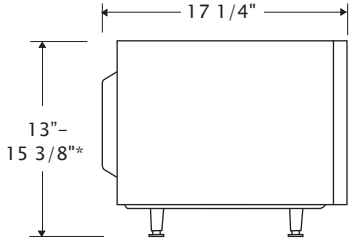

FEATURES AND SPECIFICATIONS

DISHWASHER	UNDER COUNTER REFRIGERATOR	COURTERTOP MICROWAVE			
					
					
Capacity	14 Place Settings	Capacity	6.1 cubic feet	Capacity	1.6 cubic feet
Cycles	4	Height	33-3/4"	Output Power	1200 Watts
Cycles	Heavy Duty, Normal, Light/ China, Rinse Only	Width	23-7/8"	Cooking Uniformity	13 1/2" Diameter Turntable
Cycle Options	6	Depth	25" (26-1/2" inc. handle)	Warranty	One Year Parts and Labor
Energy Guide	334 (kWh/year) (Energy Star Qualified)	Weight	120 lbs	Weight	38 lbs
Warranty	One Year Parts and Labor	Energy guide	301 (kWh/year) (Energy Star Qualified)	Electrical	15 Amp, 120 V, 60 Hz, AC only.
Electrical	15 or 20 Amp, 120 V, 60 Hz, AC only.	Warranty	One Year Parts and Labor, 5 Years on Compressor	FEATURES: With up to 1,200 watts of cooking power, you'll have the power you need to prepare all types of food. Sensor cooking tracks the progress of your food and automatically adjusts cooking time as needed to deliver optimal results. A recessed glass turntable also makes cooking with larger items, like cooking bowls, easy so you can prepare caramel corn, party mix and soups in the microwave.	
FEATURES: Stamped Metal Body, Authentic chrome trim, Whisper Quiet® Plus (52 dBA) Sound Reduction, Stainless Steel Interior, Energy Star		FEATURES: Stamped Metal Door, Temperature Management System, Energy Star, Optional Interior Freezer (Refrigerator 5.3 cu. ft., freezer 0.73 cu. ft.), Available Left Hand Hinge, Interior Shelving in both the door and cabinet, Includes door ajar alarm, Amber LED temperature display			
* Measured from the lowest point on the underside of countertop. ** Minimum, measured from narrowest point of opening.		* Measured from the lowest point on the underside of countertop. ** Minimum, measured from narrowest point of opening.		*Microwave can be ordered with or without legs. Height will vary between 13"-15 3/8" depending on selection.	



TOLL FREE: 1-877-842-3269

EMAIL: info@bigchill.com

WEB: www.bigchill.com

WALL OVEN FEATURES AND SPECIFICATIONS

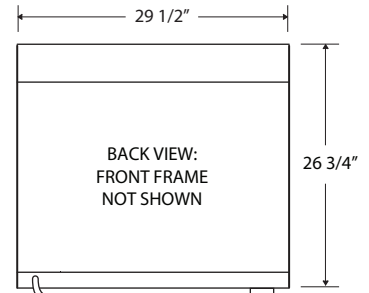
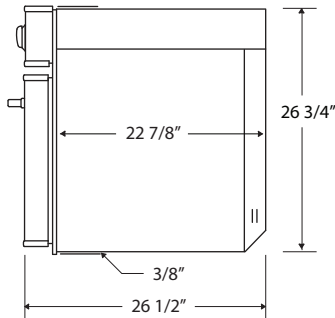
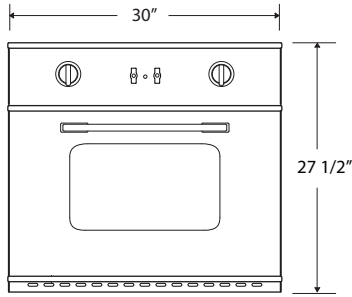

LOCATION OF ELECTRICAL CONNECTION. ATTACHED TO 20" FLEXIBLE CONDUIT.

FEATURES

- *4 cu.ft. Large Oven Capacity
- *2500 watt bake element
- *5000 watt broil element
- *Selectable convection mode
- *Coved corner interior with removable bottom for easy cleaning
- *Heavy duty, full extension oven racks
- *1 year parts and labor warranty
- *Traditional black/white stippled interior
- *Heavy-duty, stainless steel construction
- *Can be installed in wall or island
- *800 watt rear element
- *Simple controls
- *Can be stacked to double capacity

Oven Capacity

The cavity design of the oven provides the most precise temperature control, which delivers even heat distribution resulting in versatile performance. It has the largest oven capacity available on a 30" range and will accommodate a full-size commercial 18" x 26" baking sheet.

Electrical Requirements

240 Volt, 60 Hertz, 35AMPS, Single Phase
 *(Unit must be on a non-GFI, dedicated outlet)



CABINET CLEARANCES

*RECOMMENDED CABINET WIDTH IS 33"

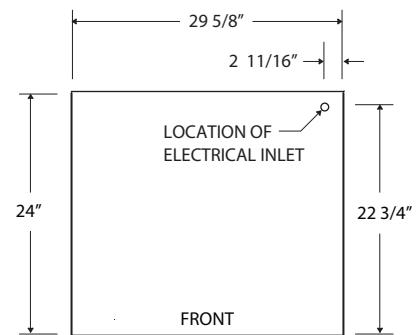
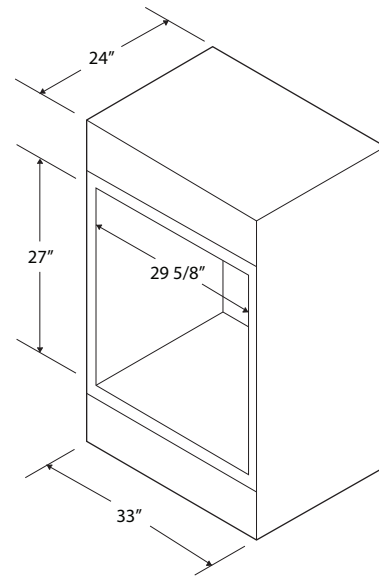

TOP VIEW CABINET



TOLL FREE: 1-877-842-3269

EMAIL: info@bigchill.com

WEB: www.bigchill.com

RANGE HOOD FEATURES AND SPECIFICATIONS

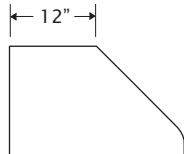
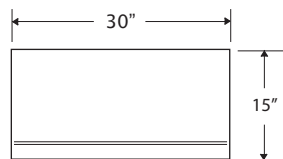
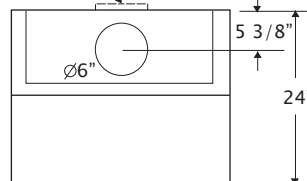
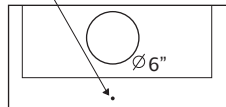
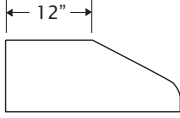
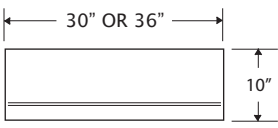
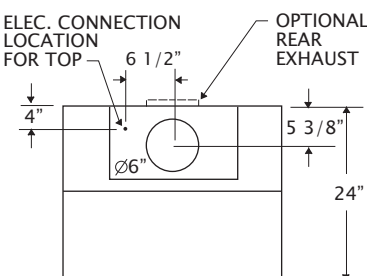
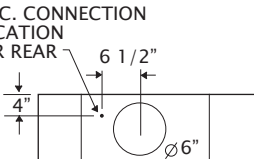
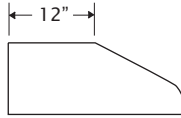
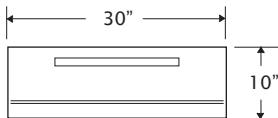
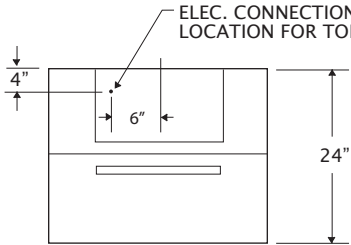
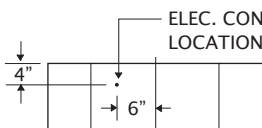
15" Hood	10" Hood	10" Hood—RECIRCULATING			
<p>MODELS: (BCH3015)</p>  <p>SIDE VIEW</p>  <p>FRONT VIEW</p> <p>OPTIONAL REAR EXHAUST</p>  <p>TOP VIEW</p> <p>ELEC. CONNECTION LOCATION</p>  <p>BACK VIEW</p>	<p>MODELS: (BCH3010) (BCH3610)</p>  <p>SIDE VIEW</p>  <p>FRONT VIEW</p> <p>ELEC. CONNECTION LOCATION FOR TOP</p>  <p>TOP VIEW</p> <p>ELEC. CONNECTION LOCATION FOR REAR</p>  <p>BACK VIEW</p>	<p>MODELS: (BCH3010R)</p>  <p>SIDE VIEW</p>  <p>FRONT VIEW</p> <p>ELEC. CONNECTION LOCATION FOR TOP</p>  <p>TOP VIEW</p> <p>ELEC. CONNECTION LOCATION FOR REAR</p>  <p>BACK VIEW</p>			
Dimensions	15"H x 30"W x 24"D	Dimensions	10"H x 30"W(OR 36") x 24"D	Dimensions	10"H x 30"W x 24"D
Vent	External, Reversible top or rear exhaust.	Vent	External, Reversible top or rear exhaust.	Vent	Recirculating
Blower	600 CFM	Blower	600 CFM	Blower	520 CFM
Electrical	120 VAC, 15 Amps	Electrical	120 VAC, 15 Amps	Electrical	120 V, 15 Amps

FEATURES:

Commercial grade 18 gauge 300 stainless steel construction, Welded seamless corners, Dishwasher safe stainless steel baffle filters, Variable blower control, Halogen lamps with dimmer control, Largest filtered capture in the industry

INSTALL NOTES:

Allow 30"-36" between stove top and bottom of range hood (or per your local city codes).

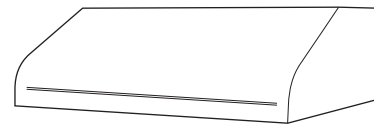

TOLL FREE: 1-877-842-3269

EMAIL: info@bigchill.com

WEB: www.bigchill.com

RANGE HOOD FEATURES AND SPECIFICATIONS

12" Tall Bungalow Hood

MODELS:
(BCH3012)
(BCH3612)

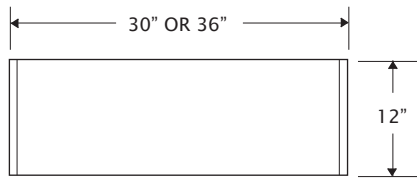

FRONT VIEW

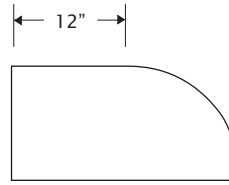

SIDE VIEW

OPTIONAL
REAR EXHAUST

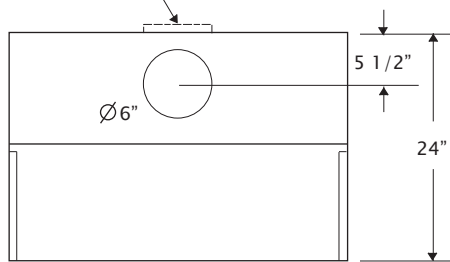

TOP VIEW

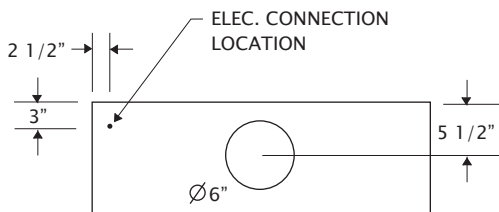

BACK VIEW

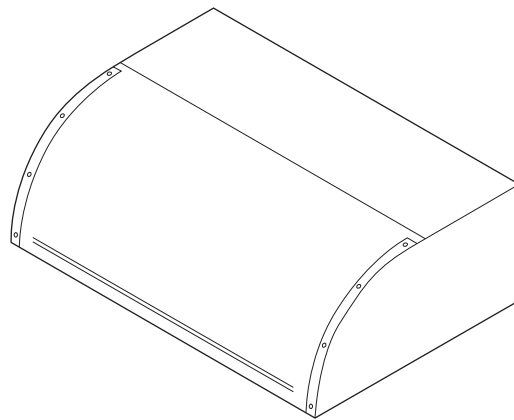

Dimensions	12"H x 30"W (OR 36") x 24"D
Vent	External, Reversible top or rear exhaust.
Blower	600 CFM
Electrical	120 VAC, 15 Amps

FEATURES:

Commercial grade 18 gauge 300 stainless steel construction, Welded seamless corners, Dishwasher safe stainless steel baffle filters, Variable blower control, Halogen lamps with dimmer control, Largest filtered capture in the industry

INSTALL NOTES:

Allow 30"-36" between stove top and bottom of range hood (or per your local city codes).



Big Chill

TOLL FREE: 1-877-842-3269

EMAIL: info@bigchill.com

WEB: www.bigchill.com