

## 5.83 Cubic Foot Built-In Beverage Center

BC100GS

Available Q3 2015



### Unit Specifications

|        |              |
|--------|--------------|
| Width  | 23 7/8"      |
| Depth  | 25 1/2"      |
| Height | 34 1/4"      |
| Weight | 121.5 lbs.   |
| UPC    | 688057381978 |

### More Easy-To-Use Features

- Stores up to 150 Cans
- 2 Glass Shelves
- Fold Away Shelf
- Temperature Range 34° – 50° Fahrenheit
- Sabbath Mode
- Door Ajar Alarm
- Storage Basket
- Zero Degree Door Clearance
- S/S Door w/ 3/4" Pro Style Handle
- Reversible Door
- Soft Lighting (Auto/Manual)
- Electronic Controls (Celsius/Fahrenheit)

### Signature Features

#### Electronic Control Display

Electronic temperature controls allow for precise temperature settings in one-degree

#### Adjustable Leveling Feet

Provides flexibility to account for varying surface levels

### Available Finishes



Stainless Steel

| Letter | Cutout Dimension      | in.     |
|--------|-----------------------|---------|
| A      | Height                | 35"     |
| B      | Depth                 | 24"     |
| C      | Width                 | 24"     |
| D      | Depth (door open 90°) | 46 3/8" |

| Power Requirements |            |
|--------------------|------------|
| Electrical Rating  | 115V, 60Hz |

| Overall Packaging Details |                  |
|---------------------------|------------------|
| Packaging                 | lb./in.          |
| Gross Weight              | 163.7 lbs.       |
| Dimensions                | <b>W</b> 26 1/4" |
|                           | <b>D</b> 28 1/4" |
|                           | <b>H</b> 37 1/4" |

### Product Technical Illustration

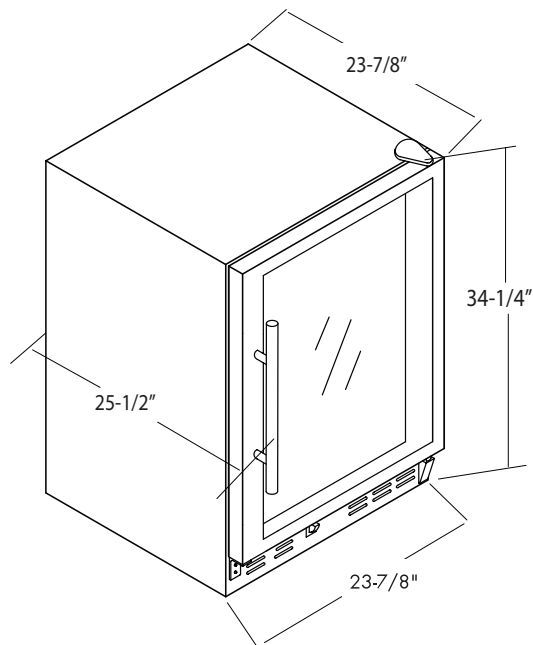

### General Appliance Information

Please read all installation details and instructions before use.

### Contact Us

For questions regarding this product please refer to our website at [haier.com](http://haier.com) or call our customer service center at 877-337-3639.

