

24" ENERGY STAR® Qualified Built-In Dishwasher

HDBL865ATS

Available Q3 2015

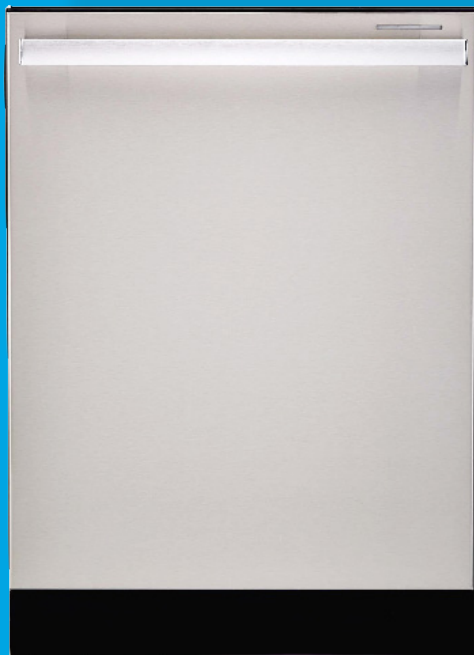

Signature Features

Fully Integrated Display

Top controls and display give the dishwasher a sharp, clean appearance

Exterior Status Indicator Bar

Indicator bar informs the user the status of the wash cycle

Third Rack

Provides extra space for silverware and utensils needs

45 dba Soundpack

Quiet dishwasher that has an exterior status bar to indicate its operating

Unit Specifications

Width	23 7/8"
Depth	25 1/4"
Height	33 7/8"
Weight	96.8 lbs.
UPC	688057350707

More Easy-To-Use Features

- Fully Integrated Display
- Exterior Status Indicator Bar
- ScrubZone Wash
- Fresh Vent Option
- SteamRite Technology
- 6 Wash Levels/ 3 Wash Arms
- DishGuard Nylon Rack with 16 Place Settings
- Third Rack
- Quiet Design II + Sound Pack (45dBA)
- 8 Multi-Positional Tines (6-LR, 2-UR)
- 6 Cycles, *NSF® Certified Sanitized Rinse
- 3-Piece Flexible Silverware Basket
- Countdown Timer
- Turbidity Sensor
- Bottle Holder
- One-Touch Upper Rack Adjustor
- 2 Cup-shelves with StemGuard
- Delay Start
- Stainless Steel, Dual Pump Triple Filtration
- Child Lock

Warranty

- 2 Year Warranty (Parts and Labor)

Available Finishes



Stainless Steel

haier.com

Letter	Cutout Dimension	in.
A	Height	34"
B	Depth	18"
C	Width	24"
D	Depth (door open 90°)	25 5/8"

Overall Packaging Details

Packaging	lb./in.
Gross Weight	116.6 lbs.
Dimensions	W 29"
	D 27 1/2"
	H 35"

Power Requirements

Electrical Rating	120V, 60Hz
Energy Use	265kWh

Product Technical Illustration

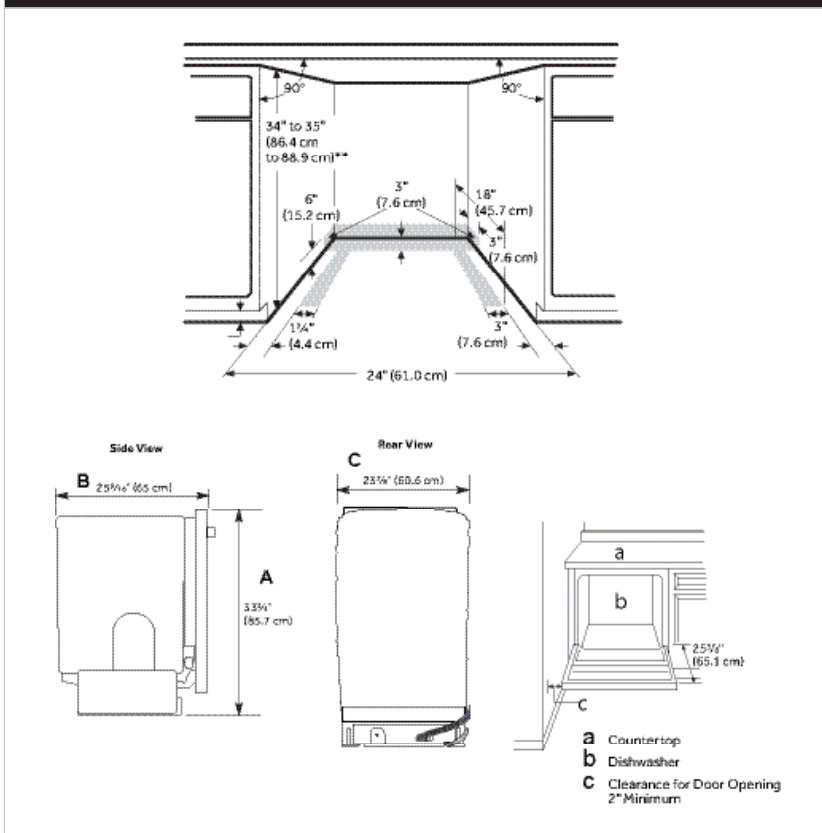

General Appliance Information

Please read all installation details and instructions before use.

Contact Us

For questions regarding this product please refer to our website at haier.com or call our customer service center at 877-337-3639.

