

4 DOOR French Door,
Anti-Fingerprint Stainless Steel,
92CM, A+ Energy Rating,
Ice & Water Dispenser
EAN13: 8017709193362

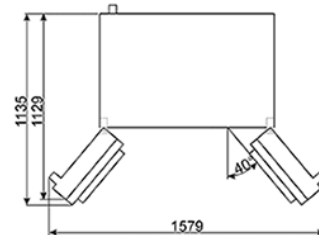
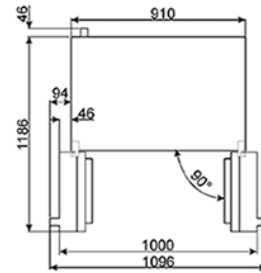
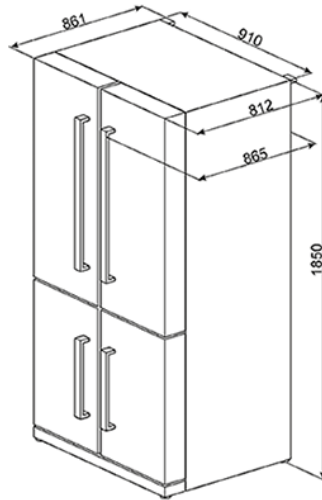

- **Aesthetics** • Material: Stainless steel • Stainless steel type: Finger proof • Door colour: Steel • Side material: Steel • Display: LCD • Dispenser: Ice & water • **Refrigerator compartment features** • Type of adjustable shelves: Glass • Crisper cover • Type of crisper cover: Glass • Refr internal lighting • Refr internal lighting type: Leds • Life Plus zone • **Refrigerator Inner Door** • Number of balconies with transparent cover: 1 • Number of adjustable balconies: 5 • Number of bottle balconies: 2 • **Other Refrigerator features** • Accessories: Eggs tray • Active fresh blue light • MultiFlow • Fan • **Freezer compartment features** • Number of drawers: 4 • Number of shelves: 2 • Shelves type: Glass • **Other Freezer features** • Fast freezing compartment • **Other technical features** • Fast freezing button • **Performance / Energy Label** • Energy efficiency class: A+ • Annual energy consumption: 531 kWh • Storage volume fresh food compartment: 435 litros • Storage frozen food compartment: 208 litros • Star rating frozen food compartment: 4 • No - Frost system: Total • Temperature rising time: 15 h • Freezing capacity: 13 kg/24h • Climatic class: SN, N, ST, T • Noise level: 46 dB re 1 pw • **Electrical Connection** • Voltage (V): 220-240 V • Frequency (Hz): 50 Hz • Plug type: Schuko