

Discovery[®] Built-In Refrigerator

*Models: DYF30BFBPL, DYF30BFBPR, DYF30BFBSL,
DYF30BFBSR, DYF30BFTSL, DYF30BFTSR,
DYF36BFBPL, DYF36BFBPR, DYF36BFBSL,
DYF36BFBSR, DYF36BFTSL, DYF36BFTSR*

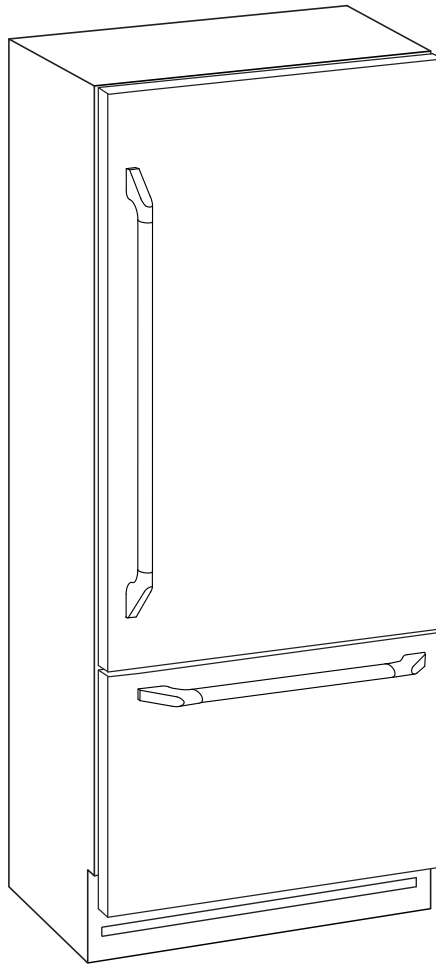

Style varies, model DYF36BFBSR shown

Table of Contents

Important Safety Instructions	1
Getting to Know Your Refrigerator.....	3
Operation	5
Care and Cleaning	21
Before You Call for Service	24
Warranty and Service	28
Warranty Card	Back Cover



To Our Valued Customer:

Congratulations on your purchase of the very latest in Dacor® products! Our unique combination of features, style and performance make us The Life of the Kitchen™, and a great addition to your home.

In order to familiarize yourself with the controls, functions and full potential of your new Distinctive Appliance, read this use and care manual thoroughly, beginning with the **Important Safety Instructions** section.

All Dacor appliances are designed and manufactured with quality and pride, while working within the framework of our company value. Should you ever experience a problem with your product, please first check the **Before You Call for Service** section of this manual for guidance. It provides useful suggestions and remedies prior to calling for service.

Valuable customer input helps us to continuously improve our products and services, so please feel free to contact our Customer Service Team for assistance with any of your product support needs.

Dacor Customer Service Team
14425 Clark Avenue
City of Industry, CA 91745

Telephone: (800) 793-0093
Fax: (626) 403-3130
Hours of Operation: Monday through Friday
6:00 A.M. to 5:00 P.M. Pacific Time

Web Site: www.dacor.com

Thank you for choosing Dacor for your home. We are a company built by families for families and we are dedicated to serving yours. We are confident that your new Dacor product will deliver a high level of performance and enjoyment for many years to come.

Sincerely,

The Dacor Customer Service Team

Important Safety Instructions

INSTALLER: Leave these instructions with the appliance.

CUSTOMER: Read this use and care manual completely before using your appliance. Save it for future reference. Retain your sales receipt or canceled check. Proof of original purchase date is required for warranty service.

For warranty and service information, see page 10.

If you have any questions, call:

Dacor Customer Service
(800) 793-0093 (U.S.A. and Canada)
Monday — Friday 6:00 A.M. to 5:00 P.M. Pacific Time

Web site: www.dacor.com

Have the complete model and serial number identification for your appliance ready. These numbers are found on the label under the freezer drawer face, at the bottom of the refrigerator, as shown. Record these numbers below for easy access.

Model number _____

Serial number _____

Date of purchase _____

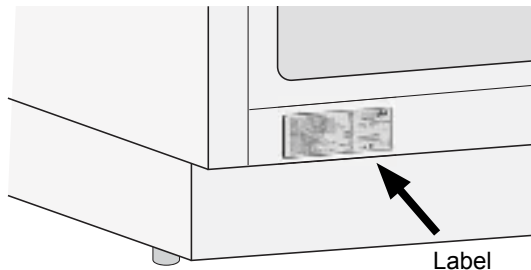

Since we continually improve the quality and performance of our products, we may make changes to the appliance without updating this manual. Visit www.dacor.com to download the latest version of this manual.

About Safety Instructions

The **Important Safety Instructions** and warnings in this manual are not meant to cover all possible problems and situations that can occur. Use common sense and caution when installing, maintaining or operating this or any other appliance.

Always contact the Dacor Customer Service Team about problems or situations that you do not understand.

Safety Symbols and Labels

DANGER

DANGER – Immediate hazards that **WILL** result in severe personal injury or death.

WARNING

WARNING – Hazards or unsafe practices that **COULD** result in severe personal injury or death.

CAUTION

CAUTION – Hazards or unsafe practices that **COULD** result in minor personal injury or property damage.

DANGER

IMPORTANT: To prevent child entrapment and suffocation when discarding an old appliance:

- Take off the door(s).
- Leave the racks in place so children cannot easily climb inside.
- Cut the prongs off the power plug and discard them.
- Cut the power cable off and discard it separately from the old appliance.

IMPORTANT: To avoid the possibility of explosion or fire, do not store or use combustible, flammable or explosive vapors and liquids (such as gasoline) inside or in the vicinity of this or any other appliance.

WARNING

IMPORTANT: This appliance is equipped with a three prong grounding electric plug for protection against possible electric shock hazards. It must be plugged into a dedicated, grounded, electrical outlet. If only a two prong electrical outlet is available, it is the responsibility of the customer to have it replaced with a dedicated, properly grounded three prong electrical outlet.

- **DO NOT** cut or remove the third (ground) prong from the power cord.
- **DO NOT** use an adapter plug.
- **DO NOT** use a power cord that is frayed or damaged.
- **DO NOT** connect the appliance to an extension cord.
- Keep the power cord away from heated surfaces.

NOTE: Use of an electrical outlet with a ground fault interrupter (GFI) is not recommended.

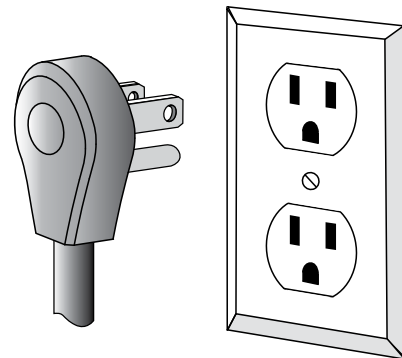

Power cord with three prong grounding plug

Grounded type electrical outlet

State of California Proposition 65 Warnings:

WARNING: This product contains one or more chemicals known to the State of California to cause cancer.

WARNING: This product contains one or more chemicals known to the State of California to cause birth defects or other reproductive harm.

READ AND SAVE THESE INSTRUCTIONS

Important Safety Instructions

General Safety Precautions

WARNING - To reduce the risk of fire, electric shock, serious injury or death when using your appliance, follow basic safety precautions, including the following:

WARNING

- If you receive a damaged product, immediately contact your dealer or builder. Do not install or use a damaged appliance.
- Make sure that this appliance has been properly installed according to the accompanying installation instructions. Make sure you know the location of the electrical outlet so that you know where and how to disconnect power. Making sure the appliance is properly installed is the responsibility of the customer.
- Refrigeration equipment must be properly disposed of in a professional and appropriate way, in accordance with the current local regulations and laws which protect the environment. This applies to your old appliance and to your new unit once it has reached the end of its service life. DO NOT dispose of the appliance in a landfill or with urban waste. Contact local waste disposal centers for information on how to dispose of recyclable waste.
- Take care when handling, moving, using or disposing of the appliance to avoid damaging the refrigerant tubing or system.
- Do not install or use outdoors or in wet conditions. This appliance is not designed for installation in a recreational vehicle or boat.
- Keep packaging materials away from children. Plastic sheets and bags can cause suffocation.
- Connect this appliance to a 115 Vac, 15 Amp. circuit that is controlled by a circuit breaker or fuse. This appliance should have its own separate grounded circuit.
- Do not kink or pinch the power supply cord of the appliance. Never unplug the appliance by pulling on the power cord. Always grip the plug firmly and pull straight out from the electrical outlet.
- Disconnect this appliance when not in use.
- Do not install, repair, modify or replace any part of the appliance unless specifically recommended in the literature accompanying it. A qualified service technician should perform all other service.
- Before installing or performing any type of service, disconnect the unit from the electrical outlet or disconnect power at the circuit breaker panel or fuse box.
- Use this appliance only for its intended purpose, the storage of food and beverages. It is not intended for commercial or industrial use.
- This appliance is not intended for use by persons (including children) with reduced physical, sensory or lack of experience and knowledge unless they are properly supervised by a person responsible for their safety. Children must be supervised to ensure that they do not play with the appliance.
- Never allow anyone, including children to sit, stand or climb on any part of the appliance, including the door. Doing so may cause damage, serious injury or death.
- If the power cord is damaged, it must be replaced by the manufacturer or a qualified service technician in order to avoid a safety hazard.
- Do not tamper with the controls.

WARNING

- Clean this appliance regularly as instructed in the **Care and Cleaning** section of this manual. Clean the ice container regularly.
- The appliance features a lighting system with high intensity LED lamps. Do not stare into these lamps when they are on to avoid possible eyesight damage.
- When the freezer is functioning, do not touch the inner stainless steel surfaces with wet or damp hands, since skin may stick to the very cold surfaces.
- Do not use any type of electrical equipment inside the refrigerator or freezer compartments.
- When positioning the shelves, do not place fingers in the shelf slides.

CAUTION

- In the event of a power outage, minimize opening the door.
- Do not obstruct any of the vents or openings on the appliance.

Getting to Know Your Refrigerator

A Stainless steel structure with aluminum trim

B Control panel

C Water filter

D Adjustable shelves

E Vegetable drawer

F Deli drawer

G Automatic ice maker

H Automatic drawer closing system

J Dual refrigeration system

K Control panel display

L Adjustable door shelves

M Door with self closing hinges

N LED lighting

P FreshZone freezer compartment that can also be set to act as a refrigerator or “fresh” compartment; see pages 5 and 15. When the appliance is first switched on the FreshZone compartment is set to the freezer mode.

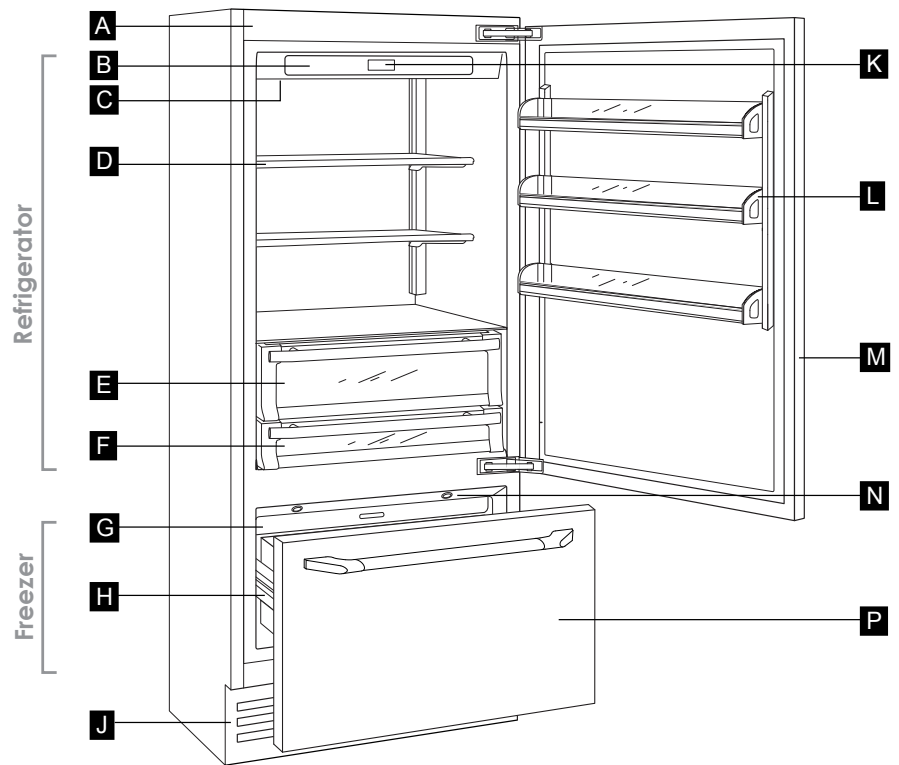

Bottom Grill Models

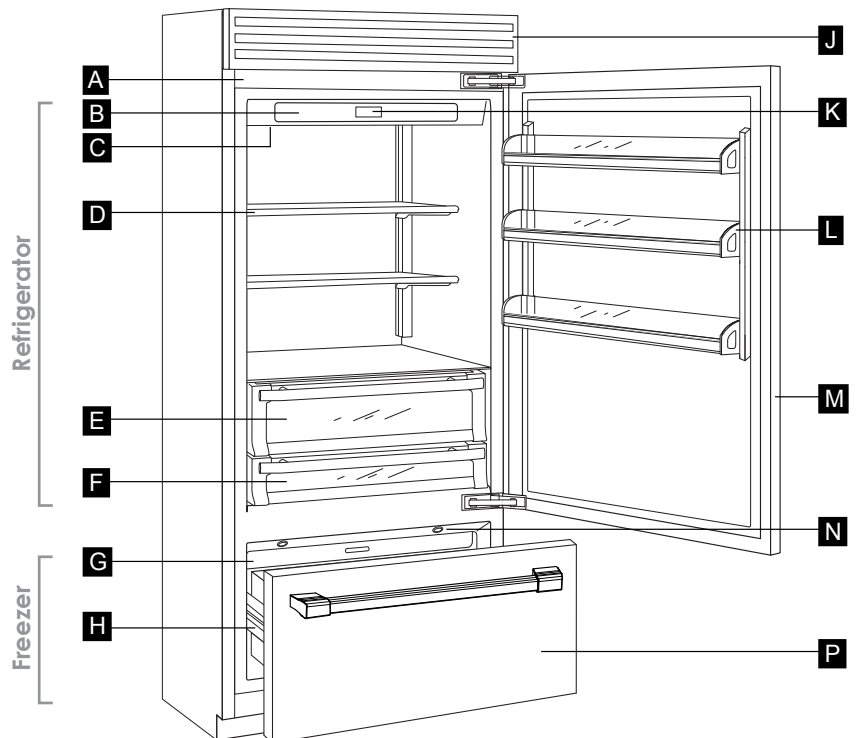

Top Grill Models

Getting to Know Your Refrigerator

Control Panel

The electronic control system on your Dacor refrigerator maintains constant temperature in both compartments and displays the measured temperature on the control panel. It also allows the user to personalize settings of the various functions and alerts the user should a malfunction occur.



ON/OFF

Switches the appliance (all compartments) between ON and Stand by (Tap for three seconds).

FRIDGE

Allows you to switch off the refrigerator compartment and leave the FreshZone freezer compartment on (Tap for three seconds).

MENU

Allows access to the control panel menu to change the appliances various settings. See page 7 for more details.

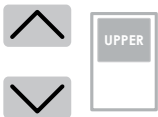

Up/Down - refrigerator: Tap the refrigerator Up and Down keys, to change the refrigerator temperature setting or to navigate through the control panel menu.



Display: Shows the temperature of the refrigerator and freezer compartments, the date and time, control panel menu and various other messages.*

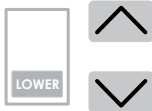

Up/Down - freezer (FreshZone): Tap the freezer Up and Down keys, to change the FreshZone freezer compartment temperature setting.

SELECT

Tap to confirm selections made in the control panel menu.

ICE

Tap to turn the ice maker on or off.

ALARM

Flashes to signal user alerts such as door being left open in combination with a warning tone. Tap this key to deactivate the warning tone.

*During operation, various messages will appear on the display. See page 24 for a more complete description.

Operation

Unlocking the Keypad

Anytime the appliance is turned on and the control panel has not been used for a while, the keypad locks automatically. To unlock the keypad, Tap the **MENU** and refrigerator ∇ (down) keys together for three seconds as shown below.

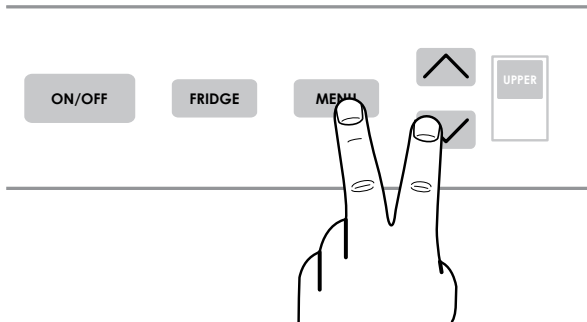

Keypad Unlock Procedure

Switching On and Off

When the appliance is connected to the electrical outlet for the first time, but has not yet been switched on, **Stand by** appears on the display. This is a safety message indicating that the appliance is connected to power but is not turned on.



- To turn on the appliance, Tap the **ON/OFF** key for three seconds.
- To turn off the appliance, Tap the **ON/OFF** key for three seconds again.

Each time the appliance is switched on (or experiences a power failure) it goes through an **Initial Test** procedure lasting about three minutes. Following the initial test, **Start Up Phase** may appear on the display as the unit begins to cool down.



IMPORTANT

After a prolonged interruption of electrical power, an audible signal will indicate if the temperature is above normal levels. In addition, the display will show for one minute the highest temperature detected inside the compartments, to allow the user to decide how to best use the food inside. After one minute the display will resume normal operation, while the **ALARM** key will continue to blink. After the alarm stops sounding, Tap the **ALARM** key to display the highest recorded temperatures.

Switching Off Refrigerator Only

- The **FRIDGE** key allows you to switch off the refrigerator compartment and leave the FreshZone™ freezer compartment on. Touch the **FRIDGE** key for three seconds to deactivate the refrigerator. The FreshZone freezer compartment can only be switched off completely by switching off the appliance completely using the **ON/OFF** key (the refrigerator compartment will go off too).
- If the refrigerator compartment is switched off, the refrigerator compartment lights will go off and the fan may continue to operate to prevent the formation of unpleasant odors and mold.

- Touch the **FRIDGE** key again for three seconds to turn the refrigerator compartment back on. Allow at least 6 hours for the refrigerator compartment to cool to operating temperature.

Temperature Adjustment

- The refrigerator and FreshZone freezer sections are pre-set at the factory to the optimal temperature settings. Usually, it is not necessary to modify the settings. Allow at least 6 hours to reach a new selected temperature.
- The refrigerator and freezer temperatures normally displayed are the actual temperatures inside each compartment (unless the actual temperature is out of range of the control panel's display). The temperature shown can vary slightly with respect to the set temperature following frequent opening of the doors or inserting room temperature foods or large quantities of food.
- When you tap the \wedge (up) or ∇ (down) arrow key for the refrigerator or FreshZone freezer compartment, the current temperature setting will appear. Tapping the \wedge (up) or ∇ (down) keys additional times will then increase or decrease the temperature setting. The display will show the new setting for a few seconds, then return to the current temperature inside that compartment.

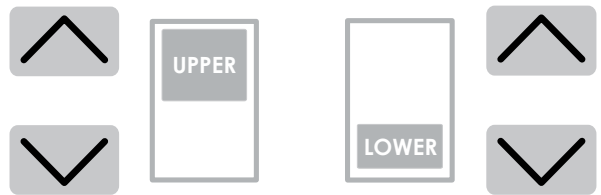

Refrigerator Compartment

FreshZone Freezer Compartment

Temperature Adjustment Keys

Setting the Refrigerator Temperature

1. Touch the **MENU** and refrigerator ∇ (down) keys together for three seconds, as shown (above left), to unlock the keypad.
2. Tap the \wedge (up) or ∇ (down) arrow key next to the refrigerator (**UPPER**) symbol. The temperature range for the refrigerator compartment is from 34°F to 46°F (+1°C to +7°C).

Setting the FreshZone Freezer Compartment Temperature

1. Touch the **MENU** and refrigerator ∇ (down) keys together for three seconds, as shown (above left), to unlock the keypad.
 2. Tap the \wedge (up) or ∇ (down) arrow key next to the freezer (**LOWER**) symbol.
- The temperature range for the FreshZone freezer compartment is -11°F to 9°F (-23°C to -13°C), except when the freezer is set to the "fresh" or refrigerator temperature range using the FreshZone feature (see page 15).
 - Temperature range when freezer section is set to "fresh" using the FreshZone feature: 28°F to 36°F (-2°C to +2°C).
 - Temperature range when freezer section is set to refrigerator using the FreshZone feature: 36°F to 48°F (+2°C to +8°C).

Operation

Ice Maker Operation

WARNING

- Failure to follow instructions regarding sanitizing can compromise the hygienic safety of the ice dispensed. Do not connect the refrigerator to a water supply that is microbiologically unsafe or of unknown quality without adequate disinfection. Systems certified for cyst reduction may be used on disinfected water that may contain filterable cysts.
- Do not activate the ice maker unless the water supply line is connected to the appliance and the water valve is on.
- Do not place hands or fingers near the ice maker when it is turned on.
- The filter must be changed when indicated on the control panel or when the ice maker has not been used for more than 30 days.
- When using the appliance for the first time and every time the filter is changed, discard the first container full of ice produced.
- Do not place any bottles or food in the ice cube container. The ice maker may become blocked or damaged.

5. Tap the **SELECT** and **ICE** keys at the same time until `Filter Reset OK` appears on the display.
6. Reinstall the glass panel by pushing it up into place until it stops, then pulling the plastic frame at the sides, toward you.
7. The ice container is located in the upper drawer of the freezer compartment. After removal, make sure to reposition it correctly, as shown.

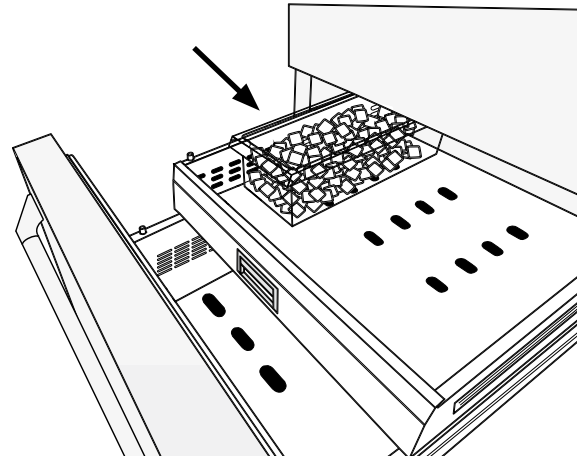

Using the Ice Maker for the First Time

1. Make sure the ice maker is off (the **ICE** key is not lit). If the ice maker is on, Tap the **ICE** key, located on the main control panel, until the light goes off.
2. Perform a manual clean. See page 14.
3. Open the glass panel inside the top of the refrigerator compartment by pushing up and back on both sides of the plastic frame surrounding it, then lowering it down.

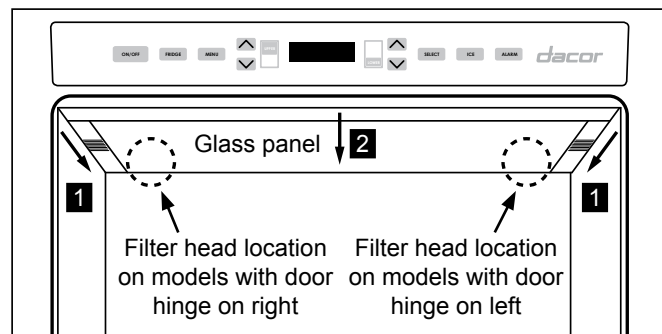

4. Remove the packaging on the supplied water filter cartridge and insert it into the filter head, located either to the right or left of the lighting system. Gently rotate the filter clockwise 1/4 turn, until it locks into place.

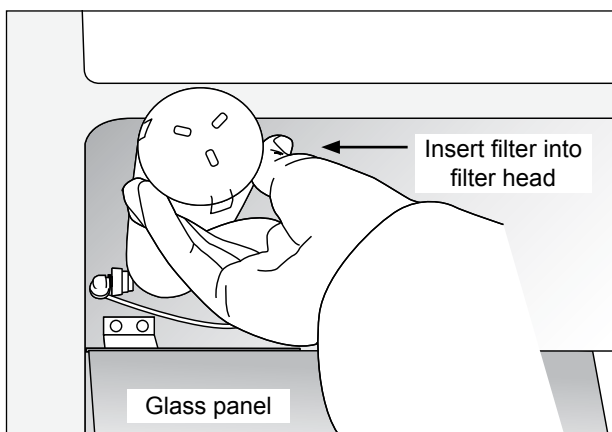

Ice Maker Operation

Tap the **ICE** key to turn ON or OFF. The button is lit when the ice maker is ON.

NOTES

- The ice maker will only produce ice with the FreshZone freezer compartment set to freezer mode.
- 12 to 24 hours are required after activation before ice production can begin. The ice maker normally produces 10 cubes per cycle, at approximately 10 cycles in 24 hours. The ice maker produces ice until the ice container is full and then stops. It restarts when ice cubes are removed.
- The yield may be reduced by a lower freezer temperature setting, higher room temperature or frequent door opening.
- The size of the ice cubes produced is adjustable. See **Set Cube Size** on page 12.
- Turn off the ice maker using the **ICE** key whenever the water supply valve is turned off.
- It is normal for some ice cubes to stick to one another.
- If the ice is not used frequently, it is best to empty the ice container once every 8-10 days. If the ice is not frequently used, the older cubes can become cloudy, and will have a strange flavor.
- Switch off the ice maker when removing the ice container.
- The ice maker automatically deactivates if Holiday Mode is activated.
- If the appliance has been switched off for a month or more, Dacor recommends performing a manual clean cycle (see page 14).
- Ice cubes which have been in the ice cube container for a long time may absorb odors. To prevent odors:
 - ◇ Clean the ice container periodically (see page 13).
 - ◇ Check the contents of the freezer for spoiled or out-of-date food regularly. Wrap all odorous foods thoroughly or store in airtight containers.
 - ◇ Change the water filter at recommended intervals (see page 23). Also check the quality of the water supply.

Operation

Shelf Adjustment

The two upper shelves in the refrigerator compartment and all the shelves in the door can be easily moved up or down as follows:

1. Lift the front of the shelf up.
2. While lifting the front up, push or pull the back of the shelf up or down to the desired position.
3. Lower the front down to the level position.

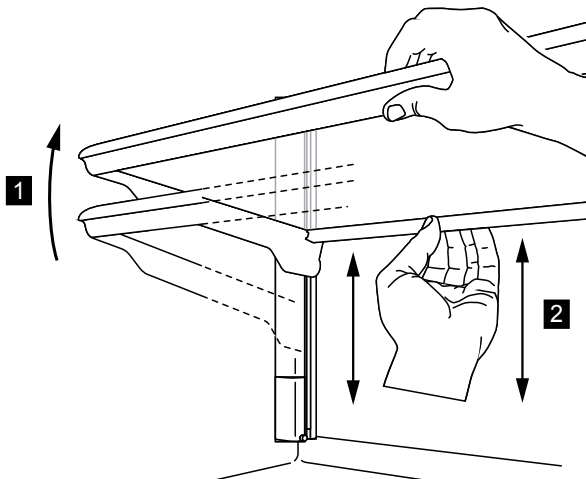

Shelf Adjustment - Refrigerator Compartment

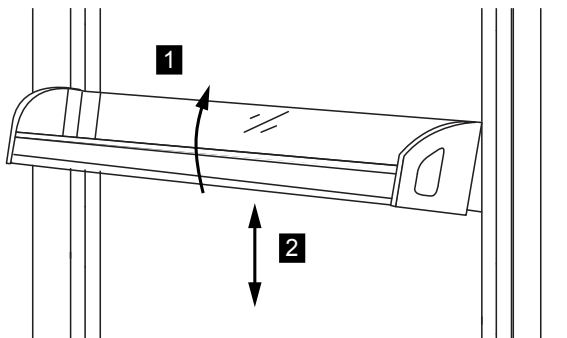

Shelf Adjustment - Door

Alarm

The alarm key is used to silence the alarm that accompanies certain messages that appear on the display. It can also be used to clear some error messages that appear on the display. When you tap the **ALARM** key, the tone will be silenced, but the key will continue to flash until the cause of the alarm has been resolved.

Display Messages

Various messages will appear on the display from time to time for various reasons. Messages that flash on and off indicate an error condition or malfunction. See the **Before You Call For Service** section on page 24 for a complete description of the various messages.

Vacation

- During long periods of absence, Dacor recommends that you switch off the refrigerator (see page 5) and disconnect the power cord or turn off power at the circuit breaker panel or fuse box. Before switching off the appliance, remove all of the items inside and leave the doors and drawers open to prevent the formation of unpleasant odors and mold.
- During shorter absences, you can put the appliance in Holiday Mode to save energy (see page 9).

Control Panel Functions/Settings

IMPORTANT

Adjustment of the control panel settings is not possible when the refrigerator is starting up for the first time. Changes made to the control panel settings may not be saved until the compartments have reached operating temperature.

Overview

- After unlocking the keypad (see page 5), tapping the **MENU** key activates the **Functions / Settings** adjustment menu. The **MENU** key is lit while the control panel menu is active.
- While the control panel menu is active, the **MENU**, **^** (up) or **∨** (down) and **SELECT** keys are used to navigate and set (confirm) the various functions and settings as outlined in the following sections.

NOTE

At any point in the menu, you can tap the **MENU** key to go back one screen, or repeatedly tap to return to the main display and exit the control panel menu. The **MENU** key light will shut off when you have exited the menu.

Max Cool Fridge

- The max cool function lowers the refrigerator compartment temperature to 35°F (+2°C) for several hours. It provides for more rapid cooling of large amounts of food that have just been placed inside and avoids the resulting rise in compartment temperature. The number of hours Max Cool operates is adjustable.
- Max Cool can be set to operate for up to 12 hours. Once the set number of hours has expired, the function deactivates, returning the compartment to the previously set temperature. In case of power failure, this function must be reactivated.

continued...

Operation

To activate Max Cool Fridge:

Tap MENU and refrigerator ∨ (down) to unlock keypad (if locked)	Key-pad Unlocked appears on display
Tap MENU	Functions appears on display
Tap SELECT	Max Cool Fridge appears on display
Tap SELECT	Max Cool ON/OFF appears on display
Tap SELECT	Max Cool Off appears on display
Tap ∨ (down)	Max Cool On appears on display
Tap SELECT	Max Cool ON/OFF appears on display
Tap MENU repeatedly until it is no longer lit.	Main display appears

To deactivate Max Cool Fridge:

Tap MENU and refrigerator ∨ (down) to un-lock keypad (if locked)	Key-pad Unlocked appears on display
Tap MENU	Functions appears on display
Tap SELECT	Max Cool Fridge appears on display
Tap SELECT	Max Cool ON/OFF appears on display
Tap SELECT	Max Cool On appears on display
Tap ∨ (down)	Max Cool Off appears on display
Tap SELECT	Max Cool ON/OFF appears on display
Tap MENU repeatedly until it is no longer lit.	Main display appears

To set Max Cool Fridge duration:

Tap MENU and refrigerator ∨ (down) to un-lock keypad (if locked)	Key-pad Unlocked appears on display
Tap MENU	Functions appears on display
Tap SELECT	Max Cool Fridge appears on display
Tap SELECT	Max Cool ON/OFF appears on display
Tap ∨ (down)	Max Cool Time appears on display
Tap SELECT	Set Hours appears on display
Tap ∧ (up) or ∨ (down) repeatedly until...	Desired Max Cool hours appear on display
Tap SELECT	Max Cool Time appears on display
Tap MENU repeatedly until it is no longer lit.	Main display appears

Max Cool FreshZone

- The Max Cool FreshZone function lowers the temperature of the FreshZone freezer compartment which provides for more rapid freezing/cooling of large amounts of food that have just been placed inside and avoiding the resulting rise in compartment temperature. The compartment will remain at this temperature for the number of hours set, then return to the set temperature.
- The temperature to which the compartment is lowered depends on the temperature range to which the FreshZone freezer compartment is set:
 - 9°F (-22°C) when set to freezer mode
 - 27°F (-2°C) when set to fresh mode
 - 35°F (+2°C) when set to refrigerator mode
- When the FreshZone freezer compartment is set to freezer or fresh, activate this function before inserting large amounts of room temperature food for proper results.
- Max Cool can be set to operate for up to 12 hours. Once the set number of hours have expired, the function deactivates, returning the compartment to the previously set temperature. In case of power failure, this function must be reactivated.

Operation

To activate Max Cool FreshZone:

Tap MENU and refrigerator ∇ (down) to un-lock keypad (if locked)	Key-pad Unlocked appears on display
Tap MENU	Functions appears on display
Tap SELECT	Max Cool Fridge appears on display
Tap ∇ (down) repeatedly until...	Max Cool FreshZone appears on display
Tap SELECT	Max Cool ON/OFF appears on display
Tap SELECT	Max Cool FreshZone Off appears on display
Tap ∇ (down)	Max Cool FreshZone On appears on display
Tap SELECT	Max Cool ON/OFF appears on display
Tap MENU repeatedly until it is no longer lit.	Main display appears

To deactivate Max Cool FreshZone:

Tap MENU and refrigerator ∇ (down) to un-lock keypad (if locked)	Key-pad Unlocked appears on display
Tap MENU	Functions appears on display
Tap SELECT	Max Cool Fridge appears on display
Tap ∇ (down) repeatedly until...	Max Cool FreshZone appears on display
Tap SELECT	Max Cool ON/OFF appears on display
Tap SELECT	Max Cool FreshZone On appears on display
Tap ∇ (down)	Max Cool FreshZone Off appears on display
Tap SELECT	Max Cool ON/OFF appears on display
Tap MENU repeatedly until it is no longer lit.	Main display appears

To set Max Cool FreshZone duration:

Tap MENU and refrigerator ∇ (down) to un-lock keypad (if locked)	Key-pad Unlocked appears on display
Tap MENU	Functions appears on display
Tap SELECT	Max Cool Fridge appears on display
Tap ∇ (down) repeatedly until...	Max Cool FreshZone appears on display
Tap SELECT	Max Cool ON/OFF appears on display
Tap ∇ (down)	Max Cool Time appears on display
Tap SELECT	Set Hours appears on display
Tap \wedge (up) or ∇ (down) repeatedly until...	Desired Max Cool hours appear on display
Tap SELECT	Max Cool Time appears on display
Tap MENU repeatedly until the light is off	Main display appears

Holiday Fridge

- In case of prolonged absences, in conjunction with the **Holiday FreshZone** function, this function allows considerable energy savings by raising the refrigerator compartment temperature to 57°F (+14°C), for the number of days set.
- Holiday mode can be set to operate for up to 90 days. Once the set number of days has expired, the function deactivates, returning the compartment to the previously set temperature.
- It remains active even if there is a power interruption.

To activate the Holiday Fridge function:

Tap MENU and refrigerator ∇ (down) to un-lock keypad (if locked)	Key-pad Unlocked appears on display
Tap MENU	Functions appears on display
Tap SELECT	Max Cool Fridge appears on display
Tap ∇ (down)	Holiday Fridge appears on display
Tap SELECT	Holiday ON/OFF appears on display
Tap SELECT	Holiday Fridge Off appears on display
Tap ∇ (down)	Holiday Fridge On appears on display
Tap SELECT	Holiday ON/OFF appears on display
Tap MENU repeatedly until it is no longer lit.	Main display appears

Operation

To deactivate the Holiday Fridge function:

Tap MENU and refrigerator ∨ (down) to un-lock keypad (if locked)	Key-pad Unlocked appears on display
Tap MENU	Functions appears on display
Tap SELECT	Max Cool Fridge appears on display
Tap ∨ (down)	Holiday Fridge appears on display
Tap SELECT	Holiday ON/OFF appears on display
Tap SELECT	Holiday Fridge On appears on display
Tap ∨ (down)	Holiday Fridge Off appears on display
Tap SELECT	Holiday ON/OFF appears on display
Tap MENU repeatedly until it is no longer lit.	Main display appears

To set Holiday Fridge duration:

Tap MENU and refrigerator ∨ (down) to un-lock keypad (if locked)	Key-pad Unlocked appears on display
Tap MENU	Functions appears on display
Tap SELECT	Max Cool Fridge appears on display
Tap ∨ (down).	Holiday Fridge appears on display
Tap SELECT	Holiday ON/OFF appears on display
Tap ∨ (down)	Holiday Time appears on display
Tap SELECT	Set Days appears on display
Tap ∧ (up) or ∨ (down) repeatedly until...	Desired number of days appears on display
Tap SELECT	Holiday Time appears on display
Tap MENU repeatedly until it is no longer lit.	Main display appears

Holiday FreshZone

- In case of prolonged absences, in conjunction with the **Holiday Fridge** function, this function allows considerable energy savings by raising the FreshZone freezer compartment temperature. The temperature to which the compartment is raised depends on the temperature range to which the FreshZone compartment is set:
 - 5°F (-15°C) when set to freezer mode
 - 35°F (2°C) when set to Fresh mode
 - 57°F (+14°C) when set to refrigerator mode
- Holiday mode can be set to operate for up to 90 days. Once the set number of days have expired, the function deactivates, returning the compartment to the previously set temperature.
- It remains active even if there is a power interruption.

To activate the Holiday FreshZone function:

Tap MENU and refrigerator ∨ (down) to un-lock keypad (if locked)	Key-pad Unlocked appears on display
Tap MENU	Functions appears on display
Tap SELECT	Max Cool Fridge appears on display
Tap ∨ (down) repeatedly until...	Holiday FreshZone appears on display
Tap SELECT	Holiday ON/OFF appears on display
Tap SELECT	Holiday FreshZone Off appears on display
Tap ∨ (down)	Holiday FreshZone On appears on display
Tap SELECT	Holiday ON/OFF appears on display
Tap MENU repeatedly until it is no longer lit.	Main display appears

Operation

To deactivate the Holiday FreshZone function:

Tap MENU and refrigerator ∇ (down) to un-lock keypad (if locked)	Key-pad Unlocked appears on display
Tap MENU	Functions appears on display
Tap SELECT	Max Cool Fridge appears on display
Tap ∇ (down) repeatedly until...	Holiday FreshZone appears on display
Tap SELECT	Holiday ON/OFF appears on display
Tap SELECT	Holiday FreshZone On appears on display
Tap ∇ (down)	Holiday FreshZone Off appears on display
Tap SELECT	Holiday ON/OFF appears on display
Tap MENU repeatedly until it is no longer lit.	Main display appears

To set Holiday FreshZone duration:

Tap MENU and refrigerator ∇ (down) to un-lock keypad (if locked)	Key-pad Unlocked appears on display
Tap MENU	Functions appears on display
Tap SELECT	Max Cool Fridge appears on display
Tap ∇ (down) repeatedly until...	Holiday FrshZone appears on display
Tap SELECT	Holiday ON/OFF appears on display
Tap ∇ (down)	Holiday Time appears on display
Tap SELECT	Set Days appears on display
Tap \wedge (up) or ∇ (down) repeatedly until...	Desired number of days appears on display
Tap SELECT	Holiday Time appears on display
Tap MENU repeatedly until it is no longer lit.	Main display appears

Beverage Cooler

This function can be activated when it is necessary to cool beverages quickly, by placing them inside the FreshZone freezer compartment. You can select a duration of 1 to 45 minutes. A tone will indicate when the optimal temperature has been reached. After removing the beverages, deactivate the tone by tapping the **ALARM** key.

To activate the Beverage Cooler function:

Tap MENU and refrigerator ∇ (down) to un-lock keypad (if locked)	Key-pad Unlocked appears on display
Tap MENU	Functions appears on display
Tap SELECT	Max Cool Fridge appears on display
Tap ∇ (down) repeatedly until...	Beverage Cooler appears on display
Tap SELECT	Set Cooling Time appears on display
Tap ∇ (down)	Cooler ON/OFF appears on display
Tap SELECT	Beverage Cooler Off appears on display
Tap ∇ (down)	Beverage Cooler On appears on display
Tap SELECT	Cooler ON/OFF appears on display
Tap MENU repeatedly until it is no longer lit.	Main display appears

To deactivate Beverage Cooler function:

Tap MENU and refrigerator ∇ (down) to un-lock keypad (if locked)	Key-pad Unlocked appears on display
Tap MENU	Functions appears on display
Tap SELECT	Max Cool Fridge appears on display
Tap ∇ (down) repeatedly until...	Beverage Cooler appears on display
Tap SELECT	Set Cooling Time appears on display
Tap ∇ (down)	Cooler ON/OFF appears on display
Tap SELECT	Beverage Cooler On appears on display
Tap ∇ (down)	Beverage Cooler Off appears on display
Tap SELECT	Cooler ON/OFF appears on display
Tap MENU repeatedly until it is no longer lit.	Main display appears

continued...

Operation

To set the Beverage Cooler duration:

Tap MENU and refrigerator ∇ (down) to un-lock keypad (if locked)	Key-pad Unlocked appears on display
Tap MENU	Functions appears on display
Tap SELECT	Max Cool Fridge appears on display
Tap ∇ (down) repeatedly until...	Beverage Cooler appears on display
Tap SELECT	Set Cooling Time appears on display
Tap SELECT	Current set time appears on display, for example: Set Time : 20
Tap ∇ (down) or \wedge (up) until desired set time appears on display	For example Set Time : 10 appears on display
Tap SELECT	Set Cooling Time appears on display
Tap MENU repeatedly until it is no longer lit.	Main display appears

Ice Maker - Cube Size Function

The Ice Maker Cube Size function permits selecting the size of the ice cubes. Choose large (default setting) or medium size ice cubes.

To set ice cube size:

Tap MENU and refrigerator ∇ (down) to un-lock keypad (if locked)	Key-pad Unlocked appears on display
Tap MENU	Functions appears on display
Tap SELECT	Max Cool Fridge appears on display
Tap ∇ (down) repeatedly until...	Ice Maker appears on display
Tap SELECT	Set Cube Size appears on display
Tap SELECT	Size Large or Size Med appears on display
Tap ∇ (down) to change size	New ice cube size appears on display
Tap SELECT	Set Cube Size appears on display
Tap MENU repeatedly until it is no longer lit.	Main display appears

Ice Maker - Fast Ice Function

The Fast Ice function increases the quantity of ice produced. It deactivates automatically after 24 hours.

To activate the Fast Ice function:

Tap MENU and refrigerator ∇ (down) to un-lock keypad (if locked)	Key-pad Unlocked appears on display
Tap MENU	Functions appears on display
Tap SELECT	Max Cool Fridge appears on display
Tap ∇ (down) repeatedly until...	Ice Maker appears on display
Tap SELECT	Set Cube Size appears on display
Tap ∇ (down)	Fast Ice ON/OFF appears on display
Tap SELECT	Fast Ice Off appears on display
Tap ∇ (down)	Fast Ice On appears on display
Tap SELECT	Fast Ice ON/OFF appears on display
Tap MENU repeatedly until it is no longer lit.	Main display appears

To deactivate the Fast Ice function:

Tap MENU and refrigerator ∇ (down) to un-lock keypad (if locked)	Key-pad Unlocked appears on display
Tap MENU	Functions appears on display
Tap SELECT	Max Cool Fridge appears on display
Tap ∇ (down) repeatedly until...	Ice Maker appears on display
Tap SELECT	Set Cube Size appears on display
Tap ∇ (down)	Fast Ice ON/OFF appears on display
Tap SELECT	Fast Ice Off appears on display
Tap ∇ (down)	Fast Ice On appears on display
Tap SELECT	Fast Ice ON/OFF appears on display
Tap MENU repeatedly until it is no longer lit.	Main display appears

Operation

Sabbath Mode

This function deactivates the lights and disables the door switches so that the operation of the unit is not affected by opening and closing of the door. The control panel keys remain active.

To activate the Sabbath mode:

Tap MENU and refrigerator ∨ (down) to un-lock keypad (if locked)	Key-pad Unlocked appears on display
Tap MENU	Functions appears on display
Tap SELECT	Max Cool Fridge appears on display
Tap ∨ (down) repeatedly until...	Set Sabbath Mode appears on display
Tap SELECT	Sabbath Mode Off appears on display
Tap ∨ (down)	Sabbath Mode On appears on display
Tap SELECT	Sabbath Mode ON appears on display

To deactivate the Sabbath mode:

Tap MENU and refrigerator ∨ (down) to un-lock keypad (if locked)	Key-pad Unlocked appears on display
Tap MENU	Functions appears on display
Tap SELECT	Max Cool Fridge appears on display
Tap ∨ (down) repeatedly until...	Set Sabbath Mode appears on display
Tap SELECT	Sabbath Mode On appears on display
Tap ∨ (down)	Sabbath Mode Off appears on display
Tap SELECT	Set Sabbath Mode appears on display
Tap MENU repeatedly until it is no longer lit.	Main display appears

Water Filter Status

This function allows you to view the time left before the filter needs to be replaced.

To view the filter status:

Tap MENU and refrigerator ∨ (down) to un-lock keypad (if locked)	Key-pad Unlocked appears on display
Tap MENU	Functions appears on display
Tap SELECT	Max Cool Fridge appears on display
Tap ∨ (down) repeatedly until...	Water Filter appears on display
Tap SELECT	Status Filter appears on display
Tap SELECT	View Status appears on display
Tap SELECT	Amount of filter capacity remaining appears on display
Tap MENU repeatedly until it is no longer lit.	Main display appears

Water Filter Reset

The Water Filter Reset function sets the filter time remaining on the Water Filter Status display to zero. Set the remaining filter time back to zero each time the filter is replaced.

To reset the remaining filter time:

Touch and hold both the **SELECT** and **ICE** keys until **Filter Reset OK** appears on the display, or perform the following steps...

Tap MENU and refrigerator ∨ (down) to un-lock keypad (if locked)	Key-pad Unlocked appears on display
Tap MENU	Functions appears on display
Tap SELECT	Max Cool Fridge appears on display
Tap ∨ (down) repeatedly until...	Water Filter appears on display
Tap SELECT	Status Filter appears on display
Tap SELECT	View Status appears on display
Tap ∨ (down)	Filter Reset appears on display
Tap SELECT	Select to Confirm appears on display
Tap SELECT	Filter Reset appears on display
Tap MENU repeatedly until it is no longer lit.	Main display appears

Operation

Water Filter Bypass

Activate this function when good quality water is being supplied to the refrigerator and the internal water filter is not necessary. An example would be when a whole house water filter is in use.

To activate the filter bypass function:

Tap MENU and refrigerator ∨ (down) to un-lock keypad (if locked)	Key-pad Unlocked appears on display
Tap MENU	Functions appears on display
Tap SELECT	Max Cool Fridge appears on display
Tap ∨ (down) repeatedly until...	Water Filter appears on display
Tap SELECT	Status Filter appears on display
Tap ∨ (down) repeatedly until...	Filter Bypass appears on display
Tap SELECT	Filter Bypass Off appears on display
Tap ∨ (down)	Filter Bypass On appears on display
Tap SELECT	Filter Bypass appears on display
Tap MENU repeatedly until it is no longer lit.	Main display appears

To deactivate the filter bypass function:

Tap MENU and refrigerator ∨ (down) to un-lock keypad (if locked)	Key-pad Unlocked appears on display
Tap MENU	Functions appears on display
Tap SELECT	Max Cool Fridge appears on display
Tap ∨ (down) repeatedly until...	Water Filter appears on display
Tap SELECT	Status Filter appears on display
Tap ∨ (down) repeatedly until...	Filter Bypass appears on display
Tap SELECT	Filter Bypass On appears on display
Tap ∨ (down)	Filter Bypass Off appears on display
Tap SELECT	Filter Bypass appears on display
Tap MENU repeatedly until it is no longer lit.	Main display appears

Manual Clean - Water Filter

- If the ice maker has been turned off or unused for a long period of time, or just before replacing the water filter, perform a Manual Clean to flush out water in the system before using the ice maker again.
- Before starting the process, make sure that the ice container or another suitable container is placed under the ice maker to collect the water, then close the drawer. At the end of the operation, wash the ice container, then put it back in place.

To clean the ice maker's internal water supply:

Tap MENU and refrigerator ∨ (down) to un-lock keypad (if locked)	Key-pad Unlocked appears on display
Tap MENU	Functions appears on display
Tap SELECT	Max Cool Fridge appears on display
Tap ∨ (down) repeatedly until...	Water Filter appears on display
Tap SELECT	Status Filter appears on display
Tap ∨ (down)	Manual Clean appears on display
Tap SELECT	Please wait... appears on display
When Select to Confirm appears on display	Tap SELECT
When process is complete, Tap MENU repeatedly until it is no longer lit.	Main display appears

Operation

FreshZone Setting

The freezer compartment can, if required, be converted to the refrigeration or “fresh” operation. See page 5 for refrigeration and “fresh” temperature ranges.

To change the FreshZone freezer compartment temperature range:

Tap MENU and refrigerator ∇ (down) to un-lock keypad (if locked)	Key-pad Unlocked appears on display
Tap MENU	Functions appears on display
Tap ∇ (down)	Settings appears on display
Tap SELECT	FreshZone Options appears on display
Tap SELECT	The current FreshZone compartment setting appears on display
Tap ∇ (down) repeatedly until...	The desired compartment setting appears on display (Freezer/Fridge/Fresh)
Tap SELECT	Select to Confirm appears on display
Tap SELECT	FreshZone Options appears on display
Tap MENU repeatedly until it is no longer lit.	Main display appears

Default Settings

Use this feature to change the appliance back to the settings entered at the factory.



IMPORTANT

If the unit is restored to the factory default settings, the FreshZone freezer compartment will be restored to freezer mode. If the FreshZone compartment was previously being used in fridge or “fresh” mode, be sure to set it back to the desired setting.

To change the appliance back to the factory default settings:

Tap MENU and refrigerator ∇ (down) to un-lock keypad (if locked)	Key-pad Unlocked appears on display
Tap MENU	Functions appears on display
Tap ∇ (down)	Settings appears on display
Tap SELECT	FreshZone Options appears on display
Tap ∇ (down)	Default Settings appears on display
Tap SELECT	Select to Confirm appears on display

Tap **SELECT**

Default Settings appears on display

Tap **MENU** repeatedly until it is no longer lit.

Main display appears

Date Setting

To set the date shown on the display:

Tap MENU and refrigerator ∇ (down) to un-lock keypad (if locked)	Key-pad Unlocked appears on display
Tap MENU	Functions appears on display
Tap ∇ (down)	Settings appears on display
Tap SELECT	FreshZone Options appears on display
Tap ∇ (down) repeatedly until...	Date appears on display
Tap SELECT	Set Date appears on display
Tap SELECT	The current date setting appears, for example DATE : 01-15-15 appears on display
Tap \wedge (up) or ∇ (down) repeatedly until...	Desired month appears on display, then Tap SELECT
Tap \wedge (up) or ∇ (down) repeatedly until...	Desired day appears on display, then Tap SELECT
Tap \wedge (up) or ∇ (down) repeatedly until...	Desired year appears on display
Tap SELECT	Set Date appears on display
Tap MENU repeatedly until it is no longer lit.	Main display appears

Operation

Disable Date on Display

To set the display so that the date is not shown:

Tap MENU and refrigerator ∇ (down) to un-lock keypad (if locked)	Key-pad Unlocked appears on display
Tap MENU	Functions appears on display
Tap ∇ (down)	Settings appears on display
Tap SELECT	FreshZone Options appears on display
Tap ∇ (down) repeatedly until...	Date appears on display
Tap SELECT	Set Date appears on display
Tap ∇ (down)	Show Date appears on display
Tap SELECT	DATE: 01-15-15 On appears on display
Tap ∇ (down)	DATE: 01-15-15 Off appears on display
Tap SELECT	Show Date appears on display
Tap MENU repeatedly until it is no longer lit.	Main display appears

To reactivate the display date when it is off:

Tap MENU and refrigerator ∇ (down) to un-lock keypad (if locked)	Key-pad Unlocked appears on display
Tap MENU	Functions appears on display
Tap ∇ (down)	Settings appears on display
Tap SELECT	FreshZone Options appears on display
Tap ∇ (down) repeatedly until...	Date appears on display
Tap SELECT	Set Date appears on display
Tap ∇ (down) repeatedly until...	Show Date appears on display
Tap SELECT	DATE: 01-15-15 Off appears on display
Tap ∇ (down)	DATE: 01-15-15 On appears on display
Tap SELECT	Show Date appears on display
Tap MENU repeatedly until it is no longer lit.	Main display appears

Time Setting

To set the time shown on the display:

Tap MENU and refrigerator ∇ (down) to un-lock keypad (if locked)	Key-pad Unlocked appears on display
Tap MENU	Functions appears on display
Tap ∇ (down)	Settings appears on display
Tap SELECT	FreshZone Options appears on display
Tap ∇ (down) repeatedly until...	Time appears on display
Tap SELECT	Set Time appears on display
Tap SELECT	The current time setting appears, for example Time: 01:23 appears on display
Tap \wedge (up) or ∇ (down) repeatedly until...	Desired hour appears on display, then Tap SELECT
Tap \wedge (up) or ∇ (down) repeatedly until...	Desired minute appears on display
Tap SELECT	Set Time appears on display
Tap MENU repeatedly until it is no longer lit.	Main display appears

Operation

Disable Time on Display

To set the display so that the time is not shown:

Tap MENU and refrigerator ∇ (down) to un-lock keypad (if locked)	Key-pad Unlocked appears on display
Tap MENU	Functions appears on display
Tap ∇ (down)	Settings appears on display
Tap SELECT	FreshZone Options appears on display
Tap ∇ (down) repeatedly until...	Time appears on display
Tap SELECT	Set Time appears on display
Tap ∇ (down)	Show Time appears on display
Tap SELECT	Time: 01:23 On appears on display
Tap ∇ (down)	Time: 01:23 Off appears on display
Tap SELECT	Show Date appears on display
Tap MENU repeatedly until it is no longer lit.	Main display appears

To reactivate the display time when it is off:

Tap MENU and refrigerator ∇ (down) to un-lock keypad (if locked)	Key-pad Unlocked appears on display
Tap MENU	Functions appears on display
Tap ∇ (down)	Settings appears on display
Tap SELECT	FreshZone Options appears on display
Tap ∇ (down) repeatedly until...	Time appears on display
Tap SELECT	Set Time appears on display
Tap ∇ (down)	Show Time appears on display
Tap SELECT	Time: 01:23 Off appears on display
Tap ∇ (down)	Time: 01:23 On appears on display
Tap SELECT	Show Time appears on display
Tap MENU repeatedly until it is no longer lit.	Main display appears

12/24HR Time Setting

The appliance is set to 12-hour (non-military) time at the factory. 24 hour time is also known as military time. 1:36 PM = 13:36 military time.

To change the 12/24HR time format:

Tap MENU and refrigerator ∇ (down) to un-lock keypad (if locked)	Key-pad Unlocked appears on display
Tap MENU	Functions appears on display
Tap ∇ (down)	Settings appears on display
Tap SELECT	FreshZone Options appears on display
Tap ∇ (down) repeatedly until...	Time appears on display
Tap SELECT	Set Time appears on display
Tap ∇ (down) repeatedly until...	Set View appears on display
Tap SELECT	Set 12 or Set 24 appears on display
Tap ∇ (down) until	Desired setting appears on display
Tap SELECT	Set View appears on display
Tap MENU repeatedly until it is no longer lit.	Main display appears

Setting the Language on the Display

To change the language:

Tap MENU and refrigerator ∇ (down) to un-lock keypad (if locked)	Key-pad Unlocked appears on display
Tap MENU	Functions appears on display
Tap ∇ (down)	Settings appears on display
Tap SELECT	FreshZone Options appears on display
Tap ∇ (down) repeatedly until...	Language appears on display
Tap SELECT	Current language appears on display
Tap ∇ (down) repeatedly until...	Desired language scale appears on display
Tap SELECT	Language appears on display
Tap MENU repeatedly until it is no longer lit.	Main display appears

Operation

Setting the Temperature Scale

You can select the temperature scale (Fahrenheit or Celsius) the appliance uses to display the cooling temperatures. It is preset at the factory to Fahrenheit.

To change the temperature scale:

Tap MENU and refrigerator ∇ (down) to un-lock keypad (if locked)	Key-pad Unlocked appears on display
Tap MENU	Functions appears on display
Tap ∇ (down)	Settings appears on display
Tap SELECT	FreshZone Options appears on display
Tap ∇ (down) repeatedly until...	Select °F/°C appears on display
Tap SELECT	Current temperature scale appears on display
Tap ∇ (down) repeatedly until...	Desired temperature scale appears on display
Tap SELECT	Select °F/°C appears on display
Tap MENU repeatedly until it is no longer lit.	Main display appears

Keypad Lock - Control Panel

To disable the control panel keypad lock:

Tap MENU and refrigerator ∇ (down) to un-lock keypad (if locked)	Key-pad Unlocked appears on display
Tap MENU	Functions appears on display
Tap ∇ (down)	Settings appears on display
Tap SELECT	FreshZone Options appears on display
Tap ∇ (down) repeatedly until...	Keypad Lock appears on display
Tap SELECT	Keypad Lock On appears on display
Tap ∇ (down)	Keypad Lock Off appears on display
Tap SELECT	Keypad Lock appears on display
Tap MENU repeatedly until it is no longer lit.	Main display appears

To re-enable the control panel keypad lock:

Tap MENU and refrigerator ∇ (down) to un-lock keypad (if locked)	Key-pad Unlocked appears on display
Tap MENU	Functions appears on display
Tap ∇ (down)	Settings appears on display
Tap SELECT	FreshZone Options appears on display
Tap ∇ (down) repeatedly until...	Keypad Lock appears on display
Tap SELECT	Keypad Lock Off appears on display
Tap ∇ (down)	Keypad Lock On appears on display
Tap SELECT	Keypad Lock appears on display
Tap MENU repeatedly until it is no longer lit.	Main display appears

Operation

Control Panel Menu Map

Functions Menu

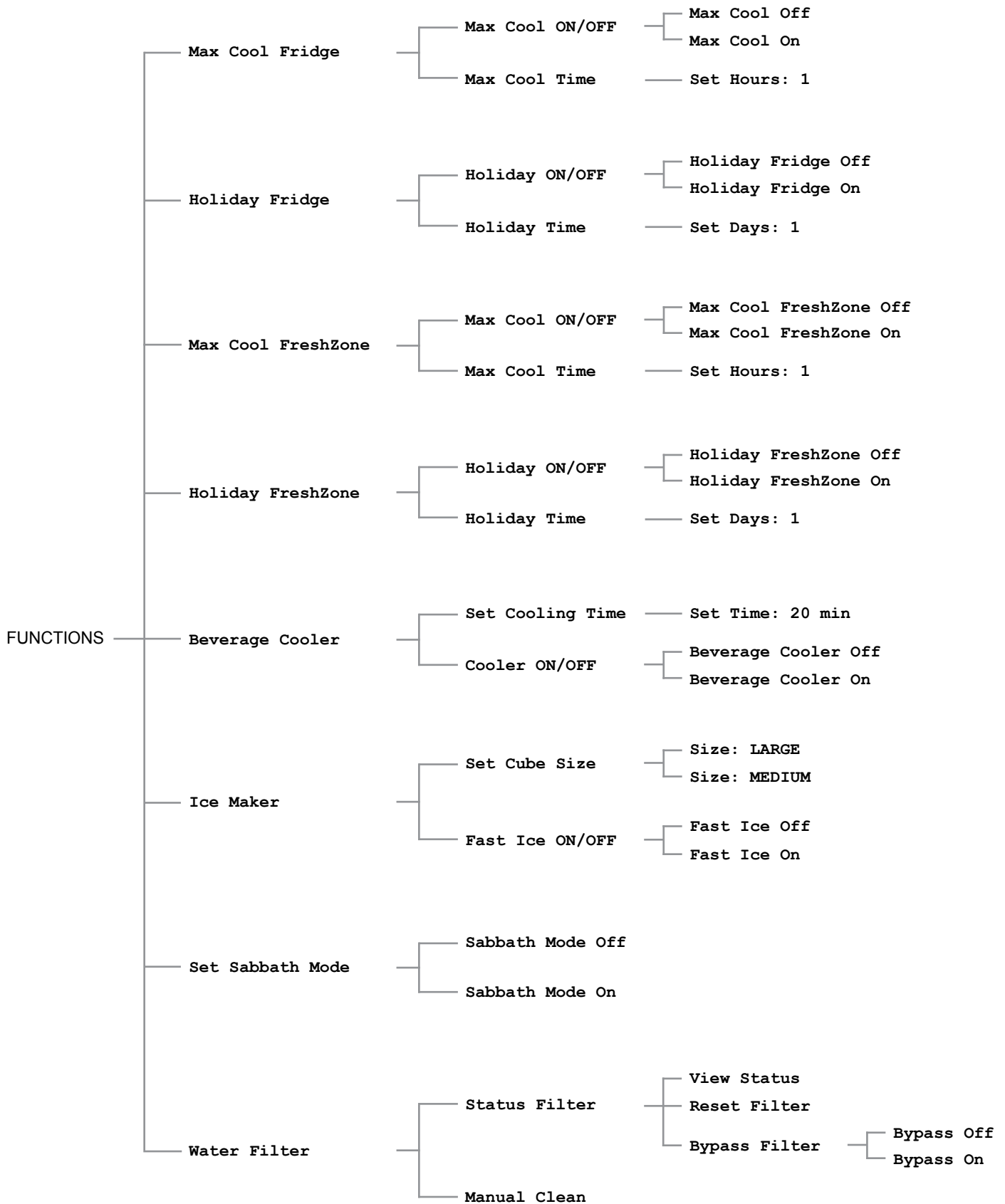

Operation

Control Panel Menu Map (cont.)

Settings Menu

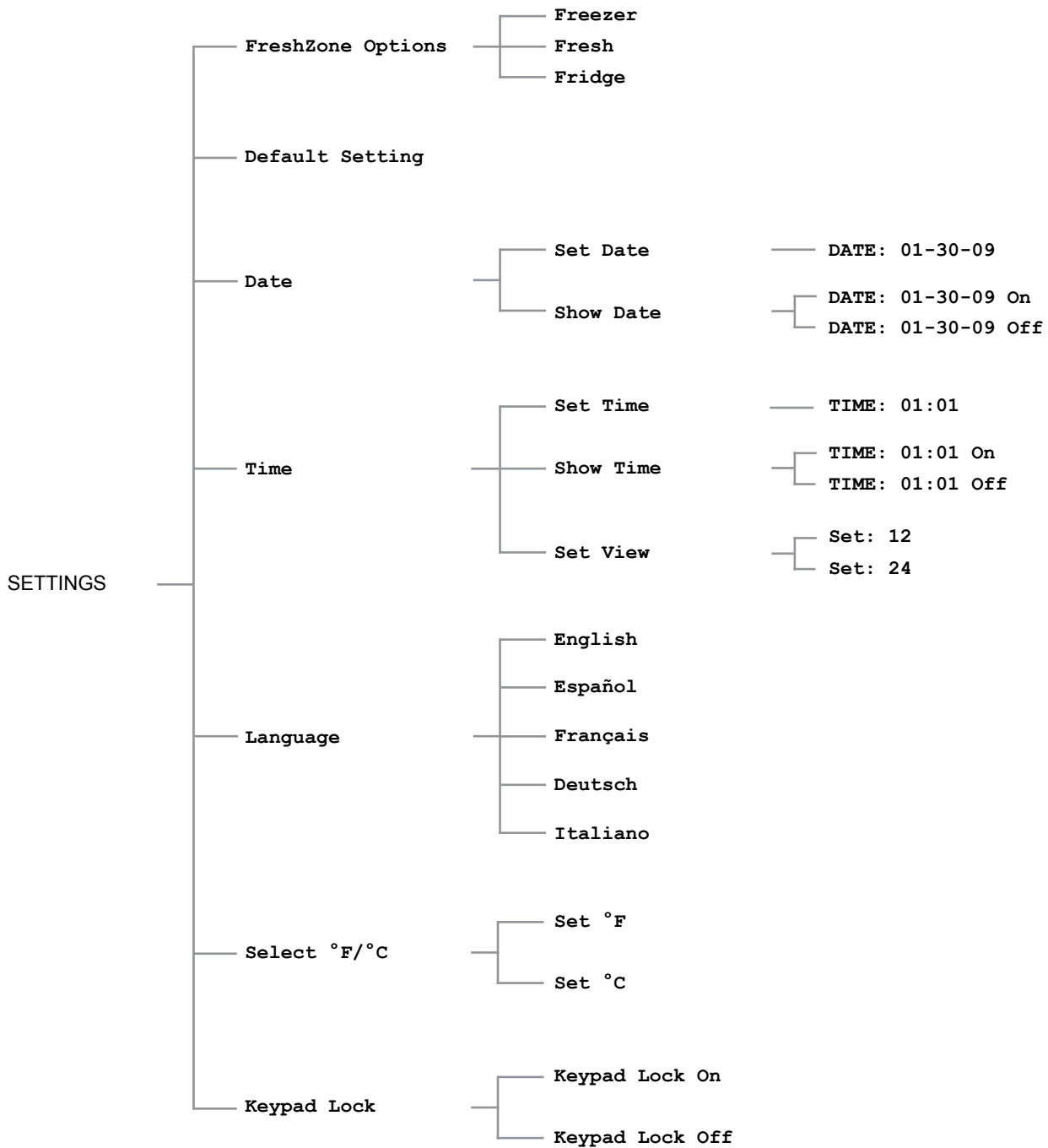

Care and Cleaning

General Cleaning

WARNING

- Before performing any sort of cleaning, disconnect the appliance from the electrical outlet.
- Clean this appliance only in the manner instructed.
- The edges of the condenser are sharp. Use adequate protection for hands and arms when cleaning it.
- Use only nonflammable, non-corrosive cleaners. Failure to do so can result in explosion, fire or death.
- Never use abrasive or metallic products which could scratch and damage the finishes permanently.
- Make sure you do not damage the refrigeration system in any way.
- Always wipe metallic finishes in the direction of the grain.
- Do not use the sponge on aluminium parts, such as the edges of the glass shelves.
- Do not use water on the electrical parts, lights and control panel.
- Do not bring cold glass parts into contact with boiling water.
- To prevent damage, do not wash any parts of the appliance in a dishwasher.
- Do not use mechanical devices or other methods to speed up defrosting.

Both the refrigerator and FreshZone freezer sections defrost automatically. Clean both sections once a month to avoid odor build-up. Wipe spills up immediately.

Cleaning the Exterior

1. To clean the parts made of steel use the micro-fiber cloth and the sponge provided with the appliance.
2. Every now and then, polish the steel, wipe with a slightly damp micro-fiber cloth.
3. Take special care to keep the ventilation openings in the appliance or inside the cabinet free of obstructions.

Ventilation Grill Cleaning/Removal

- Before cleaning and/or removing the ventilation grill, switch off the appliance by tapping the **ON/OFF** key on the main control panel for about 3 seconds. Removing the ventilation grill allows you to clean the back side.

Grill Removal - Top Grill Models

- The ventilation grill on top grill models is hinged for easy access, but cannot be completely removed. To access the back of the grill (and the condenser), grasp the bottom on both sides and pull out and up.

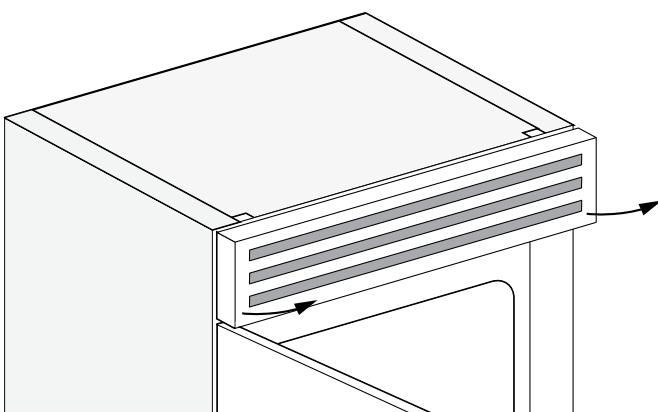

Grill Removal - Bottom Grill Models

- The ventilation grill on bottom grill models is held in place with magnets and is easy to remove. On some models, you may need to pull out the freezer drawer for easier access. To remove, grasp the grill and pull straight out.

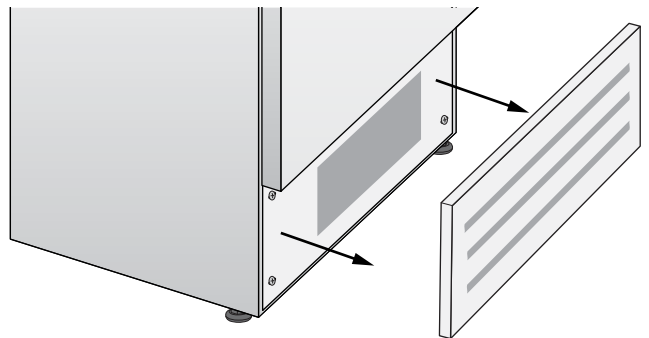

Cleaning the Ventilation Grill

- To clean the grill, use a vacuum cleaner with a soft brush attachment at maximum power, sweeping it along the vent slits. While the grill is removed, check the condition of the (finned) condenser and remove any dust, as instructed below.

Cleaning the Condenser

1. After the appliance is switched off and the ventilation grill removed, wait approximately 30 minutes for the (finned) condenser to cool down to room temperature.
2. Remove any dust build-up as shown in the picture. Use a vacuum cleaner with a soft brush attachment at maximum power, sweeping it back and forth in the direction of the fins, taking care not to bend any of them.

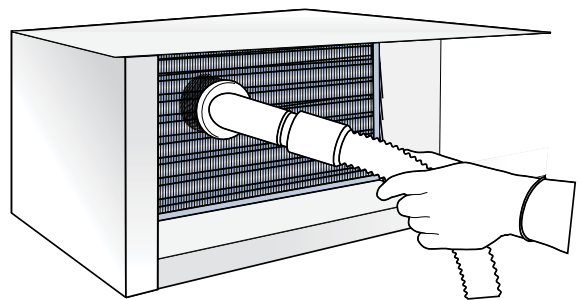

3. Start up the appliance again by tapping the **ON/OFF** key on the control panel for approximately 3 seconds.

Cleaning the Interior

1. Clean the internal parts by washing them with a solution of lukewarm water and a small amount of dishwashing detergent. See the following sections for instructions on how to disassemble removable parts.
2. Rinse and dry right away.
3. The ice cube container should be cleaned occasionally with warm water. Make sure that you switch off the ice maker before cleaning it. Rinse out and wipe dry.

Care and Cleaning

Shelf Removal

The shelves in the refrigerator compartment can be easily removed for cleaning as follows:

- To remove the two upper refrigerator compartment shelves, lift the front of each shelf up **1**, then push the rear of the shelf up in back **2** until it clears the shelf holders at the top.

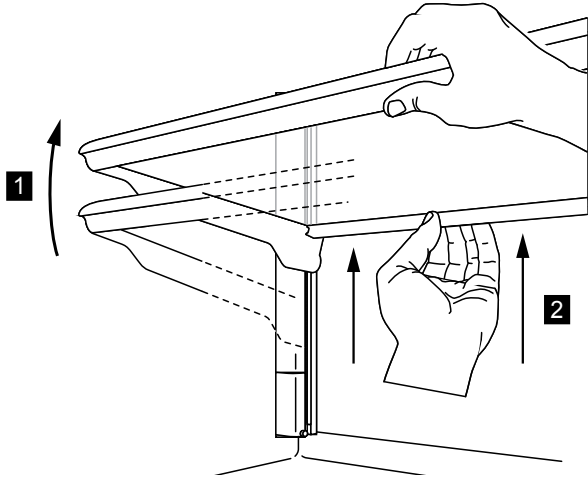

Upper Shelf Removal - Refrigerator Compartment

- To remove the lower refrigerator compartment shelf (just above the crisper drawer), lift it up, turn it at an angle **1** as shown, then pull it straight out **2**.

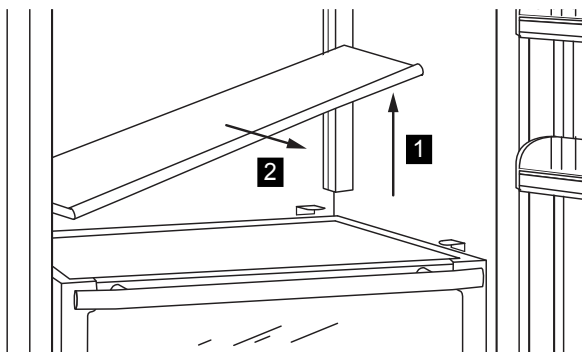

Lower Shelf Removal - Refrigerator Compartment

Crisper Drawer Removal

- The crisper drawers are attached to the drawer slides with two thumbscrews. To remove: unscrew the thumbscrews and lift up on the front of the drawer.

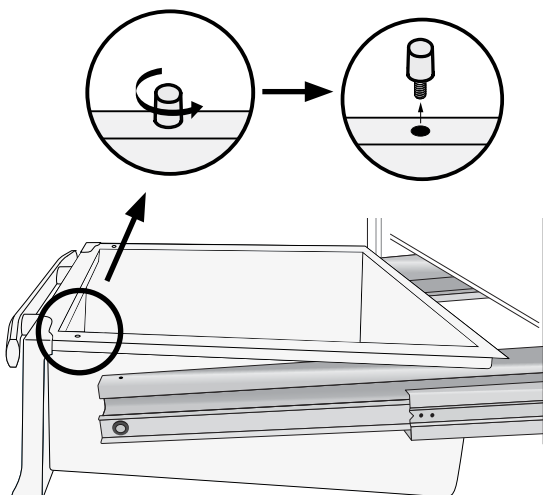

- When replacing each drawer, make sure the back edge of the drawer slides under the clips toward the rear of the slides.

FreshZone Freezer Drawer Removal

- The freezer drawer is attached to the drawer slides with two thumbscrews. Unscrew the thumbscrews and lift up on the front of the drawer to remove.

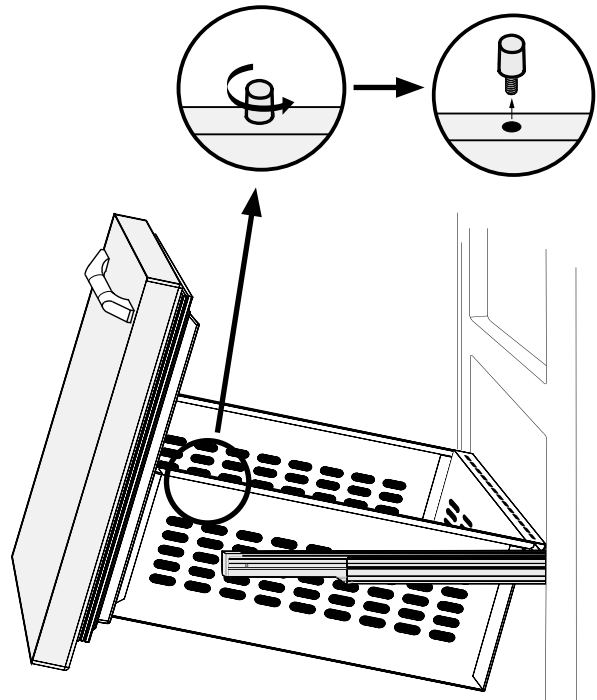

- When replacing the freezer drawer, make sure the back edge of the drawer slides under the clips toward the rear of the slides.

Ice Container Removal

- The ice container is designed to sit below the ice maker, in the freezer compartment, on the left side. Lift it up and out to remove.

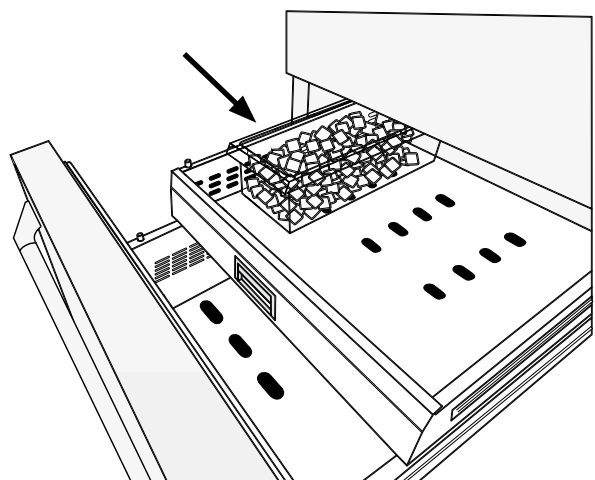

- After removal, reposition it correctly, on the left side of the compartment.

Care and Cleaning

Water Filter Replacement

- The water filter makes high-quality water for ice cubes.
- The filter has a capacity of up to 1060 gallons (4000 liters) of water for a maximum time of twelve months. The **Replace filter** message appears on the display when 30% of filter capacity is left. You can also use the water filter status feature (see page 13) to monitor filter usage
- Replace with Dacor filter # ABFF2 or 3M filter # AP2-C401-SG, available at www.everythingdacor.com or through your Dacor dealer.
- The filter is located inside the refrigerator compartment, above the top glass panel.

To replace the water filter:

1. Switch off the ice maker by taping the **ICE** key.
2. Perform a manual clean function (see page 14). At the end of the cleaning cycle, remove the water from the ice container and wipe it dry, then replace it.
3. Open the glass panel inside the top of the refrigerator compartment by pushing up and back on both sides of the plastic frame surrounding it, then lowering it down.
4. Carefully rotate the old filter cartridge counter-clockwise 1/4

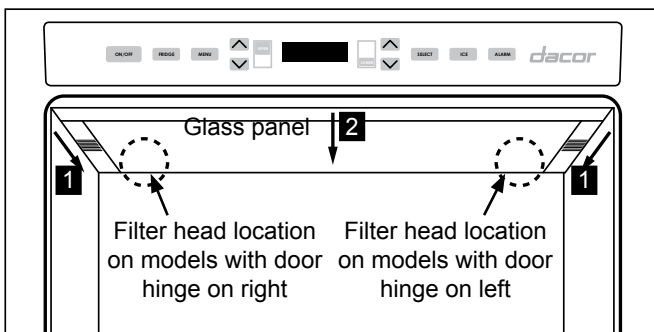

turn, until it detaches from the filter head. It is normal for a small quantity of water to come out.

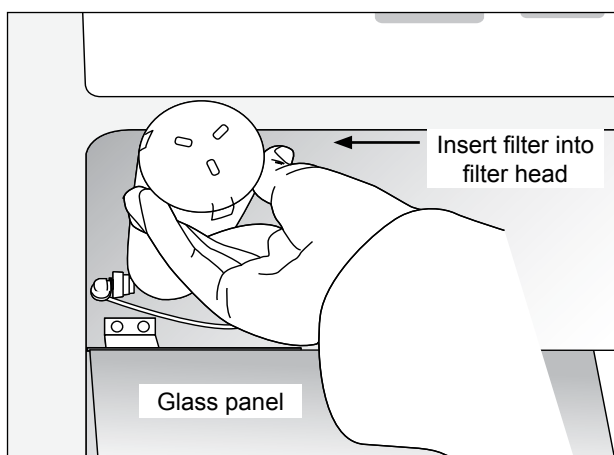

5. Remove the packaging on the new water filter cartridge and insert it into the filter head, located either to the right or left of the lighting system. Gently rotate the filter clockwise 1/4 turn, until it locks into place.
6. Reset the water filter status monitor by touching and holding both the **SELECT** and **ICE** keys until **Filter Reset OK** appears on the display.
7. Reinstall the glass panel by pushing it up into place, then pulling the plastic frame at the sides, toward you.

Lighting System

Your refrigerator is equipped with a long life LED lighting system. If the lights do not work, first check the "Lights do not work" portion of the **Before You Call for Service** section of this manual (page 25). If none of the suggestions listed remedy the problem, call a qualified service technician. Do not attempt to repair the lighting system yourself. It contains no user serviceable parts.

Before You Call for Service

Common Display Messages

Below is a list of the possible messages that may appear on the display in some cases and the suggested action.

Message	May Be Caused By	What to Do
Check condenser	Control panel displays this message every six months to remind the user to clean the condenser.	Clean the grill and condenser as instructed on page xx. Clear the message the SELECT key for five seconds. Reset condenser on will appear on display.
Check the Filter	Water filter is not installed.	Install water filter. See Using the Ice Maker for the First Time on page 6. If for some reason, you want to operate the ice maker without the filter installed, for example, you have a whole house water filter system, set the water filter to bypass. See page 6.
Door Fridge OPEN	Refrigerator door open for a long period of time.	Close door to prevent refrigerator compartment from becoming too warm.
Error Code or malfunction message	Functional problems	Call Dacor Customer Service to help you solve the problem or put you in contact with the nearest service agent. Some error messages can be cleared by touching the ALARM key for three seconds.
Fridge too cold	Refrigerator compartment too cold.	Wait for 12 hours; if malfunction persists call Dacor Customer Service for advice.
Fridge too warm	Refrigerator compartment too warm.	See Problem Solution Guide .
Initial Test	Appliance has just been turned on.	Normal operation. Message should clear by itself after a minute or two, as appliance starts up.
Power Failure!!	Prolonged interruption of electrical power	Appliance will automatically resume operation. Display will show warmest temperatures that have occurred inside unit. Minimize door openings to allow unit to cool down faster.
Replace filter	Message appears when only 30% of filter capacity is left	Replace filter soon. See page 23.
Standby	Appliance is turned off.	To turn on, see instructions on page 5.
Start Up Phase	Appliance has just been turned on.	Normal operation. Message comes on after initial test. Message should clear by itself after a few minutes, as appliance starts up.
FreshZone OPEN	FreshZone freezer drawer open for a long period of time.	Close drawer to prevent compartment from becoming too warm.
FreshZone too cold	FreshZone freezer compartment too cold.	Wait for 12 hours; if malfunction persists call Dacor Customer Service for advice.
FreshZone too warm	FreshZone freezer compartment too warm.	See Problem Solution Guide .
Unlock Key-pad	Control panel locked	To access control panel, unlock keypad. See page 5.

Before You Call for Service

Problem Solution Guide

Before you call for service, please review the **Problem Solution Guide** below and on the following pages.

Problem	May Be Caused By	What to Do
Nothing working - lights do not come on, cooling system not working.	Power is disconnected	Make sure power is on at the circuit breaker panel and that the power plug is properly connected to electrical outlet.
	Blown fuse or tripped circuit breaker	Replace fuse or reset circuit breaker.
	Power failure	Contact electric company.
Nothing working - lights not working, refrigerator and FreshZone freezer compartments not cooling, control panel display is working	Main power is off (stand by flashes periodically on display).	Open door and turn on main power using the ON/OFF key. See page 5.
Refrigerator and freezer compartments not cooling - lights work	Control panel malfunction	Look for error on control panel display. If one exists, call for service.
	Temperature not adjusted correctly.	Adjust temperature (see page 5). Allow at least 6 hours to reach the selected temperature
	Door/drawer left open or opened often, allowing cool air to escape.	Keep door/drawer closed and allow several hours for temperature to return to normal.
	Large amount of food recently added.	Keep door/drawer closed and allow several hours for temperature to return to normal.
FreshZone/Freezer compartment too warm, refrigerator compartment OK	FreshZone freezer compartment set to different temperature range than that desired.	The FreshZone freezer compartment can be set to act as a freezer compartment, refrigerator compartment or in between (Fresh). See pages 5 and 15 for more information.
	Temperature not adjusted correctly.	Adjust temperature (see page 5). Allow 12 hours to reach the selected temperature.
	Drawer left open for a long time or opened often, allowing cool air to escape.	Keep drawer closed and allow several hours for temperature to return to normal.
	Large amount of food recently added.	Keep drawer closed and allow several hours for temperature to return to normal.
No temperature displayed for refrigerator.	Refrigerator compartment turned off.	Check to see if FRIDGE key is lit. If not, refrigerator compartment is off. See Switching Refrigerator Off Only on page 5
Lights not working.	Appliance in Sabbath mode.	Check to see if appliance was accidentally placed into Sabbath mode. See page 18.
	Appliance in stand by mode.	Check to see if stand by is flashing on display. If so, see Switching On and Off on page 5.
	Appliance in initial test mode.	Right after the appliance is switched on, the lights take several seconds to come on while initial test is in process.
	Refrigerator compartment off.	Check to see if FRIDGE key is lit. If not, refrigerator compartment is off. See Switching Refrigerator Off Only on page 5

continued...

Before You Call for Service

Problem Solution Guide (cont.)

Problem	May Be Caused By	What to Do
System seems to run all the time	The appliance is powered by two independent compressors. One or both may be running at any given time.	Normal operation.
	Warm weather (warm room temperature)	It is normal for the system to run longer in warmer room temperatures.
	Appliance in Max Cool mode for either the refrigerator or FreshZone freezer compartment.	System runs longer due to additional cooling requirements of Max Cool feature.
	Door/drawer ajar or left open for a long time or opened often, allowing cool air to escape.	Keep door/drawer closed to reduce amount of time cooling system runs.
	Large amount of food recently added.	Allow several hours for system to return to normal operation.
Control panel beeps	Door left open too long, causes alarm to sound	Close door. Alarm may be silenced by tapping ALARM key. ALARM key will continue to flash.
	After a prolonged interruption of electrical power, alarm indicates temperature has risen above normal levels.	Close door and wait for unit to cool down. Alarm may be silenced by tapping ALARM key. ALARM key will continue to flash.
Condensation inside and outside of appliance.	Humid climate.	Formation of condensation normal in humid climates.
	Door/drawer open or ajar for a long time.	Door/drawer being ajar for a long time can cause condensation to form. Keep door/drawer closed.
Ice or frost build up inside the refrigerator or FreshZone (freezer) compartment.	Door/drawer open or ajar for a long time.	Door/drawer being ajar for a long time can cause ice to form inside. Keep door/drawer closed.
Door difficult to open.	Door blocked open by food	Move food away from door.
	Door gaskets sticky or dirty.	Clean door gaskets and contact surfaces with mild soap and warm water. Rinse and dry with soft cloth.
Door will not close completely	Drawer or shelf in the way.	Check to make sure drawers are closed and bins are in proper place.
Unusual noise	Grumbling: May be caused by refrigerating unit when running or fan in recirculating air system.	Normal operation.
	Bubbling, humming or gurgling noises: Refrigerant flowing through the tubes.	Normal operation.
	Clicking: Motor switching on or off. Solenoid valve on the water connection is opening/closing.	Normal operation.
	Rumbling: Ice cubes falling into ice cube container.	Normal operation.

Before You Call for Service

Problem	May Be Caused By	What to Do
Ice maker does not work or not producing enough ice.	Ice maker is off/disabled.	Ice maker can be turned off one of two ways, using the ice maker key and from the functions menu. First try activating the ice maker using the ICE key (see Ice Maker section on page 6). If ICE key does not light, try to enable ICE key from the functions menu as instructed on page 11.
	Water supply turned off or kink in water line.	Make sure water supply is on and flowing properly.
	FreshZone freezer compartment set to refrigerator or "fresh"	Ice maker will not work properly unless FreshZone (freezer) compartment is set to freezer mode. See FreshZone Setting on page 15.
	Ice maker has been turned off previously or new installation	12 to 24 hours are required after activation before ice production can begin. The ice maker produces 10 cubes per cycle, at approximately 10 cycles in 24 hours.
	Freezer drawer ajar.	Make sure freezer drawer is closed completely.
	Large amount of ice removed recently.	Allow time for production of additional ice.
	Water filter clogged or improperly installed.	Set filter to bypass (see page 13) and see if ice production increases. If it does, filter may not be installed properly or clogged (replace it).
Bad odor inside appliance.	Inside of compartment is dirty..	Clean inside of appliance according to the Care and Cleaning section.
	Food not properly covered.	Make sure that all food is properly covered.
	Old food inside appliance.	Discard food that is old/out of date.
Ice cubes have unusual odor or flavor	Impurities in water line	If using ice maker for first time, make sure you discard the first bin of ice to make sure that any impurities have been flushed from the water line. Follow this procedure also if refrigerator has not been used for several days.
	Ice cubes that have been in ice cube container for a long time may absorb odors	Empty ice cube container and clean. Allow it to refill.
	Ice cubes absorbing smell from food stored in freezer compartment.	Check the contents of the freezer for spoiled or out-of-date food. Odorous foods should be wrapped thoroughly or stored in airtight containers to prevent the build-up of odors.
	Water filter out of date.	Replace water filter.
	Water supply.	Contact a plumber or a water treatment expert to make sure problem is not due to water supply.
Ice cubes stick together	Ice cubes that have been in ice cube container for a long time may stick together	Empty ice cube tray and allow it to refill.
Ice cubes too small	Ice maker set to medium size cubes	Change ice maker setting to large size cubes. See page 12.

Warranty and Service

Getting Help

Before you request service:

- Review the **Before You Call for Service** section.
- Use the helpful tips found in the **Problem Solution Guide**.
- Become familiar with the **Warranty** terms and conditions of your product, below.
- If none of these tips or suggestions resolves your problem, call our Customer Service center at one of the numbers shown.

Dacor's Customer Service center is available
6:00 A.M. - 5:00 P.M. Pacific Time.

For warranty repairs or questions and for Dacor Distinctive Service (DDS) in the US and Canada:

Phone: (800) 793-0093, extension 2822

For non-warranty repairs or questions in the US and Canada:

Phone: (800) 793-0093, extension 2813

Contact us through our web site at:

www.dacor.com/contact-us

What Is Covered

CERTIFICATE OF WARRANTIES DACOR REFRIGERATORS

WITHIN THE FIFTY STATES OF THE U.S.A., THE DISTRICT OF COLUMBIA, AND CANADA:

FULL ONE YEAR WARRANTY

The warranty applies only to the Dacor appliance sold to the first use purchaser, starting from the date of original retail purchase or closing date for new construction, whichever period is longer. Warranty is valid on products purchased brand new from a Dacor Authorized Dealer or other seller authorized by Dacor.

If your Dacor product fails to function within one year of the original date of purchase due to a defect in material or workmanship, Dacor will remedy it without charge to you.

Except as noted above, consumable parts such as filters are not covered and are the responsibility of the purchaser.

LIMITATIONS OF COVERAGE

Service will be provided by a Dacor designated service company during regular business hours. Please note service providers are independent entities and are not agents of Dacor.

Dealer display and model home display products with a production date greater than 5 years, products sold "As Is," and products installed for non-residential use, which include but are not limited to religious organizations, fire stations, bed and breakfast, and spas carry a one year parts warranty only. All delivery, installation, labor costs and other service fees are the responsibility of the purchaser.

The owner must provide proof of purchase or closing statement for new construction upon request. All Dacor products must be accessible for service. All cosmetic damage (such as scratches on stainless steel, paint/porcelain blemishes, etc.) to the product or included accessories must be reported to Dacor within 60 days of the original purchase date to qualify for warranty coverage.

Warranty will be null and void on product that has altered, defaced, or missing serial numbers and tags.

OUTSIDE THE FIFTY STATES OF THE U.S.A., THE DISTRICT OF COLUMBIA, AND CANADA:

LIMITED FIRST YEAR WARRANTY

If your Dacor product fails to function within one year of the original date of purchase due to a defect in material or workmanship, Dacor will furnish a new part, F.O.B. factory to replace the defective part.

All delivery, installation, labor costs and other service fees are the responsibility of the purchaser.

What Is Not Covered

- Slight color variations may be noticed because of differences in painted parts, kitchen lighting, product placement and other factors; this warranty does not apply to color variation.
- Service calls to educate the customer on proper use and care of the product.
- Service fees for travel to islands and remote areas, which include but are not limited to, ferries, toll roads or other travel expenses.
- Consequential or incidental damage, including but not limited to food or medicine loss, time away from work or restaurant meals.
- Failure of the product when used for commercial, business, rental or any application other than for residential consumer use.
- Failure of the product caused by improper product installation.
- Replacement of house fuses, fuse boxes or resetting of circuit breakers.
- Damage to the product caused by accident, fire, flood, power interruption, power surges or other acts of God.
- Liability or responsibility for damage to surrounding property including cabinetry, floors, ceilings and other structures or objects around the product.
- Breakage, discoloration or damage to glass, metal surfaces, plastic components, trim, paint or other cosmetic finish caused by improper usage, care, abuse or neglect.

Out of Warranty

Should you experience a service issue beyond the standard warranty period, please contact us. Dacor reviews each issue and customer concern to provide the best possible solution based on the circumstances.

THE REMEDIES PROVIDED FOR IN THE ABOVE EXPRESS WARRANTIES ARE THE SOLE AND EXCLUSIVE REMEDIES. THEREFORE, NO OTHER EXPRESS WARRANTIES ARE MADE, AND OUTSIDE THE FIFTY STATES OF THE UNITED STATES, THE DISTRICT OF COLUMBIA AND CANADA, ALL IMPLIED WARRANTIES, INCLUDING BUT NOT LIMITED TO, ANY IMPLIED WARRANTY OF MERCHANTABILITY OR FITNESS FOR A PARTICULAR USE OR PURPOSE, ARE LIMITED IN DURATION TO ONE YEAR FROM THE DATE OF ORIGINAL PURCHASE. IN NO EVENT SHALL DACOR BE LIABLE FOR INCIDENTAL EXPENSE OR CONSEQUENTIAL DAMAGES. NO WARRANTIES, EXPRESS OR IMPLIED, ARE MADE TO ANY BUYER FOR RESALE.

Some states do not allow limitations on how long an implied warranty lasts, or do not allow the exclusion or limitation of inconsequential damages, so the above limitations or exclusions may not apply to you. This warranty gives you specific legal rights, and you may also have other rights that vary from state to state.

fold here



NO POSTAGE
NECESSARY
IF MAILED
IN THE
UNITED STATES

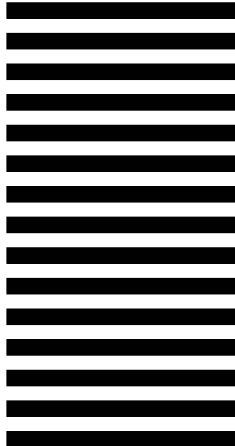

BUSINESS REPLY MAIL
FIRST-CLASS MAIL PERMIT NO 1600 CITY OF INDUSTRY CA

POSTAGE WILL BE PAID BY ADDRESSEE

**DACOR
ATTN WARRANTY PROCESSING DEPT
PO BOX 90070
CITY OF INDUSTRY CA 91715-9907**





Please visit www.dacor.com to activate your warranty online.

WARRANTY INFORMATION

**IMPORTANT:**

Your warranty will not be activated until you activate it online or return this form to Dacor. If you have purchased more than one Dacor product, please return all forms in one envelope or activate the warranty for each product online.

Please rest assured that under no conditions will Dacor sell your name or any of the information on this form for mailing list purposes. We are very grateful that you have chosen Dacor products for your home and do not consider the sale of such information to be a proper way of expressing our gratitude!

Owner's Name: _____
Last (Please Print or Type) First Middle

Street: _____

City: _____ State: _____ Zip: _____

Purchase Date: _____ Email: _____ Telephone: _____

Dealer: _____

City: _____ State: _____ Zip: _____

Your willingness to take a few seconds to fill in the section below will be sincerely appreciated. Thank you.

1. How were you **first** exposed to Dacor products? (Please check one only.)

- A. T.V. Cooking Show
- B. Magazine
- C. Appliance Dealer Showroom
- D. Kitchen Dealer Showroom
- E. Home Show
- F. Builder
- G. Architect/Designer
- H. Another Dacor Owner
- I. Model Home
- J. Other _____

2. Where did you buy your Dacor appliances?

- A. Appliance Dealer
- B. Kitchen Dealer
- C. Builder Supplier
- D. Builder
- E. Other _____

3. For what purpose was the product purchased?

- A. Replacement **only**
- B. Part of a Remodel
- C. New Home
- D. Other _____

4. What is your household income?

- A. Under \$75,000
- B. \$75,000 – \$100,000
- C. \$100,000 – \$150,000
- D. \$150,000 – \$200,000
- E. \$200,000 – \$250,000
- F. Over \$250,000

5. What other brands of appliances do you have in your kitchen?

- A. Cooktop _____
- B. Oven _____
- C. Dishwasher _____
- D. Refrigerator _____

6. Would you buy or recommend another Dacor product?

- Yes
- No

Comments: _____

Thank you very much for your assistance. The information you have provided will be extremely valuable in helping us plan for the future and giving you the support you deserve.

