

COMBO ICE MAKER/REFRIGERATOR

Model COMBO 29BTP

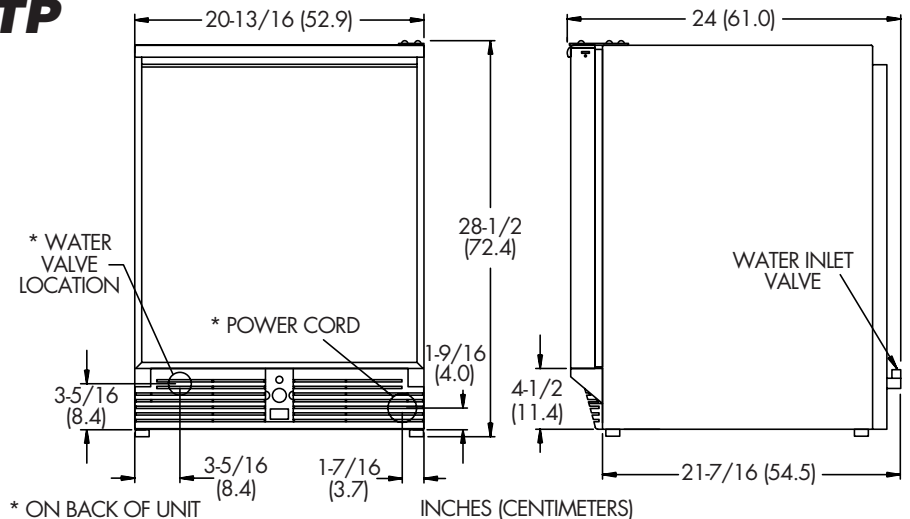
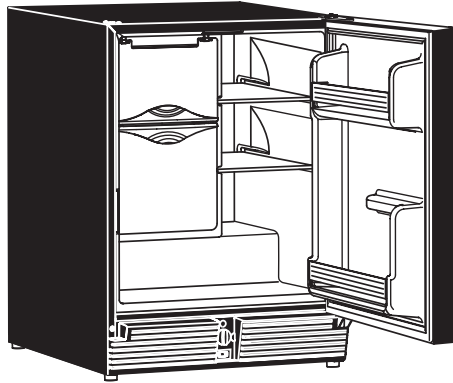

FEATURES

1. **Manual Defrost Ice Maker**
2. **Stainless hinges and mounting hardware**
3. **Travel pin – Factory installed**
4. **2.1 cubic feet of refrigeration**
5. **Front vented for built-in installation**
6. **No drain required for water**
7. **Conserves on water**
8. **Field reversible door with integrated door handle**
9. **Accepts custom door panel**
10. **In-door storage**
11. **Tempered glass shelves**

ADDITIONAL FEATURES:

- See through, removable ice bucket, stores 13 lbs. of ice
- Available in 110/115V – 60 cycle or 220/230 – 50/60 cycle
- Shipping weight: 97 lbs.
- Black vinyl clad steel cabinet and door panel
- Door panel size: H 21-13/32" x W 19-13/16"

BENEFITS

- Greater daily ice production capacity. Less affected by warmer ambients. Produces up to 18 lbs. of ice per day in a 70° ambient temperature.*
- Corrosive resistant.*
- Helps keep the door secure when en route. Pre-installed at factory.*
- Ice making and refrigeration in one compact unit.*
- No need for extra fans, air space, or special venting to the outside of the cabin. **Do not obstruct front grille.***
- Easy and inexpensive to install. Only needs 1/4" outside diameter water line connection.*
- Only 2-1/4 gallons of water needed to produce approximately 18 lbs. of ice.*
- Flexible installation capabilities to ensure easy access. With left hand door swing installation, allow for 145° door opening to ensure easy removal of ice bin.*
- Match surrounding cabinets.*
- 2 door shelves with clear bottle retainers for greater storage and easy access.*
- Generous amount of shelving space, easy to clean, helps contain spills.*