



Stainless



Black



White



Overlay

## 2175RC

**2000 SERIES**

### FEATURES

**PERFORMANCE**

- 5.2 cubic feet overall capacity maximizes storage
- Touch glass digital control featuring easy view command center manages key functions and provides user alerts such as an audible door open alarm
- Digital controlled single-zone convection cooling system provides a stable and consistent environment for optimum food and beverage storage
- Temperature setting from 34 to 45° F
- Sabbath / Blackout mode turns off all lighting, controls display and automatically resets after 36 hours
- Automatic defrost
- ENERGY STAR® / CEE Tier 3 rated
- UL residential and commercial listings

**INTERIOR / EXTERIOR**

- Lighted white interior optimizes easy viewing of contents
- Three tempered glass shelves with bullnose edge to maximize storage potential
- Convenient crisper drawer for proper storage and humidity control of perishable items
- Standard commercial stainless steel handle is interchangeable with professional handle option on stainless model
- Two adjustable in-door storage bins allow for flexible storage
- Full wrap stainless door on stainless model and unit must be ordered right or left hand hinged
- Black and white model doors are field reversible
- Vinyl clad textured cabinet is more resistant to scratching, peeling and flaking

**INTEGRATION**

- Unit can be built-in or freestanding providing a custom aesthetic
- Optional full 3/4" overlay panel on black and white models requires purchase of overlay kit PN: U-OL2115 and can be fully integrated into all styles of cabinetry
- Black and white models will accept a 1/4" insert panel to match with surrounding decor
- Allow a 2-1/2" clearance on hinged side for 90° door opening when installed adjacent to a wall (for stainless steel model)
- Allow 1/4" width overall for proper installation (see backside for details)
- No additional clearance around sides, top or rear of unit is needed for ventilation
- Durable, factory installed level legs provide a more precise undercounter fit
- Do not obstruct front grille air flow

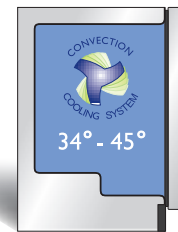

Single Zone  
Convection Cooling  
System featured in  
2175RC.



2175RC features flexible storage with in-door bins and crisper drawer.

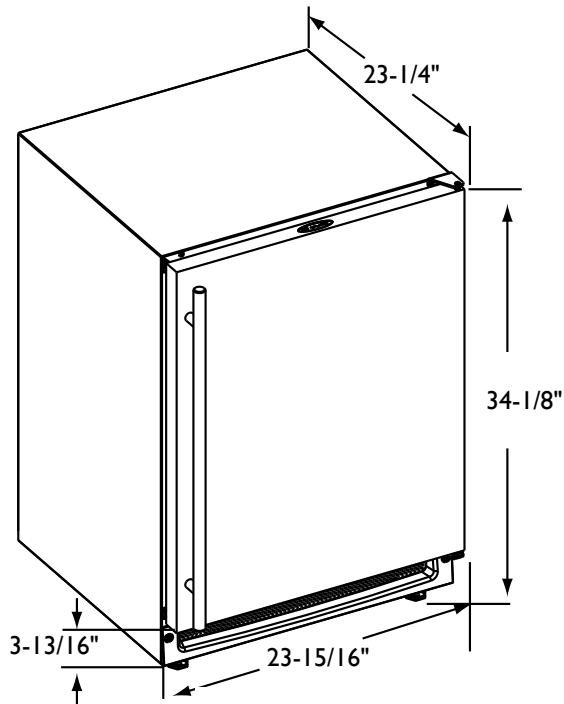

2175RC Stainless Model

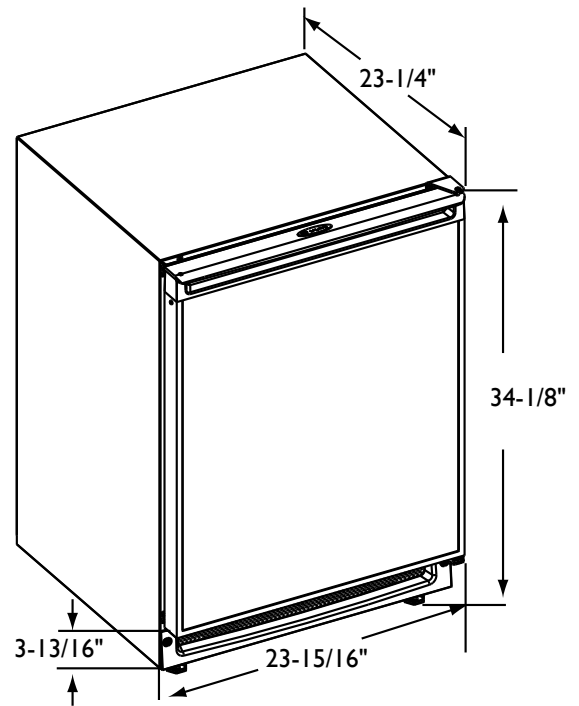
2175RCB Black Model and  
2115RCW White Model

## DIMENSIONS AND SPECIFICATIONS

## OVERALL DIMENSIONS

Height	34-1/8" (86.6)
Width	23-15/16" (60.8)
Depth	23-1/4" (59.0)
With stainless steel handle	25-1/8" (63.8)
<b>Shipping weight:</b>	
Black and white models	122 lbs (55 kg)
Stainless model	116 lbs (53 kg)
Running amps	2.4
Maximum start-up amps	9.8
Amps pertain to voltage rating	110/115 volt, 60 Hz
ENERGY STAR® and CEE Tier 3 Rated	

**Capacities:**

Defrost technology	Automatic
Refrigerator volume	5.2 Cu. Ft

Please visit [www.u-line.com](http://www.u-line.com) for installation guide.

All specifications are subject to change without notice.

## 2175RC

Stainless Right-hand	U-2175RCS-00
Stainless Left-hand	U-2175RCS-01
Black	U-2175RCB-00
White	U-2175RCW-00
Overlay	U-2175RCB-00 with Overlay kit U-OL2175B

