

## FFBF285SSX

75.25" x 27.63" x 24.75" (H x W x D)

ENERGY STAR qualified counter depth bottom freezer refrigerator with large capacity, deluxe interior, and stainless steel doors; replaces FFBF285SS

### Highlights:

Counter depth for an easy fit in space-challenged kitchens

Bottom freezer design offers easier accessibility

ENERGY STAR qualified performance ensures annual savings

Deluxe interior includes dual crispers, glass shelves, LED lighting, and scalloped steel wine rack



ENERGY STAR qualified	Rated by the DOE to perform with more efficiency than federal standards require, saving your unit energy and you on higher utility costs
Bottom freezer	Thoughtfully designed unit saves energy waste by putting the freezer under the refrigerator to keep commonly used contents at eye level
Counter depth fit	Perfectly sized for smaller space-challenged kitchens
Combination frost-free/auto defrost design	Frost-free freezer and auto defrost refrigerator section for maximum energy savings
Stainless steel doors	Professional look with lasting durability
Adjustable glass shelves	Rearrange your refrigerator space to accommodate all shapes and sizes or remove shelves for a simple clean-up
Door storage	Store tall bottles and condiments right on the door for convenient access
Wine shelf	Scalloped steel shelf is ideal for keeping bottles safely in place
Two clear crispers	Twin crisper drawers offer the ideal storage conditions for produce, helping you to keep your fruits and vegetables separated
Interior LED light	Energy efficient LED light automatically illuminates when the refrigerator door is opened

# FFBF285SSX Specifications:

Height	75.25"
Width	27.63"
Depth	24.75"
Capacity	13.81 cu.ft.
Ext Depth with Handle	26.75"
Interior Height 1	40.5"
Interior Width 1	24.25"
Interior Depth 1	18.25"
Interior Height 2	22.0"
Interior Width 2	21.5"
Interior Depth 2	15.25"
Shipping Weight	200.0 lbs.
Weight	180.0 lbs.
Voltage/Frequency	115 V AC/60 Hz
US Electrical Safety	ETL
Amps	1.5
Canadian Electrical Safety	ETL-C
Energy Usage/Year	412.0 kWh/year
Reversible	Yes
Door Swing	RHD
Crisper Quantity	2
Shelf Quantity	3
Adjustable Shelf	true
Shelf Type	Glass
Crisper Cover Type	Glass
Crisper Finish	Transparent
Full Door Shelf Quantity	4
Wine Bottle Holder	true
Drawers	true
Drawer Quantity	2
Defrost Type	Frost-Free/Automatic
Depth with door at 90°	52.38"
Light	true
Thermostat Type	Dial
Fan Type	Interior
Level Legs Quantity	2
Freon Oz	1.94
Low Side PSI	104.0
Refrigerant Type	R600a
High Side PSI	435.0
Parts/Labor Warranty	1 Year
Compressor Warranty	5 Years

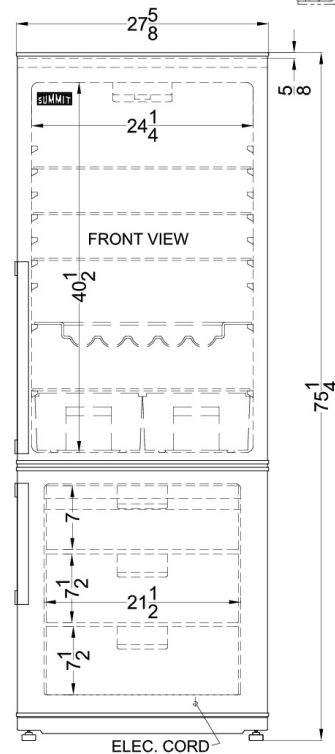
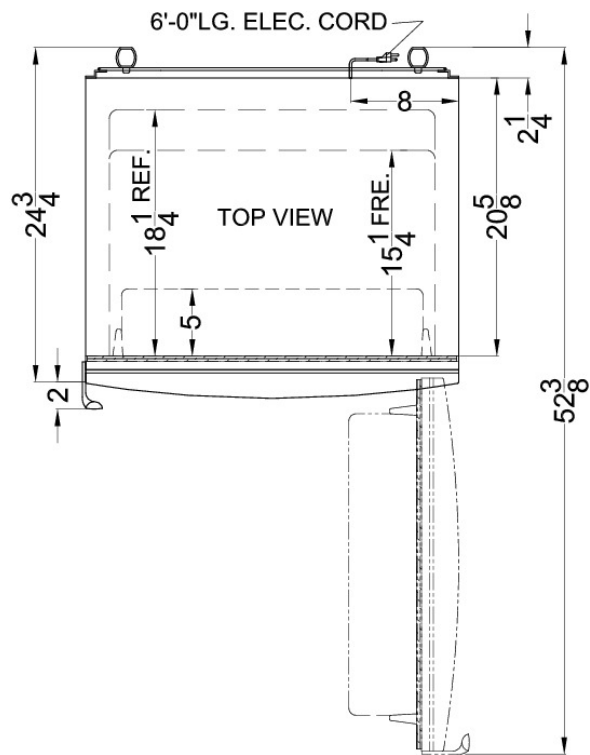

Summit Appliance Division, Felix Storch, Inc.  
 770 Garrison Ave • Bronx, NY 10474  
 Phone: 718-893-3900 • Fax: 718-842-3093  
 Email: info@summitappliance.com