

## Use & Care Manual



Built-in French Door  
Bottom-Freezer Refrigerator

## Congratulations

We hope you will enjoy and appreciate the care and attention we have put into every detail of your new, state-of-the-art refrigerator.

Your appliance is designed to offer years of reliable service. This Use and Care Guide will provide you with the information you need to become familiar with your refrigerator's care and operation.

Your complete satisfaction is our ultimate goal. If you have any questions or comments about this product, please contact the dealer from whom you purchased it, or contact our Consumer Support Center at 1-888-845-4641.

We appreciate your choice of our refrigerator and hope that you will again select our products for your other major appliance needs.

For more information about the complete and growing selection of products, contact your dealer or visit us online at [vikingrange.com](http://vikingrange.com) in the US or at [brigade.ca](http://brigade.ca) in Canada

# Table of Contents

## Getting Started

Refrigerator Safety	4
Important Safety Instructions	5
Proper Disposal (of old refrigerator)	6
Water Supply Requirements	8
Water System Preparation	9

## Product Controls

Using the Controls	10
Temperature Controls	12
Water Filter Indicator	13
Rest Mode	14
Alarm Functions	15

## Operation

Ice Maker	17
Water Filtration System	18
Water Filter Certifications	20
Refrigerator Features	22
Freezer Features	24

## Product Care

Cleaning	25
Changing the Light Bulb	26
Troubleshooting	28
Service Information	33
Warranty	34

# Refrigerator Safety

## Recognize Safety Symbols, Words, Labels

Warning and Important Safety Instructions appearing in this manual are not meant to cover all possible conditions and situations that may occur. Common sense, caution, and care must be exercised when installing, maintaining, or operating the appliance.

**ALWAYS** contact the manufacturer about problems or conditions you do not understand.

**Your safety is important to us.** This use and care manual contains safety symbols and statements. Always read and obey all safety messages.



This symbol alerts you to hazards such as fire, electrical shock or other injuries.

### **DANGER**

You can be killed or seriously injured if you don't immediately follow instructions.

### **WARNING**

You can be killed or seriously injured if you don't follow instructions.

### **CAUTION**

Hazards or unsafe practices which **COULD** result in minor personal injury.

All safety messages will identify the hazard, tell you how to reduce the chance of injury, and tell you what can happen if instructions are not followed.

### **WARNING**

#### State of California Proposition 65 Warning

- This product contains one or more chemicals known to the State of California to cause cancer.
- This product contains one or more chemicals known to the State of California to cause birth defects or other reproductive harm.

# Important Safety Instructions

## **WARNING**

To reduce the risk of fire, electric shock, or injury when using your refrigerator, follow these basic precautions:

- Plug into a grounded 3-prong outlet.
- **DO NOT** remove ground prong.
- **DO NOT** use an adapter.
- **DO NOT** use an extension cord.
- Disconnect power before servicing.
- Replace all parts and panels before operating.
- Remove doors from your old refrigerator.
- Use nonflammable cleaner.
- Keep flammable materials and vapors, such as gasoline, away from refrigerator.
- Use two or more people to move and install refrigerator.
- Disconnect power before installing ice maker (on ice maker kit ready models only).
- Use a sturdy glass when dispensing ice (on some models).

**SAVE THESE INSTRUCTIONS**

## **WARNING**

	<p><b>Electrical Shock Hazard</b></p> <p>Plug into a grounded 3 prong outlet. Do not remove ground prong. Do not use an adapter. Do not use an extension cord. Failure to follow these instructions can result in death, fire, or electrical shock.</p>
---	---

## **WARNING**

	<p><b>Explosion Hazard</b></p> <p>Keep flammable materials and vapors, such as gasoline, away from refrigerator. Failure to do so can result in death, explosion, or fire.</p>
---	--

## Proper Disposal (of old refrigerator)

### **⚠ WARNING**

#### **Suffocation Hazard**

Remove doors from your old refrigerator.  
Failure to do so can result in death or brain damage.

#### **IMPORTANT:**

Child entrapment and suffocation are not problems of the past. Junked or abandoned refrigerators are still dangerous—even if they will sit for “just a few days”. If you are getting rid of your old refrigerator, please follow these instructions to help avoid accidents.

#### **Before You Throw Away Your Old Refrigerator or Freezer:**

- Take off the doors.
- Leave the shelves in place so that children may not easily climb inside.

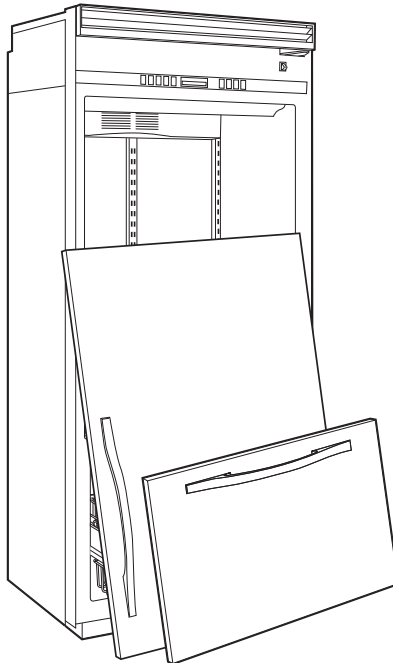

# Before Using your Refrigerator

## Remove the Packaging

- Remove tape and glue residue from surfaces before turning on the refrigerator. Rub a small amount of liquid dish soap over the adhesive with your fingers. Wipe with warm water and dry.
- Do not use sharp instruments, rubbing alcohol, flammable fluids, or abrasive cleaners to remove tape or glue. These products can damage the surface of your refrigerator. For more information, see "Refrigerator Safety."
- Dispose of/recycle all packaging materials.

## Clean Before Using

After you remove all of the packaging materials, clean the inside of your refrigerator before using it. See the cleaning instructions in "Refrigerator Care."

**⚠ CAUTION**

**Important information to know about glass shelves and covers:**

Do not clean glass shelves or covers with warm water when they are cold. Shelves and covers may break if exposed to sudden temperature changes or impact, such as bumping. Tempered glass is designed to shatter into many small, pebble-size pieces. This is normal. Glass shelves and covers are heavy. Use both hands when removing them to avoid dropping.

**⚠ WARNING**

**Broken Glass Hazard**



Do not hit refrigerator glass doors  
Protect glass surface and edges during installation or removal of doors.  
Failure to do so can result in serious eye injury or minor cuts.

# Water Supply Requirements

Read all directions before you begin.

## IMPORTANT:

- When your refrigerator was installed, the water connection from the water source should have been connected to your refrigerator. If your refrigerator is not connected to a water source, see "Connect to Water Line" in the Installation Instructions. If you have any questions about your water connection, see "Troubleshooting" or call a licensed, qualified plumber.
- If you turn the refrigerator on before the water line is connected, turn the ice maker OFF. See "Ice Maker and Storage Bin."
- All installations must meet local plumbing code requirements.

A cold water supply with water pressure between 30 and 120 psi (207 and 827 kPa) is required to operate the water dispenser and ice maker. If you have questions about your water pressure, see "Troubleshooting" or call a licensed, qualified plumber.

## Reverse Osmosis Water Supply

**IMPORTANT:** The pressure of the water supply coming out of a reverse osmosis system going to the water inlet valve of the refrigerator needs to be between 30 and 120 psi (207 and 827 kPa). If a reverse osmosis water filtration system is connected to your cold water supply, the water pressure to the reverse osmosis system needs to be a minimum of 40 psi (276 kPa).

If the water pressure to the reverse osmosis system is less than 40 psi (276 kPa):

- Check to see whether the sediment filter in the reverse osmosis system is blocked. Replace the filter if necessary.
- Allow the storage tank on the reverse osmosis system to refill after heavy usage.
- If your refrigerator has a water filter, it may further reduce the water pressure when used in conjunction with a reverse osmosis system. Remove the water filter. See "Water Filtration System."

If you have questions about your water pressure, call a licensed, qualified plumber.



## Water System Preparation

Please read before using the water system.

### IMPORTANT:

After connecting the refrigerator to a water source or replacing the water filter, fill and discard two full containers of ice to prepare the water filter for use, before using the ice.

### CAUTION

Do not use with water that is microbiologically unsafe or of unknown quality without adequate disinfection before or after the system.

1. Turn on the ice maker. Slide the ice maker On/Off control, located on the left-hand side of the ice bin, to the ON (up) position. Please refer to "Ice Maker and Storage Bin" for further instructions on the operation of your ice maker.

**NOTE:** Allow 24 hours to produce the first batch of ice.

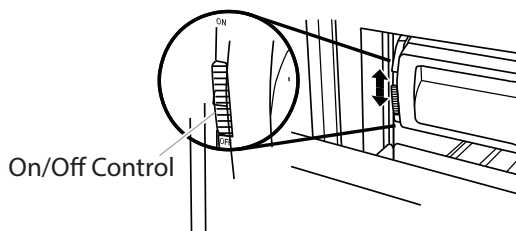

**NOTE:** If your model has a base grille water filter, make sure the water filter is properly installed so that the Eject button is out. See "Water Filtration System."

# Using the Controls

## Power ON/Off Switch

Before installing the top grille, turn the power switch to ON.

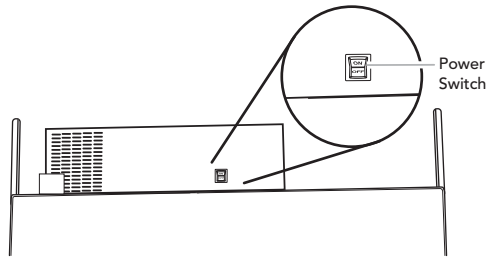

Product Controls

### To install the Top Grille:

1. Remove the grille from the packaging.

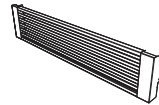

2. Locate pins above refrigerator..

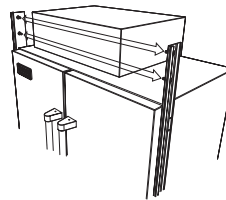

3. Place grille on top pins.

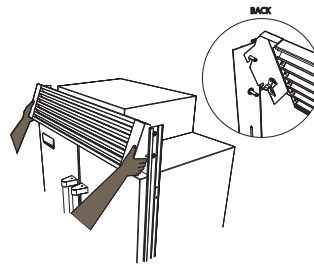

4. Rotate grille downward. Grille will snap in place once it is secure on the bottom pins.

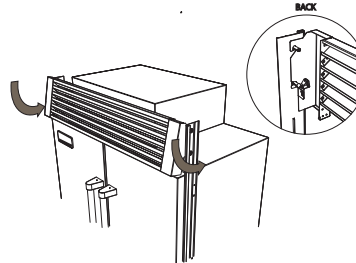

## Using the Controls

If you need to turn the power to your refrigerator Off after installation, you must remove the top grille assembly to access the power switch. Turn the power to the refrigerator Off when cleaning your refrigerator or changing light bulbs.

**To Remove Top Grille, reverse steps listed for installing the grille.**

1. Grasp the grille at the bottom. Pull up slightly to unsnap from bottom pins.
2. Lift upward to remove grille from top pins.

**IMPORTANT:** Be sure the power switch is set to the ON position after cleaning refrigerator or changing the light bulbs.

- The refrigerator control adjusts the refrigerator compartment temperature. The freezer control adjusts the freezer compartment temperature.
- Wait 24 hours after you turn on the refrigerator before you put food into it. If you add food before the refrigerator has cooled completely, your food may spoil.

**NOTE:** Adjusting the refrigerator and freezer controls to a lower (colder) setting will not cool the compartments any faster.

- If the temperature is too warm or too cold in the refrigerator or freezer, first check the air vents to be sure they are not blocked before adjusting the controls.
- The preset settings should be correct for normal household usage. The controls are set correctly when milk or juice is as cold as you like and when ice cream is firm.
- The actual temperature may differ from the display when a door is open for an extended period of time.

**NOTE:** The factory recommended set points are 0°F (-18°C) for the freezer and 37°F (3°C) for the refrigerator.

# Using the Controls

## Turning Refrigerator On and Viewing Set Points

- Press the ON/OFF touch pad.



### NOTE:

- After the refrigerator is turned on, the Over Temperature audio alarm and indicator light may activate every 1½ hours until the refrigerator and freezer temperatures are below 48°F (9°C) and 15°F (-9°C), respectively, or until the alarm is turned off. To turn off the audio alarm and indicator light, see "Master Alarm Reset."
- The ON/OFF touch pad on the control panel shuts down refrigerator functions such as cooling, lighting, fans and compressors. To turn the power off completely, use the power ON/OFF switch located behind the top grille. See "Power On/ Off Switch."

## Viewing the Celsius Temperatures

- Press °C touch pad. To redisplay degrees Fahrenheit, press °C again.



**NOTE:** If the freezer temperature is below zero, the negative sign next to the freezer display will light up. This is normal.

## Adjusting Controls

**NOTE:** Wait at least 24 hours between adjustments. Recheck the temperatures before other adjustments are made.

### To Adjust Set Point Temperatures:

- Press the refrigerator or freezer PLUS (+) or MINUS (-) touch pad until the desired temperature is reached.

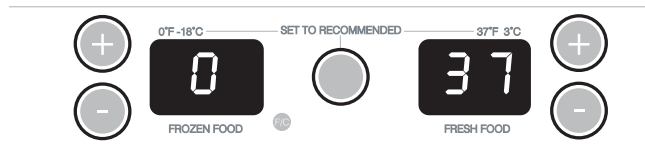

- Press the Set To Recommended touch pad to reset the set points to the factory recommended temperatures.  
**NOTE:** The set point range for the freezer is -5°F to 5°F (-21°C to -15°C). The set point range for the refrigerator is 33°F to 45°F (0°C to 7°C).

## Using the Controls

CONDITION/REASON:	TEMPERATURE ADJUSTMENT:
REFRIGERATOR too cold Not set correctly for conditions	REFRIGERATOR Control 1° higher
REFRIGERATOR too warm High use or room very warm	REFRIGERATOR Control 1° lower
FREEZER too cold Not set correctly for conditions	FREEZER Control 1° higher
FREEZER too warm/too little ice High use or heavy ice use	FREEZER Control 1° lower

### Water Filter Indicator and Reset

See "Water Filter Indicator" in the "Water Filtration System" section.

### Max Cold

The Max Cold feature assists with periods of heavy ice usage, full grocery loads, or temporarily warm room temperatures.

- Press MAX COLD to turn on the Max Cold feature. The Max Cold indicator light will remain on for 24 hours unless manually turned off.



**NOTE:** The temperature display will remain at 34°F (1°C) and -5°F (-21°C) for the refrigerator and freezer compartments, respectively, while the Max Cold feature is enabled. After 24 hours, the refrigerator returns to the previous temperature set points.

# Using the Controls

Operation

## Rest Mode

The Rest Mode feature is designed for the traveler or for those whose religious observances require turning off the lights and ice maker. By selecting this feature, the temperature set points and Deli Pan settings remain unchanged, the ice maker will be disabled and the interior lights will turn off. For most efficient refrigerator operation, it is recommended to exit the Rest Mode when it is no longer required.

- Press REST MODE to turn on the Rest Mode feature. This feature will remain on until Rest Mode is pressed again.



**NOTE:** If the Max Cold feature has been selected prior to turning on the Rest Mode feature, then the set points will remain at 34°F (1°C) and -5°F (-21°C) for the refrigerator and freezer compartments, respectively, until the Max Cold feature times out. The refrigerator will then return to the previous temperature set points chosen prior to the selection of the Max Cold feature, but the lights and ice maker will remain off until the Rest Mode is pressed again.

## Energy Saver™ Feature

The Energy Saver feature controls the heaters located inside the hinged seal between the refrigerator doors. The heaters help keep external moisture from forming on the hinged seal.

- Press ENERGY SAVER control to turn on this feature for low humidity conditions. The ring around the control will be lit when Energy Saver is on. If moisture begins to collect on the hinged seal between the doors, press ENERGY SAVER control again to turn off this feature.



## Sales Demonstration Mode

This mode provides a sequential display of the temperature displays and feature LEDs.

To enter the Demonstration Mode, press and hold the Max Cool and Power On/Off keys for 2 seconds. If the refrigerator or freezer door is open for 10 minutes, the interior lights will turn off.



# Using the Controls

## Alarm Functions

### Master Alarm Reset

Pressing Alarm Reset once will turn off the audio alarm and indicator light. The audio alarm will not sound again for the current condition that caused the alarm until a new condition occurs or until a Master Alarm Reset is performed.

A Master Alarm Reset can be performed by pressing ON/ OFF twice or by turning the power to the refrigerator off and on again. See "Power On/Off Switch." After performing a Master Alarm Reset, the indicator light will reactivate if the condition that caused the alarm is still present. See "Over Temperature," "Call Service," or "Door Open."



### Door Open

The Door Open indicator light will flash, an alarm will sound and the interior lights will turn off when a door has been open for longer than 10 minutes. When the door is closed, the audio alarm will reset and turn off, but the Door Open indicator light will continue to flash until the temperature is equal to or below 45°F (7°C) and 15°F (-9°C) for the refrigerator and freezer compartments, respectively.

NOTE: To deactivate the audio alarm and indicator light, see "Master Alarm Reset."

NOTE: The audio alarm will be disabled for subsequent occurrences of over temperature alarm condition. To enable the audio alarm, see "Master Alarm Reset."

## Using the Controls

### Over Temperature

**IMPORTANT:** If the Over Temperature Alarm activates, your food may spoil. See the "Power Interruptions." Minimize door openings until temperatures return to normal.

The Over Temperature feature is designed to let you know when either the refrigerator temperature rises above 48°F (9°C) or the freezer temperature rises above 15°F (-9°C) for longer than 1½ hours. The audio alarm will shut off automatically when the temperature returns to normal, but the indicator light will continue to flash until the Alarm is pressed to let you know that an over temperature condition has occurred.

If the over temperature condition is still present when an Over Temperature Reset is performed, the indicator light will continue to reactivate every 1½ hours until refrigerator and freezer temperatures are below 48°F (9°C) and 15°F (-9°C), respectively.

### Call Service

If the Call Service indicator light is flashing, call for service. See the "Assistance or Service" section for information on calling for service.

**NOTE:** The audio alarm will be disabled for subsequent occurrences of the call service alarm condition. To enable the audio alarm, see "Master Alarm Reset"



# Ice Maker

**IMPORTANT:** After connecting the refrigerator to a water source or replacing the water filter, fill and discard two full containers of ice to prepare the water filter for use, before using the ice.

## Turn the Ice Maker On/Off

The ice maker On/Off control is located on the left-hand side of the ice bin.

1. To turn on the ice maker, slide the ice maker On/Off control to the ON (up) position.

**NOTE:** Your ice maker has an automatic shutoff. As ice is made, the ice cubes will fill the ice storage bin. The ice maker sensors will automatically stop ice production, but the ice maker control will remain in the ON (up) position.

2. To manually turn off the ice maker, slide the ice maker On/Off control to the OFF (down) position as shown.

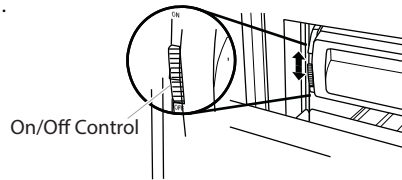

## Ice Storage Bin Care

**NOTE:** It is normal for ice to stick together in the ice bin. It is recommended that the ice bin be emptied and cleaned as needed.

To clean the ice storage bin:

1. Slide the ice bin out of the freezer and lift up and out.
2. Empty the ice bin. Use warm water to melt the ice if necessary.  
**NOTE:** Do not use anything sharp to break up the ice in the bin. This can cause damage to the ice container and the dispenser mechanism.
3. Wash ice bin with warm water and a mild detergent, rinse well and dry thoroughly. Do not use harsh or abrasive cleaners or solvents.

### REMEMBER:

- Allow 24 hours to produce the first batch of ice.
- It may take 3 to 4 days for the ice bin to completely fill, if no ice is used.
- The quality of your ice will be only as good as the quality of the water supplied to your ice maker.
- Avoid connecting the ice maker to a softened water supply. Water softener chemicals (such as salt) can damage parts of the ice maker and lead to poor quality ice. If a softened water supply cannot be avoided, make sure the water softener is operating properly and is well maintained.
- It is normal for the ice cubes to be attached at the corners. They will break apart easily.
- Do not store anything inside the ice bin.

# Water Filtration System

## ⚠ CAUTION

Do not use with water that is microbiologically unsafe or of unknown quality without adequate disinfection before or after the system.

### Water Filter Indicator

The water filter indicator, located on the control panel, will help you know when to change the water filter.

A new water filter should display a reading of 99%. The reading in the display will decrease as the filter life is used. A replacement water filter should be ordered when "Order Filter" is displayed. It is recommended that you replace the filter when "Change Filter" is displayed or when water flow to your water dispenser and/or ice maker decreases noticeably. See "Changing the Water Filter" later in this section.

After changing the water filter, press and hold RESET for 2 seconds until the status display changes to 99%.

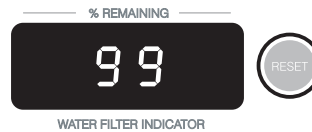

### Changing the Water Filter

The water filter is located in the base grille below the freezer compartment door. It is not necessary to remove the base grille to remove the filter.

1. Remove the filter by pressing the eject button and pulling straight out on the filter cap.

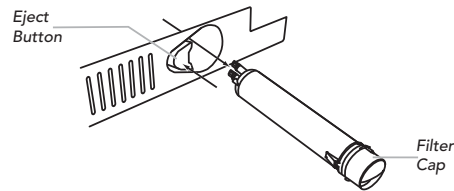

#### NOTES:

- Avoid twisting the cap when removing the filter because this could cause the cap to come off. If this occurs, replace the cap and pull the filter straight out.
  - There will be water in the filter. Some spilling may occur.
2. Remove the cap by turning it counterclockwise until it stops.  
**IMPORTANT:** Do not discard the cap. It is part of your refrigerator. Keep the cap to use with the replacement filter.

# Water Filtration System

3. Align the ridge on the cap with the arrow on the new filter and turn the cap until it snaps into place.

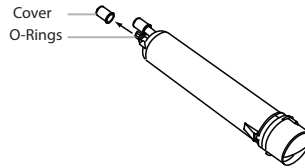

4. Remove the covers from the O-rings. Be sure the O-rings are still in place after the covers are removed.
5. Place the cap (removed in Step 2) on the new filter. Align the ridge on the cap with the arrow on the filter. Turn the cap clockwise until it snaps into place.
6. Push the new filter into the opening in the base grille. As the filter is inserted, the eject button will depress. The eject button will pop back out when the filter is fully engaged.
7. Pull gently on the cap to check that the filter is securely in place.
8. Flush the water system. Depending on your model, see "Water and Ice Dispensers" or "Ice Maker and Storage Bin."

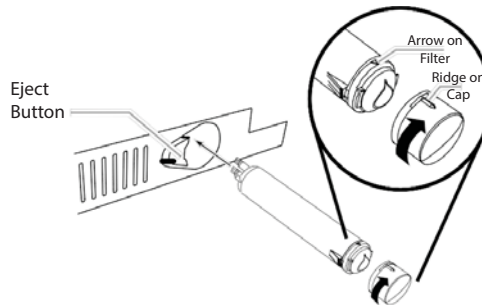

## Using the Ice Maker Without a Water Filter

You can operate the ice maker without a water filter. Your ice will not be filtered.

1. Remove the filter by pressing the eject button and pulling on the cap. See "Changing the Water Filter" earlier in this section.
2. Remove the cap by turning it counterclockwise until it stops.  
**IMPORTANT:** Do not discard the cap. It is part of your refrigerator. Keep the cap to use with the replacement filter.
3. With the cap in a horizontal position, insert the cap into the base grille until it stops.
4. Turn the cap counterclockwise until the cap slips into the attachment slot. Then, turn the cap clockwise until it is in a horizontal position. **NOTE:** The cap will not be even with the base grille.

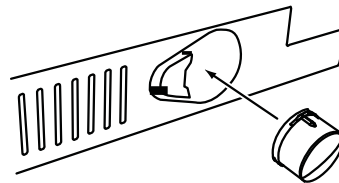

Operation

# WATER FILTER CERTIFICATIONS

# Water Filtration System

State of California  
Department of Health Services  
Water Treatment Device  
Certificate Number

05 - 1703

Date Issued: April 6, 2005  
Date Revised: September 7, 2005

Trademark/Model Designation	Replacement Elements
Whirlpool Deluxe T2WG2	T2RFWG2
Whirlpool Deluxe T2WG2L	T2RFWG2L
KitchenAid Deluxe T2WG2	T2RFWG2
KitchenAid Deluxe T2WG2L	T2RFWG2L

Manufacturer: Whirlpool Corporation

The water treatment device(s) listed on this certificate have met the testing requirements pursuant to Section 116830 of the Health and Safety Code for the following health related contaminants:

**Microbiological Contaminants and Turbidity**

Note:

**Organic Contaminants**  
Carbon  
o-Dichlorobenzene  
Toxaphene

**Inorganic/Radiological Contaminants**

Lead  
Mercury

**Microbiological Contaminants and Turbidity**

Note:

**Organic Contaminants**  
Benzene  
Carbon  
o-Dichlorobenzene  
Toxaphene

**Inorganic/Radiological Contaminants**

Lead  
Mercury

The water treatment device(s) listed on this certificate have met the testing requirements pursuant to Section 116830 of the Health and Safety Code for the following health related contaminants:

**Microbiological Contaminants and Turbidity**

Note:

**Organic Contaminants**  
Benzene  
Carbon  
o-Dichlorobenzene  
Toxaphene

**Inorganic/Radiological Contaminants**

Lead  
Mercury

Rated Service Capacity: 200 gals

Rated Service Flow: 0.85 gpm

**Conditions of Certification:**  
Do not use with water that is microbiologically unsafe or of unknown quality, without adequate disinfection before or after the system.

Rated Service Capacity: 200 gals

Rated Service Flow: 0.5 gpm

**Conditions of Certification:**  
Do not use with water that is microbiologically unsafe or of unknown quality, without adequate disinfection before or after the system.

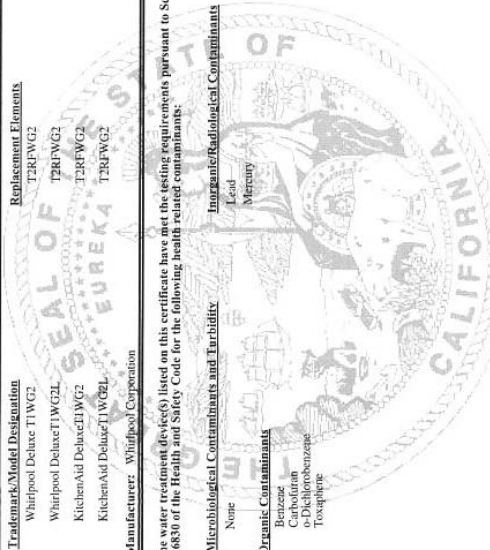

# Performance Data Sheet

## Base Grille Water Filtration System Model 11WG2L/2RPFWG2 Capacity 200 Gallons (757 Liters) Model 11WG2L/2RPFWG2 Capacity 200 Gallons (757 Liters)



System tested and certified by NSF International against NSF/ANSI Standard 42 for the reduction of Chlorine Taste and Odor, Particulate Class 1\*, and against NSF/ANSI Standard 53 for the reduction of Mercury, Benzene, Trihalomethanes, and Carbofuran.

This system has been tested according to NSF/ANSI 42/53 for the reduction of the substances listed below. The concentration of the water entering the system, as specified in NSF/ANSI 42/53, was reduced to a concentration less than or equal to the permeable limit for water leaving the system.

Substance Reduction Requirements	NSF Reduction Requirements	Influent Challenge Concentration		Effluent		Maximum % Reduction	Average % Reduction
		Influent Concentration	Permeable Class 1*	Maximum	Average		
Chlorine Residual	85% reduction	13333333 mg/L	At least 10,000 particulate/ml	6000 mg/L	2225 mg/L	99.51	99.83
Particulate Class 1*	85% reduction	13333333 mg/L	At least 10,000 particulate/ml	6000 mg/L	2225 mg/L	99.51	99.83
Lead @ pH 6.5**	0.010 mg/L	0.1535 mg/L	0.13 mg/L ± 10%	0.0005 mg/L	0.0005 mg/L	99.67	99.67
Cadmium	0.010 mg/L	0.1535 mg/L	0.13 mg/L ± 10%	0.0005 mg/L	0.0005 mg/L	99.67	99.67
Lead @ pH 8.5**	0.010 mg/L	0.1535 mg/L	0.13 mg/L ± 10%	0.0005 mg/L	0.0005 mg/L	99.67	99.67
Mercury @ pH 8.5	0.005 mg/L	0.0059 mg/L	0.005 mg/L ± 10%	0.0005 mg/L	0.0005 mg/L	91.52	96.54
Benzene	0.005 mg/L	0.0154 mg/L	0.015 mg/L ± 10%	0.0005 mg/L	0.0005 mg/L	98.22	96.34
Trihalomethanes	0.1 mg/L	1.1791 mg/L	1.18 mg/L ± 10%	0.0250 mg/L	0.0250 mg/L	98.38	99.83
Carbofuran	0.04 mg/L	0.0819 mg/L	0.08 mg/L ± 10%	0.0005 mg/L	0.0013 mg/L	91.53	74.00

Test Parameters: pH = 7.5 ± 0.5 unless otherwise noted. Flow = 0.5 gpm (0.9 L/min). Pressure = 60 psig (4.137 MPa). Temp. = 68°F to 71.6°F (20°C to 22°C). Rated service capacity = 200 gallons (757 liters).

- These contaminants are not necessarily in your water supply, conditions, actual performance may vary.
- Do not use with water that is microbiologically unstable or of uncertain quality without adequate disinfection before or after the system.
- Refer to the "Warranty" section for the Manufacturer's name, address and telephone number.
- Refer to the "Warranty" section for the Manufacturer's limited warranty.

Application Guidelines/Water Supply Parameters	
Water Supply	City or Well
Water Pressure	30 - 120 psi (207 - 827 kPa)
Water Temperature	35° - 100°F (0° - 37.8°C)
Service Flow Rate	0.5 gpm (0.2 L/min) @ 60 psi



## Base Grille Water Filtration System Model 12WG2L/2RPFWG2 Capacity 200 Gallons (757 Liters) Model 12WG2L/2RPFWG2 Capacity 200 Gallons (757 Liters)



System tested and certified by NSF International against NSF/ANSI Standard 42 for the reduction of Chlorine Taste and Odor, Particulate Class 1\*, and against NSF/ANSI Standard 53 for the reduction of Mercury, Benzene, Trihalomethanes, and Carbofuran.

This system has been tested according to NSF/ANSI Standards 42 and 53 for the reduction of the substances listed below. The concentration of the water entering the system, as specified in NSF/ANSI Standards 42 and 53, was reduced to a concentration less than or equal to the permeable limit for water leaving the system.

Substance Reduction Requirements	NSF Reduction Requirements	Influent Challenge Concentration		Effluent		Maximum % Reduction	Average % Reduction
		Influent Concentration	Permeable Class 1*	Maximum	Average		
Chlorine Residual	85% reduction	13333333 mg/L	At least 10,000 particulate/ml	6000 mg/L	2225 mg/L	99.51	99.83
Particulate Class 1*	85% reduction	13333333 mg/L	At least 10,000 particulate/ml	6000 mg/L	2225 mg/L	99.51	99.83
Lead @ pH 6.5**	0.010 mg/L	0.1535 mg/L	0.13 mg/L ± 10%	0.0005 mg/L	0.0005 mg/L	99.67	99.67
Cadmium	0.010 mg/L	0.1535 mg/L	0.13 mg/L ± 10%	0.0005 mg/L	0.0005 mg/L	99.67	99.67
Lead @ pH 8.5**	0.010 mg/L	0.1535 mg/L	0.13 mg/L ± 10%	0.0005 mg/L	0.0005 mg/L	99.67	99.67
Mercury @ pH 8.5	0.005 mg/L	0.0059 mg/L	0.005 mg/L ± 10%	0.0005 mg/L	0.0005 mg/L	91.52	96.54
Benzene	0.005 mg/L	0.0154 mg/L	0.015 mg/L ± 10%	0.0005 mg/L	0.0005 mg/L	98.22	96.34
Trihalomethanes	0.1 mg/L	1.1791 mg/L	1.18 mg/L ± 10%	0.0250 mg/L	0.0250 mg/L	98.38	99.83
Carbofuran	0.04 mg/L	0.0819 mg/L	0.08 mg/L ± 10%	0.0005 mg/L	0.0013 mg/L	91.53	74.00

Test Parameters: pH = 7.5 ± 0.5 unless otherwise noted. Flow = 0.65 gpm (0.2 L/min). Pressure = 60 psig (4.137 MPa). Temp. = 68°F to 71.6°F (20°C to 22°C). Rated service capacity = 200 gallons (757 liters).

- These contaminants are not necessarily in your water supply, conditions, actual performance may vary.
- Do not use with water that is microbiologically unstable or of uncertain quality without adequate disinfection before or after the system.
- Refer to the "Warranty" section for the Manufacturer's name, address and telephone number.
- Refer to the "Warranty" section for the Manufacturer's limited warranty.

Application Guidelines/Water Supply Parameters	
Water Supply	City or Well
Water Pressure	30 - 120 psi (207 - 827 kPa)
Water Temperature	35° - 100°F (0° - 37.8°C)
Service Flow Rate	0.65 gpm (0.2 L/min) @ 60 psi



\*Tested at particle size: 1 um to <math>5 \mu\text{m}</math>  
 \*\*Test requirements is at least 100,000 particulate/ml of AC Fine Test Dust  
 \*\*\*Compliant for Lead reduction requirements under NSF/ANSI Standard 53 as tested by Peace Analytical Services, Inc.  
 © NSF is a registered trademark of NSF International.

\*Tested at particle size: 1 um to <math>5 \mu\text{m}</math>  
 \*\*Test requirements is at least 100,000 particulate/ml of AC Fine Test Dust  
 \*\*\*Compliant for Lead reduction requirements under NSF/ANSI Standard 53 as tested by Peace Analytical Services, Inc.  
 © NSF is a registered trademark of NSF International.



# Refrigerator Features

## Shelves and Shelf Frames

### ⚠ CAUTION

#### Glass Shelves and Covers

Do not clean glass shelves or covers with warm water when they are cold. Shelves and covers may break if nicked, scratched, or exposed to sudden temperature changes or impact, such as bumping. Tempered glass is designed to shatter into many small, pebble-size pieces. This is normal. Glass shelves and covers are heavy. Use both hands when removing them to avoid dropping.

#### Spillproof Plus Shelves with Nano Technology

Some refrigerator models include Spillproof Plus shelves. These spillproof shelves contain liquids with no raised edges in order to provide extra shelf capacity.

#### Standard Spillproof Shelves

Standard spillproof shelves are constructed of polypropylene molded around the glass and metal rail. This design means that the shelves are completely enclosed and liquids can't seep under the glass. This localizes spills and makes clean-up easier.

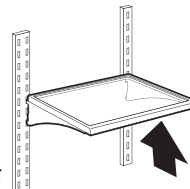

**NOTE:** Foods and beverages placed on the uppermost shelf under the air vent may freeze.

Operation

#### Shelf Adjustment

You can adjust the shelves to match the way you use your refrigerator. To remove the shelves, tilt the shelf up at the front releasing the hooks from the shelf support, then pull the shelf straight out.

To replace shelves, guide the rear hooks of the shelf into the slots in the shelf supports. Then, tilt the shelf up at the front until the hooks drop into the slots, and lower the front of shelf to level position.

### ⚠ CAUTION

To avoid personal injury and property damage, confirm shelf is secure before placing items on shelf.

# Refrigerator Features

## Deli / Crisper Pans and Deli Control Panel

The control panel located above each deli pan has the following three temperature settings: Deli, Produce, Meats (Cold to Coldest) and the Quick Chill setting. Select the appropriate setting for the food being stored

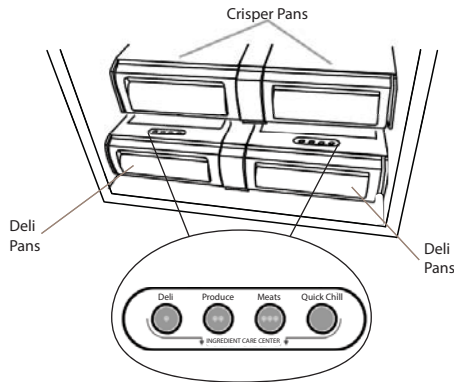

## Meat Storage Guide

Store most meat in original wrapping as long as it is airtight and moisture-proof. Rewrap if necessary. See the following chart for storage times. When storing meat longer than the times given, freeze the meat.

Fresh fish or shellfish . . . . .	use same day as purchased
Chicken, ground beef, variety meat (liver, etc.) . . . . .	1-2 days
Cold cuts, steaks/roasts . . . . .	3-5 days
Cured meats. . . . .	7-10 days

Leftovers - Cover leftovers with plastic wrap, aluminum foil, or plastic containers with tight lids.

## Quick Chill Setting

Each deli pan has a Quick Chill setting. Selecting Quick Chill lowers the temperature of the deli pan for a 1-hour period.

**NOTE:** The deli pan temperature will be lower than the freezing point for liquids. Remove items that may freeze, before setting the deli pan to Quick Chill

Operation

# Refrigerator Features

## Crisper Pan

Above each deli pan is a crisper pan (the larger of the pans) which is for your larger produce items.

### Remove and Replace the Deli/Crisper Pans

1. Slide the deli/crisper pan straight out to the stop. Lift the front of the pan with one hand while supporting the bottom with the other hand. Slide the pan out the rest of the way.
2. To replace the deli/crisper pan, pull out the pan slides until they are fully extended and set the pan on the slides. Push the pan in toward the back until it is in closed position.
3. Reopen the deli/crisper pan to make sure it has been replaced properly.



# Refrigerator Features

## Utility Compartment

The utility compartment can be placed in any position on the refrigerator door.

### To Remove and Replace the Utility Bin:

1. Remove utility compartment by grasping both ends and lifting compartment up and out.
2. Replace the bin by sliding it in above the desired support and pushing it down until it stops.

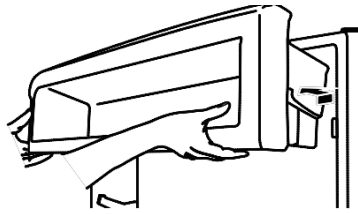

## Door Bins

Large door bins hold gallon containers and the smaller door bins hold 2-liter bottles. The door bins are adjustable and removable for easy cleaning and adjusting.

### Gallon Door Bin

#### To Install Gallon Door Bin:

**NOTE:** The gallon door bin can only be placed on the lower support.

1. Position gallon door bin above lowest door adjustment slot.
2. Push down to secure bin.
3. Adjust other bins, as necessary to allow for milk or beverage container height.

### Small Door Bins

#### To Remove and Replace the Door Bins:

1. Remove the bin by lifting it up and pulling it out.
2. Replace the bin by sliding it in above the desired support and pushing it down until it stops.

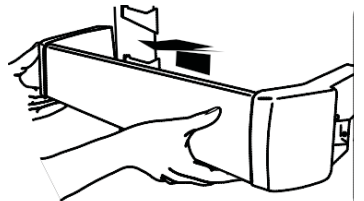

# Freezer Features

## Freezer Pan and Pull-out Ice Bin

The freezer pan can be used to store smaller items. The freezer pan is not removable.

### Remove and Replace the Ice Bin:

1. Slide the ice bin out of the freezer and lift up and out.
2. To replace the ice bin, pull out the pan slides until they are fully extended and set ice bin on the slides. Push the ice bin in toward the back until it is in closed position.
3. Reopen the ice bin to make sure it has been replaced properly.

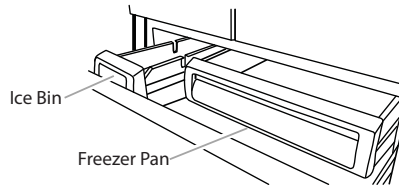

## Frozen Food Storage Guide

Storage times will vary according to the quality and type of food, the type of packaging or wrap used (should be airtight and moisture-proof), and the storage temperature. Ice crystals inside a sealed package are normal. This simply means that moisture in the food and air inside the package have condensed, creating ice crystals.

Put no more unfrozen food into the freezer than will freeze within 24 hours (no more than 2 to 3 lbs of food per cubic foot [907-1,350 g per 28 L] of freezer space). Leave enough space in the freezer for air to circulate around packages. Be sure to leave enough room for the door to close tightly.

For more information on preparing food for freezing, check a freezer guide or reliable cookbook.

## Cleaning and Maintenance

### CAUTION



#### Explosion Hazard

Use non-flammable cleaners.  
Failure to do so can result in death, explosion,  
or fire.

Both the refrigerator and freezer sections defrost automatically. However, clean both sections about once a month to avoid buildup of odors. Wipe up spills immediately.

#### To Clean Your Refrigerator:

1. Remove the top grille. See "Power On/Off Switch."
2. Press power switch to OFF.
3. Remove all removable parts from inside, such as shelves, crispers, etc.
4. Hand wash, rinse, and dry removable parts and interior surfaces thoroughly. Use a clean sponge or soft cloth and a mild detergent in warm water.
  - Do not use abrasive or harsh cleaners such as window sprays, scouring cleansers, flammable fluids, cleaning waxes, concentrated detergents, bleaches or cleansers containing petroleum products on plastic parts, interior and door liners or gaskets. Do not use paper towels, scouring pads, or other harsh cleaning tools. These can scratch or damage materials.
  - To help remove odors, you can wash interior walls with a mixture of warm water and baking soda (2 tbs to 1 qt [26 g to 0.95 L] of water).
5. Clean the exterior surfaces.
  - To keep your stainless steel refrigerator looking like new and to remove minor scuffs or marks, use a Stainless Steel Cleaner and Polish.  
**IMPORTANT:** Do not allow the Stainless Steel Cleaner and Polish to come into contact with any plastic parts such as the trim pieces, dispenser covers or door gaskets. If unintentional contact does occur, clean plastic part with a sponge and mild detergent in warm water. Dry thoroughly with a soft cloth. To order the cleaner, see "Accessories."
6. Press the power switch to ON.
7. Replace the top grille. See "Power On/Off Switch."

## Cleaning and Maintenance

### Changing the Light Bulbs

**NOTE:** Not all appliance bulbs will fit your refrigerator. Be sure to replace the bulb with one of the same size and shape. The lights require a 40-watt maximum appliance bulb. Replacement bulbs are available from your dealer.

### Refrigerator Lights

There are three light bulbs located in the top front of the refrigerator compartment behind a light shield.

1. Remove the top grille. See "Power On/Off Switch."
2. Press power switch to the Off position.
3. Open the light shield. Grasp the light shield by the openings. Gently push back and pull down, as shown, to access the light bulbs.

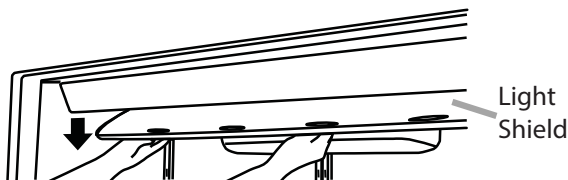

4. Remove the light bulb and replace it with one of the same size, shape and wattage.
5. Close the light shield by raising it up into place.  
**NOTE:** If needed, clean the light shield with a damp soft cloth.
6. Press the power switch to the On position.
7. Replace the top grille. See "Power On/Off Switch."

### Freezer Lights

There are two light bulbs located in the top of the freezer compartment. One bulb is over the ice bin, and the other bulb is over the freezer pan.

1. Slide open the ice bin or freezer pan to access the light bulb.
2. Remove the light bulb and replace it with one of the same size, shape and wattage.

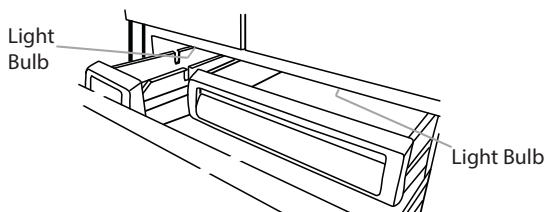

# Cleaning and Maintenance

## Power Interruptions

If the power will be out for 24 hours or less, keep the door or doors closed (depending on your model) to help food stay cold and frozen.

If the power will be out for more than 24 hours, do one of the following:

- Remove all frozen food and store it in a frozen food locker.
- Place 2 lbs (907 g) of dry ice in the freezer for every cubic foot (28 L) of freezer space. This will keep the food frozen for 2 to 4 days.
- If neither a food locker nor dry ice is available, consume or can perishable food at once.

**REMEMBER:** A full freezer stays cold longer than a partially filled one. A freezer full of meat stays cold longer than a freezer full of baked goods. If you see that food contains ice crystals, it may be refrozen, although the quality and flavor may be affected. If the condition of the food is poor, dispose of it.

## Vacation Care

Your refrigerator is equipped with the Rest Mode feature, which is designed for the traveler who wishes to turn off the lights and ice maker. By selecting this feature, the temperature set points remain unchanged, the ice maker will be disabled and the interior lights will turn off. For most efficient refrigerator operation, it is recommended to exit the Rest Mode when it is no longer required.

### If You Choose to Leave the Refrigerator on While You're Away:

1. Use up any perishables and freeze other items.
2. Press REST MODE pad.
3. If your refrigerator has an automatic ice maker, shut off the water supply to the ice maker.
4. Empty the ice bin.
5. When you return from vacation, press REST MODE to return to normal operation.

### If You Choose to Turn the Refrigerator Off Before You Leave:

1. Remove all food from the refrigerator.
2. If your refrigerator has an automatic ice maker:
  - Turn off the water supply to the ice maker at least one day ahead of time.
  - When the last load of ice drops, slide the ice maker control to the OFF (down) position.
3. Depending on your model, turn the Thermostat Control (or Refrigerator Control) to OFF. See "Using the Controls."
4. Clean refrigerator, wipe it, and dry well.
5. Tape rubber or wood blocks to the tops of all doors to prop them open far enough for air to get in. This stops odor and mold from building up.

# Troubleshooting

## ⚠ WARNING



### Electrical Shock Hazard

Plug into a grounded 3 prong outlet.  
 Do not remove ground prong.  
 Do not use an adapter.  
 Do not use an extension cord.  
 Failure to follow these instructions can result in death, fire, or electrical shock.

### Refrigerator Operation

Problem	Cause	Solution
The refrigerator will not operate	Power cord unplugged? Is outlet working? Household fuse blown or circuit breaker tripped? Are controls on? Is refrigerator defrosting? New installation?	Plug into a grounded 3-prong outlet. Plug in a lamp to see if the outlet is working. Replace the fuse or reset the circuit breaker. If the problem continues, call an electrician. Make sure the refrigerator controls are on. See "Using the Controls". Allow 24 hours following installation for the refrigerator to cool completely. <b>Note:</b> Adjusting the temperature controls to coldest setting will not cool either compartment more quickly.
The motor seems to run too much	Normal operation	Your new refrigerator may run longer than your old one due to its high-efficiency compressor and fans. The refrigerator may run even longer if the room is warm, a large food load is added, doors are opened often, or if the doors have been left open.

## Troubleshooting (cont.)

### Refrigerator Operation

Problem	Cause	Solution
The refrigerator seems noisy	Refrigerator noise has been reduced over the years. Due to this reduction, you may hear intermittent noises from your new refrigerator that you did not notice from your old model. Listed on the right are some normal sounds with explanations.	<p>Buzzing—heard when the water valve opens to fill the ice maker</p> <p>Pulsating—fans/compressor adjusting to optimize performance</p> <p>Hissing/Rattling—flow of refrigerant, movement of water lines, or from items placed on top of the refrigerator</p> <p>Sizzling/Gurgling—water dripping on the heater during defrost cycle</p> <p>Popping—contraction/expansion of inside walls, especially during initial cool-down</p> <p>Water running—may be heard when water melts during the defrost cycle and runs into the drain pan</p> <p>Creaking/Cracking—occurs as ice is being ejected from the ice maker mold.</p>
The doors will not close completely	<p>Door blocked open?</p> <p>Bin or shelf in the way?</p>	<p>Move food packages away from door.</p> <p>Push bin or shelf back in the correct position.</p>
The doors are difficult to open	Gaskets dirty or sticky?	Clean gaskets and contact surfaces with mild soap and warm water. Rinse and dry with soft cloth.

### **WARNING**



#### **Explosion Hazard**

Use non-flammable cleaners. Failure to do so can result in death, explosion, or fire.

## Troubleshooting (cont.)

### Lights

Problem	Cause	Solution
Lights do not work.	Is a light bulb loose in the socket or burned out? Is the refrigerator in Rest Mode? Has the door been open more than 10 minutes?	See "Changing the Light Bulbs" See 'Using the Controls"  See 'Using the Controls"

### Temperature and Moisture

Problem	Cause	Solution
Temperature is too warm	New installation?  Door(s) opened often or left open?  Large load of food added?  Controls set correctly for the surrounding conditions?  Refrigerator not cooling?  Air vents blocked?	Allow 24 hours following installation for the refrigerator to cool completely. Allows warm air to enter refrigerator. Minimize door openings and keep doors fully closed. Allow several hours for refrigerator to return to normal temperature. Adjust the controls a setting colder. Check temperature in 24 hours. See "Using the Controls". Turn the refrigerator OFF an then ON to reset. If this does not correct the problem, call for service. Remove any item from in front of the air vents.
There is interior moisture buildup <b>Note:</b> Some moisture buildup is normal.	Humid room?  Door(s) left open?  Energy Saver on?	Contributes to moisture buildup. Allows humid air to enter refrigerator. Minimize door openings and keep door(s) fully closed. Turn the Energy Saver feature OFF, if moisture is collecting between the refrigerator doors. See "Using the Controls".



## Troubleshooting (cont.)

### Ice and Water

Problem	Cause	Solution
The ice maker is not producing ice or not enough ice	Refrigerator connected to a water supply and the supply shutoff valve turned on? Kink in the water source line?  Ice maker turned on?  New installation?  Large amount of ice recently removed? Ice cube jammed in the ice maker ejector arm? Reverse osmosis water filtration system connected to your cold water supply?	Connect refrigerator to water supply and turn water shutoff valve fully open. A kink in the line can reduce water flow. Straighten the water source line. Make sure switch is in the ON position. Wait 24 hours after ice maker installation for ice production to begin. Wait 72 hours for full ice production. Allow 24 hours for ice maker to produce more ice. Remove ice from the ejector arm with a plastic utensil. This can decrease water pressure. See "Water Supply Requirements".
The ice cubes are hollow or small <b>Note:</b> <i>This is an indication of low water pressure.</i>	Water shutoff valve not fully open? Kink in the water source line?  Reverse osmosis water filtration system connected to your cold water supply?	Turn the water shutoff valve fully open. A kink in the line can reduce water flow. Straighten the water source line. This can decrease water pressure. See "Water Supply Requirements".
Ice is sticking together in the ice storage bin.	It is normal for frost to be on top of the ice storage bin due to normal opening and closing of the freezer. It is normal for ice to stick together when it is not dispensed or used frequently.	It is recommended tht the ice storage bin be emptied and cleaned as needed. See "Ice Maker"

## Troubleshooting (cont.)

### Ice and Water

Problem	Cause	Solution
Off-taste, odor or gray color in the ice	New plumbing connections?  Ice stored too long?  Odor transfer from food?  Are there minerals (such as sulfur) in the water?  Water filter installed on the refrigerator?	New plumbing connections can cause discolored or off-flavored ice. Discard ice. Wash ice bin. Allow 24 hours for ice maker to make new ice. Use airtight, moisture proof packaging to store food. A water filter may need to be installed to remove the minerals. Gray or dark discoloration in ice indicates that the water filtration system needs additional flushing.

## Service Information

If service is required after checking the troubleshooting guide, call your dealer or authorized service agency. The name of the authorized service agency can be obtained from the dealer or distributor in your area.

When you make a service call, be sure to have the following information handy:

- Model Number
- Serial Number
- Date of Purchase
- Name of dealer from whom purchased

Be ready to clearly describe the problem that you are having with your refrigerator.

If you are unable to obtain the name of an authorized service agency, or if you continue to have service problems, contact Viking Range, LLC at (888) 845-4641 or write to:

**VIKING RANGE, LLC  
PREFERRED SERVICE  
111 Front Street  
Greenwood, Mississippi 38930 USA**

Record the following information indicated below. You will need it if service is ever required.

The serial number and model numbers for your refrigerator are located on the upper wall, behind the lighting:

Model No. \_\_\_\_\_ Serial No. \_\_\_\_\_

Date of Purchase \_\_\_\_\_ Date Installed \_\_\_\_\_

Dealer's Name \_\_\_\_\_

Address \_\_\_\_\_

\_\_\_\_\_

If service requires installation of parts, use only authorized parts to insure protection under the warranty.

**Keep this manual with your refrigerator for future reference.**

# Warranty

## **FREESTANDING FRENCH DOOR BOTTOM MOUNT REFRIGERATOR/FREEZER WARRANTY THREE YEAR FULL WARRANTY**

Freestanding french door bottom mount refrigerator/freezers and all of their component parts, **except as detailed below\*\***, are warranted to be free from defective materials or workmanship in normal residential use for a period of three (3) years from the date of original retail purchase or closing date for new construction, whichever period is longer. Viking Range, LLC, warrantor, agrees to repair or replace, at its option, any part which fails or is found to be defective during the warranty period.

**\*FULL NINETY (90) DAY COSMETIC WARRANTY:** Product is warranted to be free from cosmetic defects in materials or workmanship (such as scratches on stainless steel, paint/porcelain blemishes, etc.) for a period of ninety (90) days from the date of original retail purchase or closing date for new construction, whichever period is longer. Any defects must be reported to the selling dealer within ninety (90) days from date of original retail purchase. Viking Range, LLC uses high quality processes and materials available to produce all color finishes. However, slight color variation may be noticed because of the inherent differences in painted parts and porcelain parts as well as differences in kitchen lighting, product locations, and other factors. Therefore, this warranty does not apply to color variation attributable to such factors.

**†FULL NINETY (90) DAY WARRANTY IN "RESIDENTIAL PLUS" APPLICATIONS:** This full warranty applies to applications where use of the product extends beyond normal residential use, but the warranty period for products used in such applications is ninety (90) days. Examples of applications covered by this warranty are bed and breakfasts, fire stations, private clubs, churches, yachts, etc. Under this "Residential Plus" warranty, the product, its components and accessories are warranted to be free from defective material or workmanship for a period of ninety (90) days from the date of original retail purchase. This warranty excludes use of the product in all commercial locations such as restaurants, food service locations and institutional food service locations.

## **SIX YEAR FULL WARRANTY ON SEALED REFRIGERATION PARTS AS LISTED**

Any sealed refrigeration system component, as listed below, is warranted to be free from defective materials or workmanship in normal household use during the fourth through the sixth year from the date of original retail purchase. Viking Range, LLC, warrantor, agrees to repair or replace, at its option, any part which fails or is found to be defective during the warranty period.

**Sealed Refrigeration System Components:** Compressor, Evaporator, Condenser, Connecting Tubing, Dryer/Strainer

## **TWELVE YEAR LIMITED WARRANTY ON SEALED REFRIGERATION PARTS AS LISTED**

Any sealed refrigeration system component, as listed above, which fails due to defective materials or workmanship in normal household use during the seventh through the twelfth year from the date of original retail purchase will be repaired or replaced, free of charge for the part itself, with the owner paying all other costs, including labor.

## **TERMS AND CONDITIONS**

This warranty extends to the original purchaser of the product warranted hereunder and to each transferee owner of the product during the term of the warranty and applies to products purchased and located in the United States, Canada, Mexico, and the Caribbean (excluding Cuba, Dominican Republic, and Haiti). Products must be purchased in the country where service is requested. If the product or one of its component parts contains a defect or malfunction during the full warranty period after a reasonable number of attempts by the warrantor to remedy the defect or malfunction, the owner is entitled to either a refund or replacement of the product or its component part or parts. Replacement of a component part includes its free installation, except as specified under the limited warranty. Under the terms of this warranty, service must be performed by a factory authorized Viking Range, LLC service agent or representative. Service will be provided during normal business hours, and labor performed at overtime or premium rates shall not be covered by this warranty.

Owner shall be responsible for proper installation, providing reasonable and necessary maintenance, providing proof of purchase upon request, and making the appliance reasonably accessible for service. The return of the Owner Registration Card is not a condition of warranty coverage. You should, however, return the Owner Registration Card so that Viking Range, LLC can contact you should any question of safety arise which could affect you.

This warranty gives you specific legal rights, and you may also have other rights which may vary from jurisdiction to jurisdiction.

## Warranty (cont.)

**WHAT IS NOT COVERED BY THIS WARRANTY:** This warranty shall not apply to damage resulting from abuse, failure to provide reasonable and necessary maintenance, accident, delivery, negligence, natural disaster, loss of electrical power to the product for any reason, alteration, outdoor use, improper installation, improper operation, or repair or service of the product by anyone other than an authorized Viking Range, LLC service agency or representative. This warranty does not apply to commercial usage.

**LIMITATION OF REMEDIES AND DURATION OF IMPLIED WARRANTY OWNER'S SOLE AND EXCLUSIVE REMEDY FOR A CLAIM OF ANY KIND WITH RESPECT TO THIS PRODUCT SHALL BE THE REMEDIES SET FORTH ABOVE. VIKING RANGE IS NOT RESPONSIBLE FOR CONSEQUENTIAL OR INCIDENTAL DAMAGE, INCLUDING BUT NOT LIMITED TO FOOD OR MEDICINE LOSS, DUE TO PRODUCT FAILURE, WHETHER ARISING OUT OF BREACH OF WARRANTY, BREACH OF CONTRACT OR OTHERWISE.** Some jurisdictions do not allow the exclusion or limitation of incidental or consequential damages, so the above limitation or exclusions may not apply to you. **ANY IMPLIED WARRANTIES OF MERCHANTABILITY OR FITNESS FOR A PARTICULAR PURPOSE APPLICABLE TO THIS PRODUCT ARE LIMITED IN DURATION TO THE PERIOD OF COVERAGE OF THE APPLICABLE EXPRESS WRITTEN LIMITED WARRANTIES SET FORTH ABOVE.** Some states do not allow limitations on how long an implied warranty lasts, so the above limitation may not apply to you.

#### **WARRANTY SERVICE**

To obtain warranty service, contact an authorized Viking Range, LLC service agent, or Viking Range, LLC, 111 Front Street, Greenwood, Mississippi 38930, (888) 845-4641. Provide model and serial number and date of original purchase or closing date for a new construction. For the name of your nearest authorized Viking Range, LLC service agency, call Viking Range, LLC.

**IMPORTANT:** Retain proof of original purchase to establish warranty period.

**Specifications subject to change without notice.**







Viking Range, LLC  
111 Front Street  
Greenwood, Mississippi 38930 USA  
(662) 455-1200

For product information, call  
1-888-(845-4641) or visit our web site at [vikingrange.com](http://vikingrange.com) in the US or  
[brigade.ca](http://brigade.ca) in Canada

F21309A EN

(103114)