



# **AGA DUAL CONTROL**

**Model No. - DC3 & DC5**

## *Installation Guide*

**PLEASE READ THESE INSTRUCTIONS BEFORE COMMENCING SITE SURVEY  
OR INSTALLING THIS APPLIANCE.**

**IMPORTANT : SAVE INSTRUCTIONS FOR FUTURE REFERENCE**

**IMPORTANT : CONSERVER CES INSTRUCTIONS POUR REFERENCE FUTURE**

# CONTENTS

<b>SECTION</b>	<b>PAGE</b>
PRODUCT SAFETY	3
GENERAL NOTES	4
DELIVERY REQUIREMENTS	4
GENERAL INSTALLATION REQUIREMENTS	4
APPLIANCE DIMENSIONS - AGA DC3	5
APPLIANCE DIMENSIONS - AGA DC5	6
INSTALLATION	7 - 8
CONNECTION TO THE POWER SUPPLY - AGA DC3	9
POWER SUPPLY - HOT CUPBOARD AGA DC5	10
MAINS SUPPLY LOCATION - AGA DC3	11
MAINS SUPPLY LOCATION - AGA DC5	12
HOTCUPBOARD INSTALLATION	13 - 19
WIRING DIAGRAM - AGA DC3	20
WIRING DIAGRAM - AGA DC5	21
INSTRUCTIONS	22

## PRODUCT SAFETY

MEANING/DESCRIPTION	SYMBOL	SIGNIFICATION/DESCRIPTION
<p><b>WARNING/CAUTION</b></p> <p>An appropriate safety instruction should be followed or caution to a potential hazard exists.</p>		<p><b>AVERTISSEMENT</b></p> <p>Une consigne de sécurité appropriée doivent être suivies ou garde d'un danger potentiel exists.</p>
<p><b>DANGEROUS VOLTAGE</b></p> <p>To indicate hazards arising from dangerous voltages.</p>		<p><b>TENSION DANGEREUSE</b></p> <p>Pour indiquer les dangers résultant des tensions dangereuses.</p>
<p><b>PROTECTIVE EARTH (GROUND)</b></p> <p>To identify any terminal which is intended for connection to an external conductor for protection against electric shock in case of a fault, or the terminal of a protective earth (ground) electrode.</p>		<p><b>TERRE DE PROTECTION</b></p> <p>Pour marquer bornes destinées à être raccordées à un conducteur de protection extérieur contre les chocs électiques en cas de défaut d'isolement, ou pour marquer la borne de la terre de protection.</p>
<p><b>HEAVY</b></p> <p>This product is heavy and reference should be made to the safety instructions for provisions of lifting and moving.</p>		<p><b>LOURD</b></p> <p>Ce produit est lourd et doit être fait référence aux consignes de sécurité relatives aux dispositions de soulever et déplacer.</p>
<p><b>DISCONNECT MAINS SUPPLY</b></p> <p>Disconnect incoming supply before inspection or maintenance.</p>		<p><b>APPAREIL À LASER DE CLASSE 2</b></p> <p>Alimentation d'entrée Débrancher avant inspection ou d'entretien.</p>
<p><b>REFER TO MANUAL</b></p> <p>Refer to relevant instructions detailed within the product manual.</p>		<p><b>ATTENTION, SURFACE TRÈS CHAUDE</b></p> <p>Reportez-vous aux instructions applicables, indiquées dans le manuel du produit.</p>

## GENERAL NOTES

**NOTE:** THESE INSTALLATION INSTRUCTIONS SHOULD BE LEFT WITH THE RANGE AND THE USER TO RETAIN FOR FUTURE REFERENCE.

## DELIVERY REQUIREMENTS

The AGA DC3 arrives on 1 pallet.

The AGA DC5 (Hotcupboard Option) arrives on 2 pallets.

There must be access to the kitchen to manipulate a foot print of 39 <sup>9</sup>/<sub>16</sub>" (1005mm) x 29 <sup>1</sup>/<sub>8</sub>" (740mm). A wooden template (skate with castor wheels) of dimensions 39 <sup>9</sup>/<sub>16</sub>" (1005mm) x 29 <sup>1</sup>/<sub>8</sub>" (740mm) could be used to check if the AGA Dual Control fully built appliance is able to fit through the property grounds and doors into its installation position in the kitchen. It must also be considered that the height of the appliance is 37 <sup>3</sup>/<sub>4</sub>" (960mm) off pallet and 43 <sup>1</sup>/<sub>4</sub>" (1100mm) on the pallet, so high level obstacles/restrictions must not be overlooked.

If this skate/template **can** be manipulated through the property grounds and doors into position, then the AGA Dual Control can be installed as intended with no re-work.

## GENERAL INSTALLATION REQUIREMENTS

The installation of the range must be in accordance with the relevant requirements of the local Wiring and Building Regulations. It should be in accordance also with any relevant requirements of the Local Authority.

In your own interest and that of safety to comply with the law, all appliances should be installed by an authorized AGA distributor in accordance with the relevant regulations.



**CAUTION:**  
**THIS UNIT IS HEAVY, PROPER EQUIPMENT AND ADEQUATE  
MANPOWER MUST BE USED IN MOVING THE RANGE TO  
AVOID DAMAGE TO THE UNIT OR THE FLOOR**

## APPLIANCE DIMENSIONS - AGA DC3

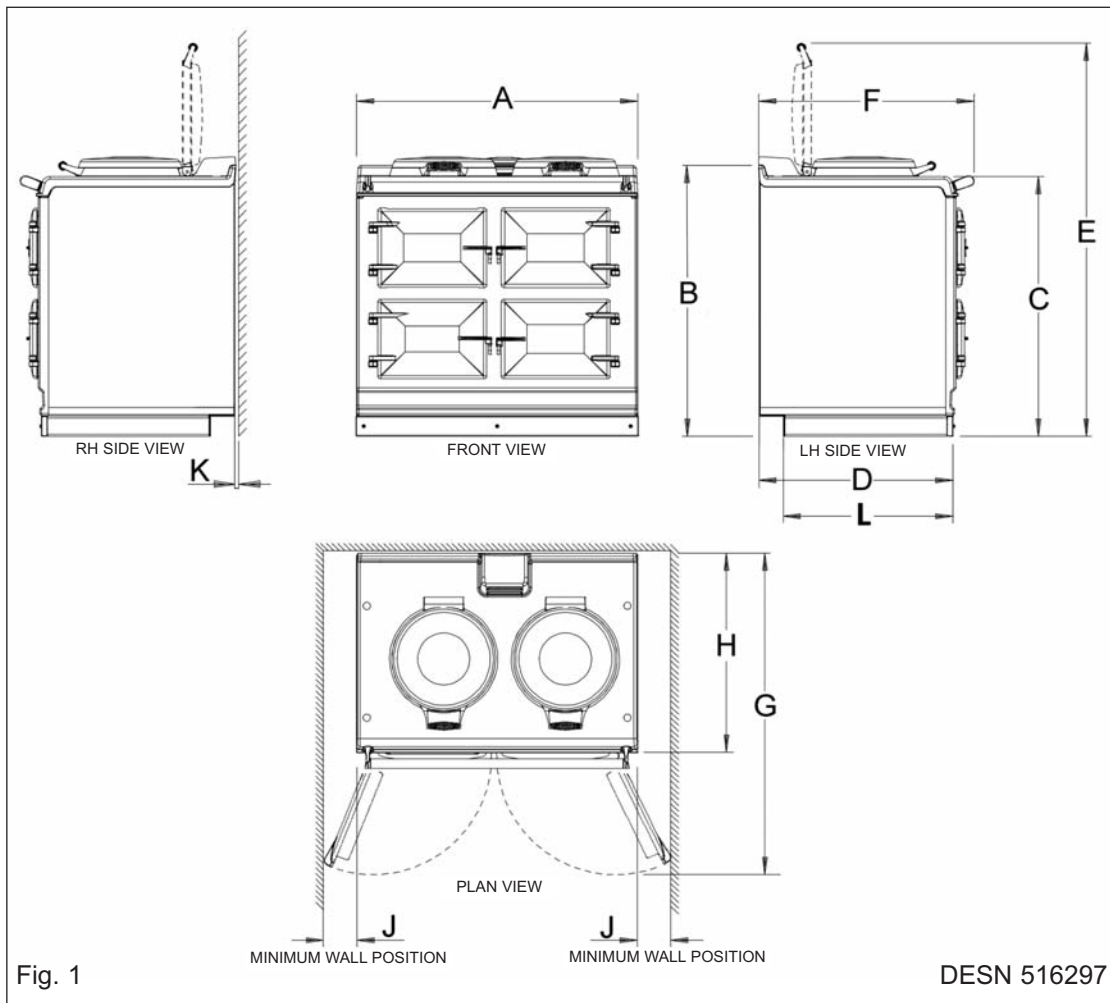

	A	B	C	D	E	F	G	H	J	K	L
mm	987	948	910	680	1388	760	1145	698	116	10	634
pouces	38 <sup>7</sup> / <sub>8</sub>	37 <sup>3</sup> / <sub>8</sub>	35 <sup>7</sup> / <sub>8</sub>	26 <sup>3</sup> / <sub>4</sub>	54 <sup>5</sup> / <sub>8</sub>	29 <sup>7</sup> / <sub>8</sub>	45 <sup>1</sup> / <sub>8</sub>	27 <sup>1</sup> / <sub>2</sub>	4 <sup>5</sup> / <sub>8</sub>	<sup>3</sup> / <sub>8</sub>	25

### Range Dimensions

When surveying for a range installation the actual clearance required for the 'body' of the appliance should be increased by 3/8" (10mm) beyond the figures quoted above. This allows safe margin to take into account the natural dimensional variations found in major castings. In particular the width across the appliance recess could be critical.

### APPLIANCE WEIGHT (Excludes Packaging)

Model: AGA Dual Control (DC3) - 978 lbs

**DATA PLATE LOCATED BEHIND BOTTOM PLINTH.**

## APPLIANCE DIMENSIONS - AGA DC5

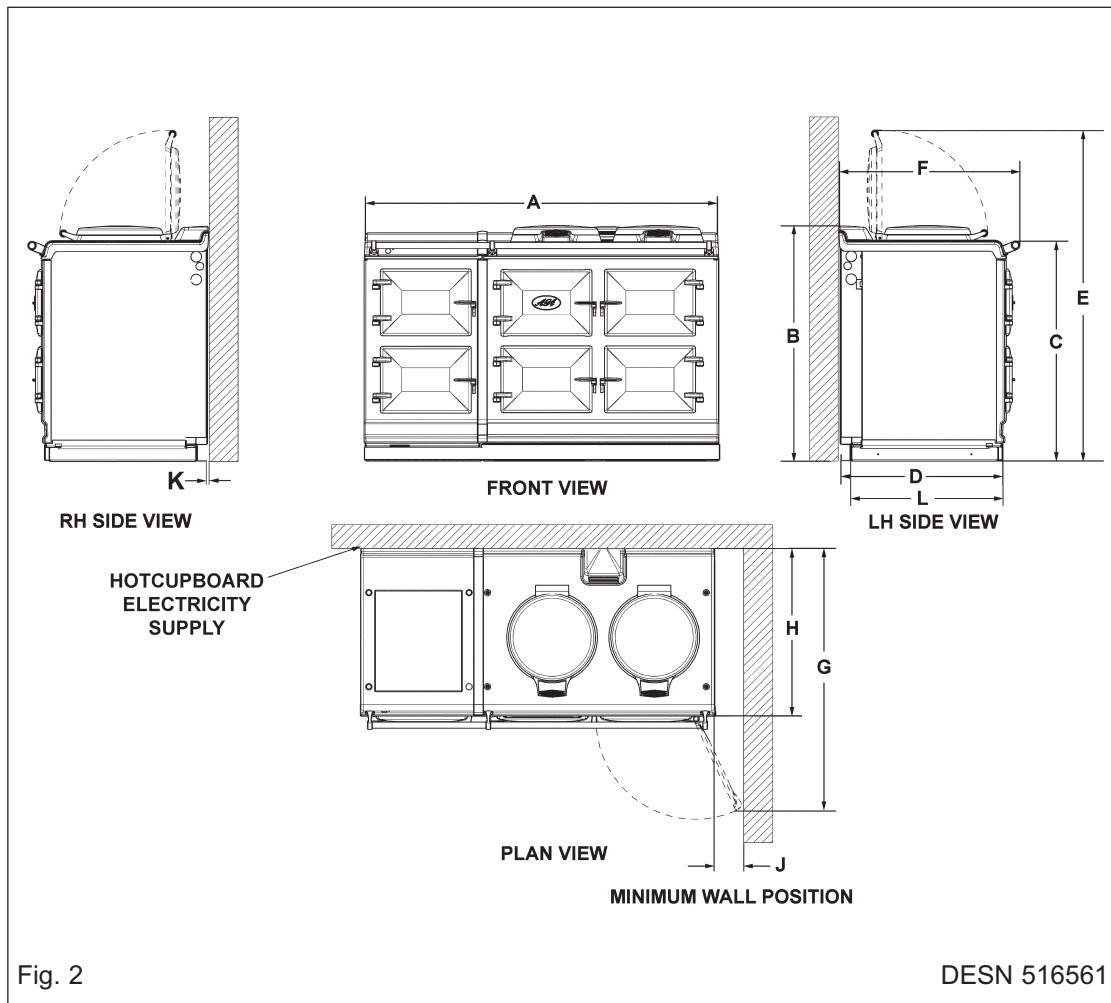

	A	B	C	D	E	F	G	H	J	K	L
mm	1478	948	910	680	1388	760	1145	698	116	10	634
ins	58 1/8	37 3/8	35 7/8	26 3/4	54 5/8	29 7/8	45 1/8	27 1/2	4 5/8	3/8	25

### Range Dimensions

When surveying for a range installation the actual clearance required for the 'body' of the appliance should be increased by 3/8" (10mm) beyond the figures quoted above. This allows safe margin to take into account the natural dimensional variations found in major castings. In particular the width across the appliance recess could be critical.

### APPLIANCE WEIGHT (Excludes Packaging)

Model: AGA Dual Control (DC5) - 978 lbs

Hotcupboard - 242 lbs

**DATA PLATE LOCATED BEHIND BOTTOM PLINTH.**

# INSTALLATION

## Range Base or Hearth

It is essential that the base or hearth on which the range stands should be level and be capable of supporting the total weight of the range. The base of the built-in AGA plinth must be level and sit above finished floor height for service access.

## Plinth

The front plinth cover is removable and must not be obstructed by flooring or tiles. If necessary the range must be raised by the thickness of the tiles to ensure the plinth can be removed.

## Rear Wall

The wall behind the range must be of non-combustible material with a minimum thickness of 1" (25mm).

## Minimum Clearance to Combustibles

A gap of at least  $\frac{1}{2}$ " must be observed between the rear of the top plate, and the wall behind the range. If the rear wall is of combustible material there must be a gap of  $1\frac{1}{2}$ " (38mm).

## Side Clearances

A  $\frac{1}{8}$ " (3mm) gap is required each side between the range top plate and adjoining work surfaces that may be fitted, this is to allow for the safe removal of the top plate should this be required at a later date.

Where ranges are fitted against a side wall a  $4\frac{5}{8}$ " (116mm) side clearance is required on the right and left hand side for oven door access.

If the AGA is to be installed in a brick recess, then the minimum clearance should be increased by at least  $\frac{3}{8}$ " (10mm), to allow for the walls not being square.

In addition a minimum clearance of  $39\frac{3}{8}$ " (1000mm) must be available at the front of the range to enable the range to be serviced.

## Tiling

When the range is to stand in a recess or against a wall which is to be tiled, under no circumstances should the tiles overlap the range top plate, access to remove the hotplate must be allowed for servicing at a later date.

A gap of at least  $\frac{1}{2}$ " (12mm) must be observed between the rear of the top plate and the wall behind the range.

## Overhead Cabinets

To eliminate the risk of burns or fires by reaching over hot surface units, cabinet storage space located above the surface units should be avoided.

## Range Hoods

It is recommended that this AGA is fitted with a range hood. The AGA venting system is located on top of the AGA between the two hotplates, and is designed for venting the moisture from the ovens. The range hood should be positioned not less than the minimum height as recommended by the manufacturer, from the top of the AGA.

**Installation Clearance of Combustible Cabinets Adjacent to Range**

1/2" CLEARANCE TO THE BACK OF THE RANGE MAY BE OBTAINED WHEN INSTALLING THE APPLIANCE AGAINST A NON-COMBUSTIBLE WALL OR IF THE WALL IS BEHIND THE RANGE IS DEEMED COMBUSTIBLE THEN THE MINIMUM SPACING FROM THE BACK OF THE RANGE TO THE NEAREST COMBUSTIBLE WALL IS 1 1/2" (38mm).

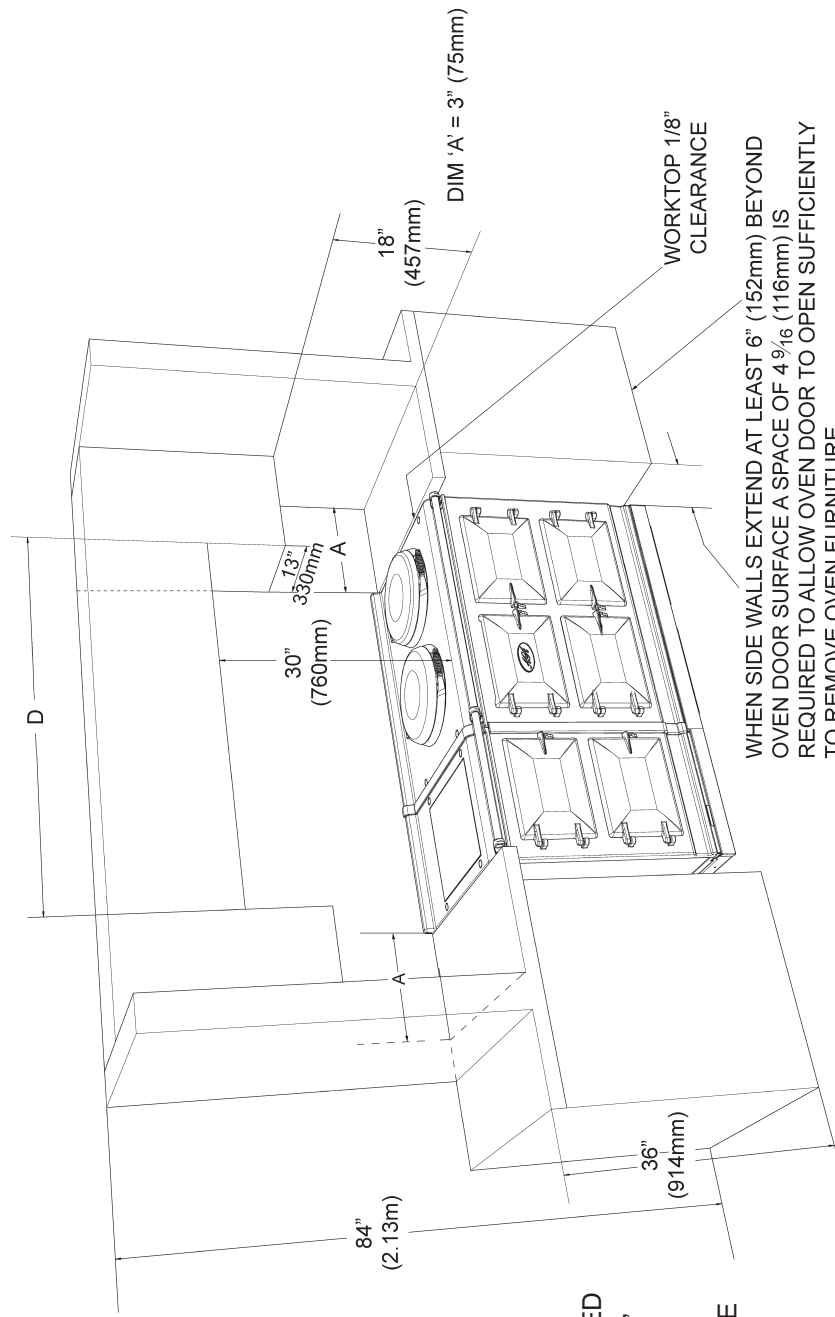

WHEN SIDE WALLS EXTEND AT LEAST 6" (152mm) BEYOND OVEN DOOR SURFACE A SPACE OF 4 9/16" (116mm) IS REQUIRED TO ALLOW OVEN DOOR TO OPEN SUFFICIENTLY TO REMOVE OVEN FURNITURE.

**NOTE:** ANY OVERHEAD FITTED CABINETS MUST NOT EXCEED 13" PROJECTED DEPTH ABOVE THE RANGE. DIM 'D' TO BE NOT LESS THAN THE NORMAL WIDTH OF THE RANGE.

Fig. 3

DESN 51668



## CONNECTION TO THE POWER SUPPLY - AGA DC3



### Electric Shock Hazard



Rating Plate is located behind removable plinth, see Fig. 4.

Electrical Grounding is required on this appliance.

**DO NOT** connect to the electrical supply until the appliance is permanently grounded.

**This appliance must be connected to a grounded metallic permanent supply or a grounding connector should be connected to the grounding terminal or wire lead on the appliance.**

**Failure to follow these instructions could result in death or serious injury.**

This range must be supplied with a 240V, 60Hz power supply and connected to an individual, properly grounded branch circuit protected by a circuit breaker. At 240V, it has a maximum load of 30 amps. Electric hook-up must be done by a licensed electrician. This unit must be installed according to regional codes, or in the absence of codes, the National Electrical Code.

- Product installation requires a separate (not shared) 240V/40 amp circuit protected by an appropriate branch circuit supply.
- The service cord on your range is fitted with a standard four (4) conductor type 14-50P plug (matching receptacle 14-50R).

The method of connection to the mains electricity supply must facilitate complete electrical isolation of the appliance.

The mains connection and isolation should not be positioned above the range and must be positioned within the area defined in Fig. 4, Page 11.

**THIS RANGE MUST BE COMPLETELY ISOLATED FROM THE ELECTRICITY SUPPLY BEFORE SERVICING. THE RANGE IS DESIGNED FOR THE VOLTAGE STATED ON THE RATING PLATE, WHICH IS SITUATED BEHIND THE PLINTH COVER.**

## **POWER SUPPLY - HOTCUPBOARD (AGA DC5)**

**The hotcupboard attachment requires an independent single phase supply. It has a maximum load of 6 amps, protected by an appropriate branch circuit supply.**

110/120V 60 Hz FLEXIBLE CORD and PLUG PARALLEL TYPE (NEMA 5-15P). The appliance when installed must be electrically grounded in accordance with local or regional codes.

An electrical socket must be provided within 5 feet of the LH side of the appliance and easily accessible for the user to disconnect. Do not position socket above the appliance. See Fig. 5A, Page 12.

Take special care when cutting holes in wall or floor. Electrical wires may be behind the wall or floor covering and could cause an electrical shock if you touch them.

Locate any electrical circuits that could be affected by the installation of this product and disconnect power circuit.

### **WARNING Electrical Grounding Instructions**

This appliance is equipped with a NEMA 5-15P grounded plug for your protection against a shock hazard and should be plugged directly into a proper receptacle. Do not cut or remove the grounding prong from this plug.

Do not have a fuse in the neutral or grounding circuit. A fuse in the neutral or grounding circuit could result in electrical shock.

Do not use an extension lead with this appliance.

Check with a qualified electrician, if you are not sure the appliance is properly grounded.

Failure to follow these instructions could result in death or serious injury.

## MAINS SUPPLY LOCATION - AGA DC3

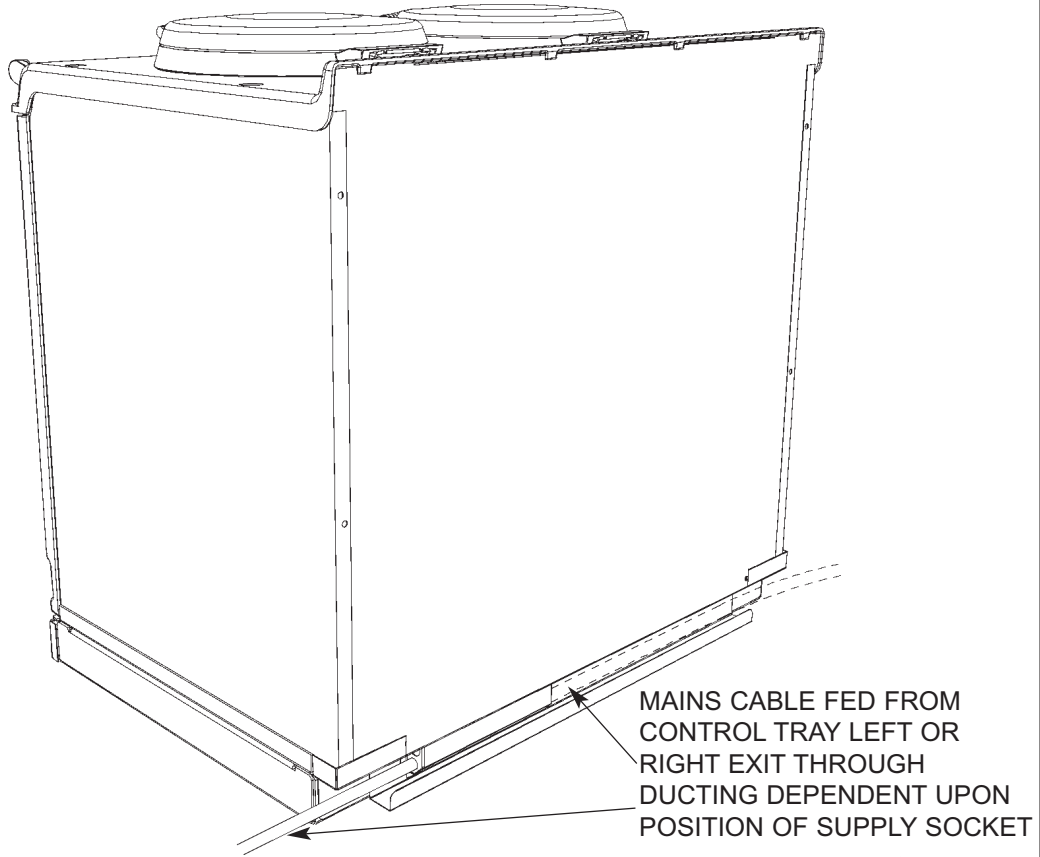
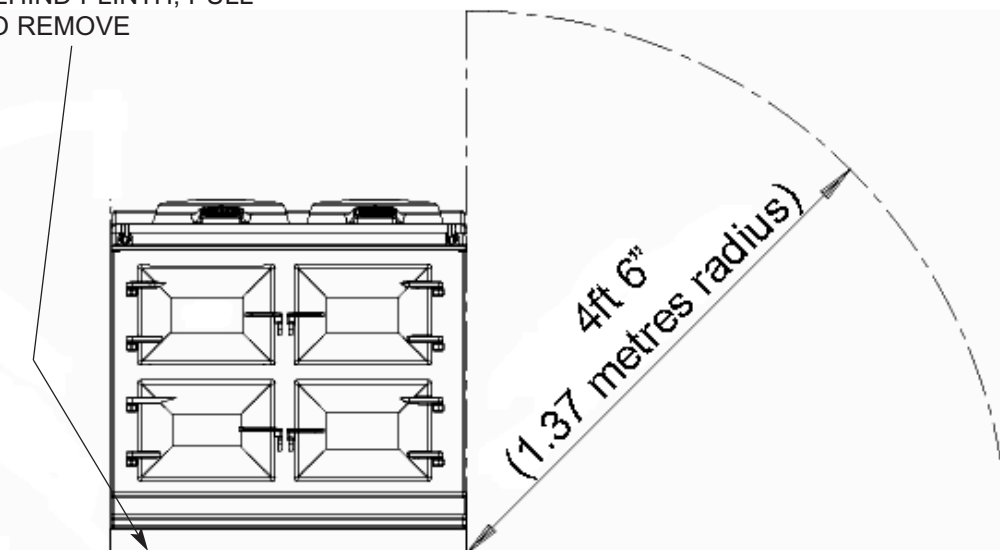

Fig. 3

DESN 516643

RATING LABEL LOCATED BEHIND PLINTH, PULL TO REMOVE



THE MAINS SUPPLY CONNECTION AND ISOLATION POINT MUST BE WITHIN THE ZONE SHOWN

Fig. 4

DESN 516295

# MAINS SUPPLY LOCATION - AGA DC5 (HOTCUPBOARD OPTION)

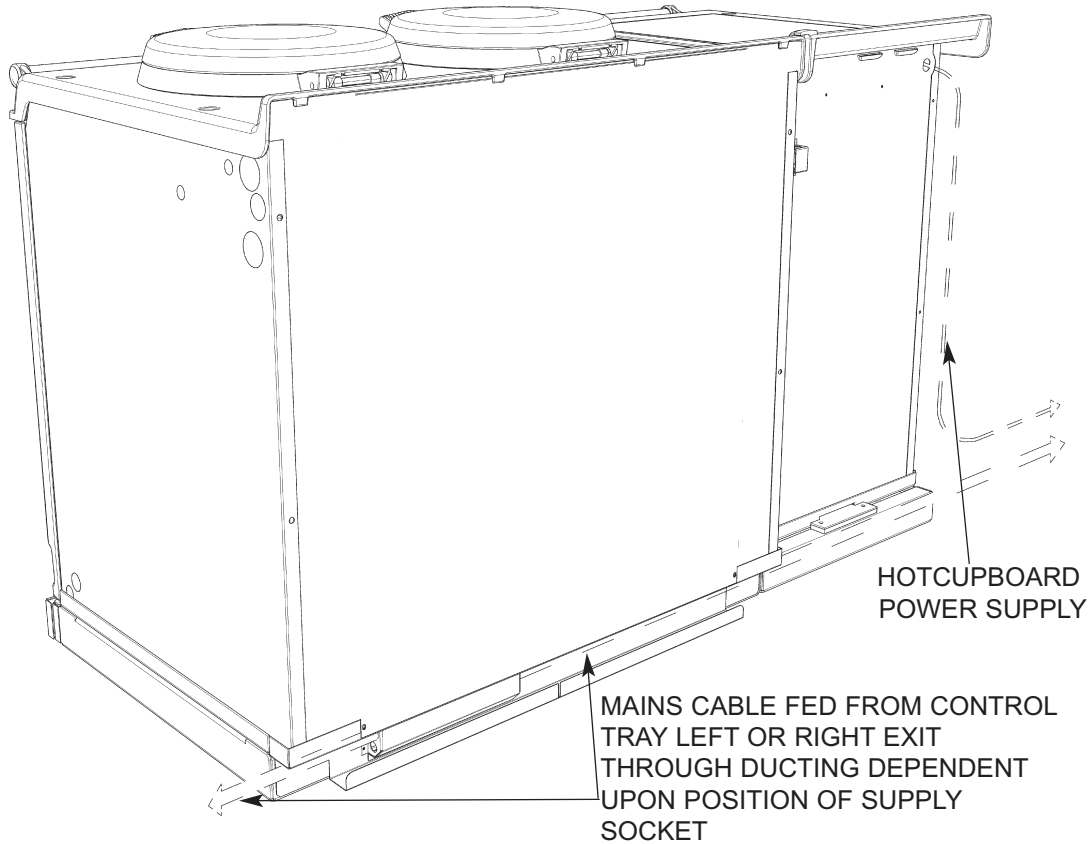
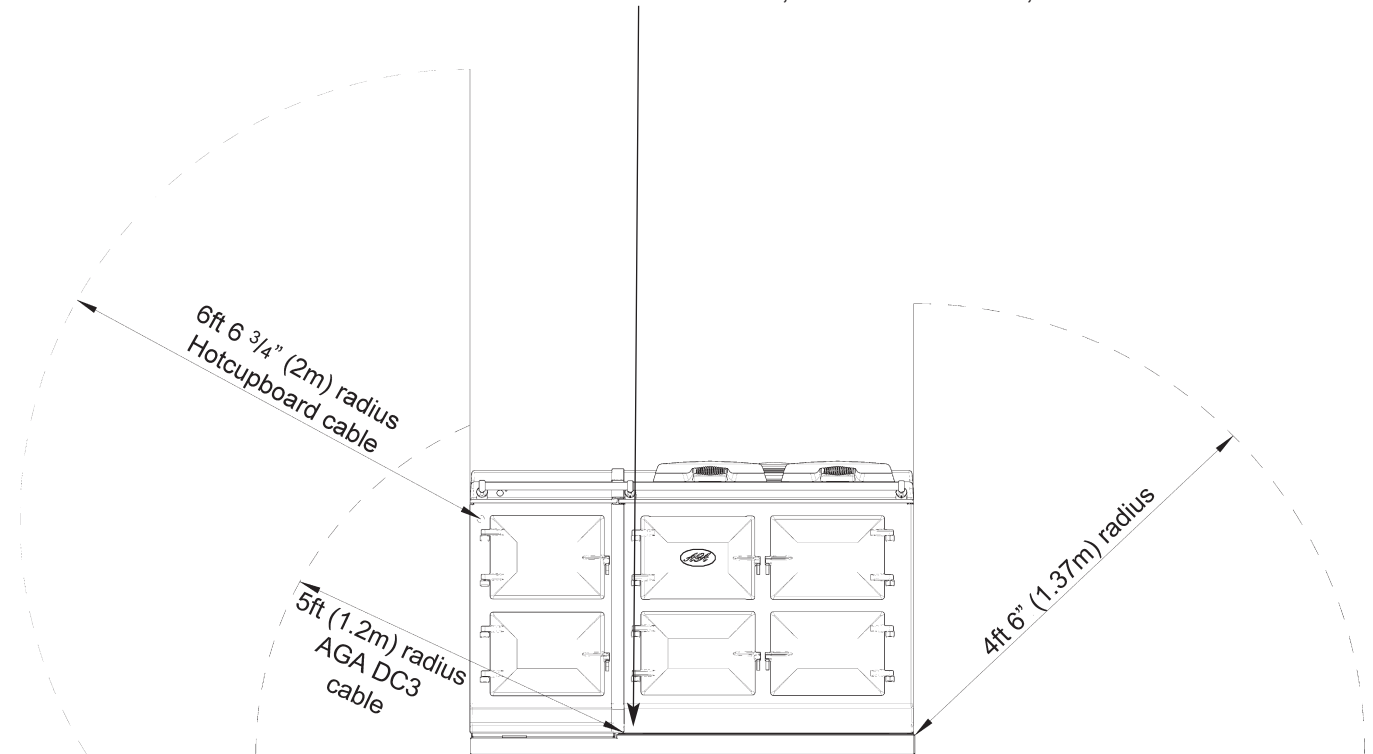

Fig. 5

DESN 516562

RATING LABEL LOCATED BEHIND PLINTH, PULL TO REMOVE,



THE MAINS SUPPLY CONNECT POINT MUST BE WITHIN THE ZONES SHOWN

Fig. 5A

DESN 516590

## HOTCUPBOARD INSTALLATION

**NOTE:** The AGA DC5 hotcupboard should arrive with the top plate in a jacked up position. This is to allow the complete range to be slid onto its plinth when alongside the AGA DC3 without the top plates clashing. The hotcupboard top plate should then be wound down to its correct height once the appliance is in its final position.

1. Detach hotcupboard from plinth by removing two screws and tongue bracket from plinth (See Fig. 6), slide hotcupboard forwards and away from rear fixing bracket (See Fig. 7).

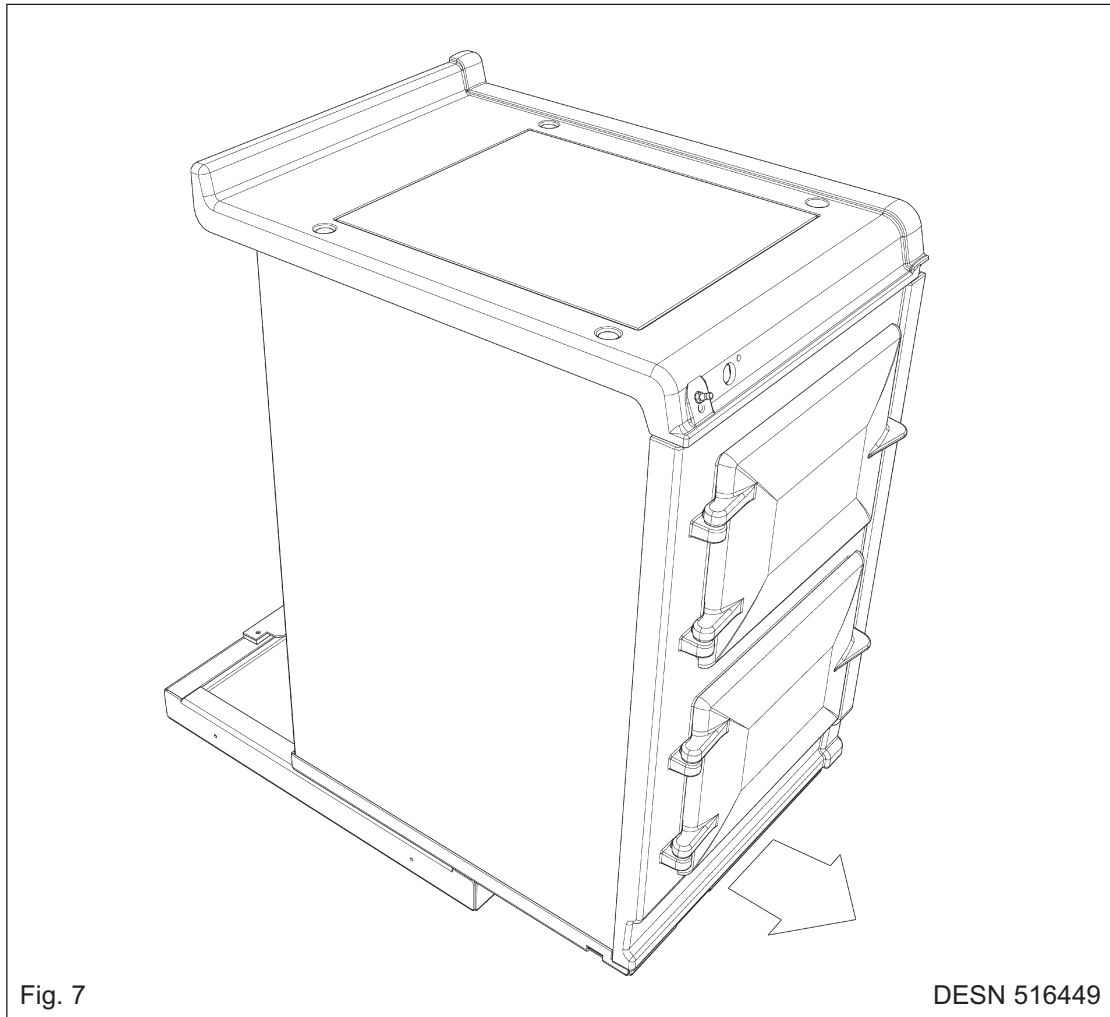
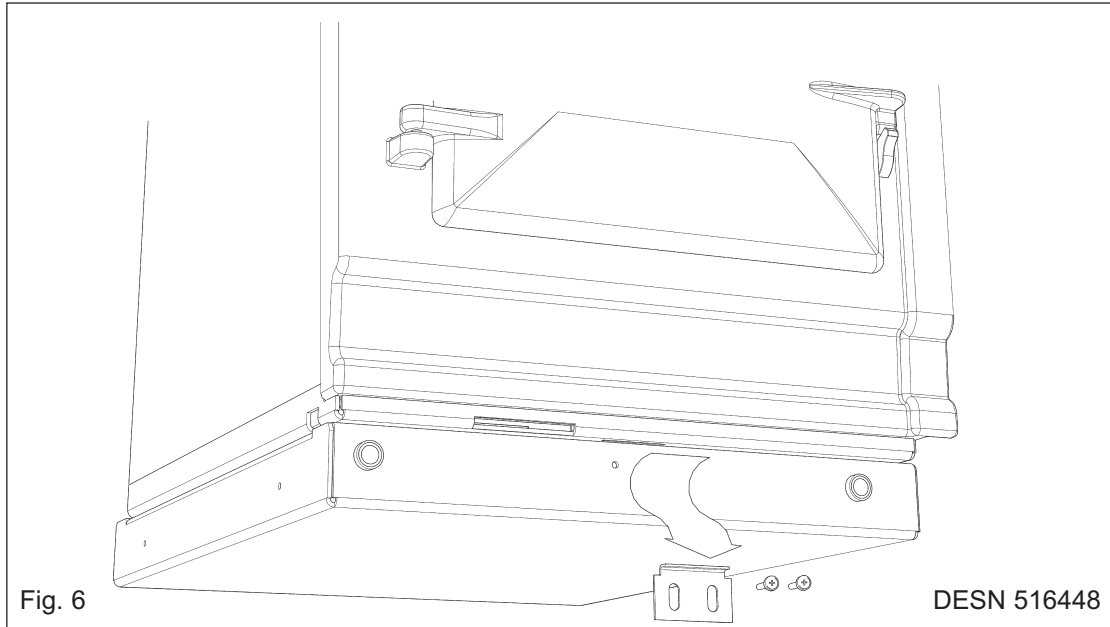

- Position the plinth alongside the AGA Dual Control leaving no gap between the two plinths (See Fig. 8).

Check with a spirit level that the plinth level is correct, and also check height differential between the hotcupboard plinth and Dual Control plinth is correct  $\frac{3}{8}$ " (11mm). If necessary, use shims in each corner to level the plinth.

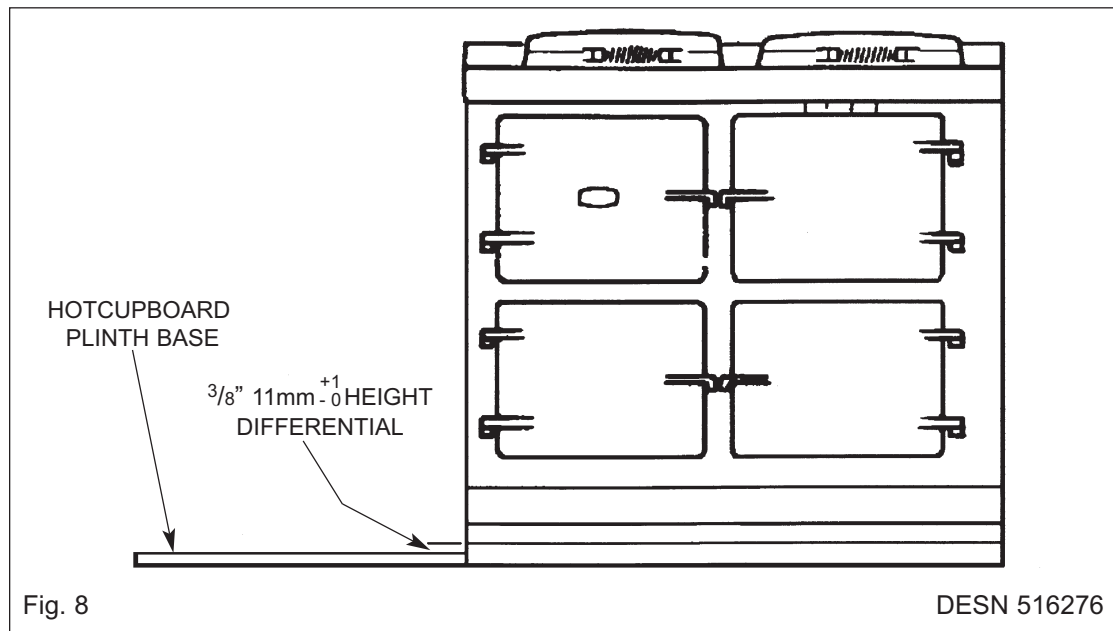

- Attach hotcupboard plinth to the AGA Dual Control plinth using M6 screws and washers provided (See Fig. 9).

Attach locking screw and jacking screw into plinth. Make sure at this stage that the jacking screw does not protrude beyond outer face of plinth. Ensure locking screw is located into AGA DC3 plinth but not fully tightened. A gap of approximately  $\frac{1}{8}$ " (3mm) should be present between the plinths apart from at the very front where the hotcupboard spacer plate should be touching the AGA DC3 plinth.

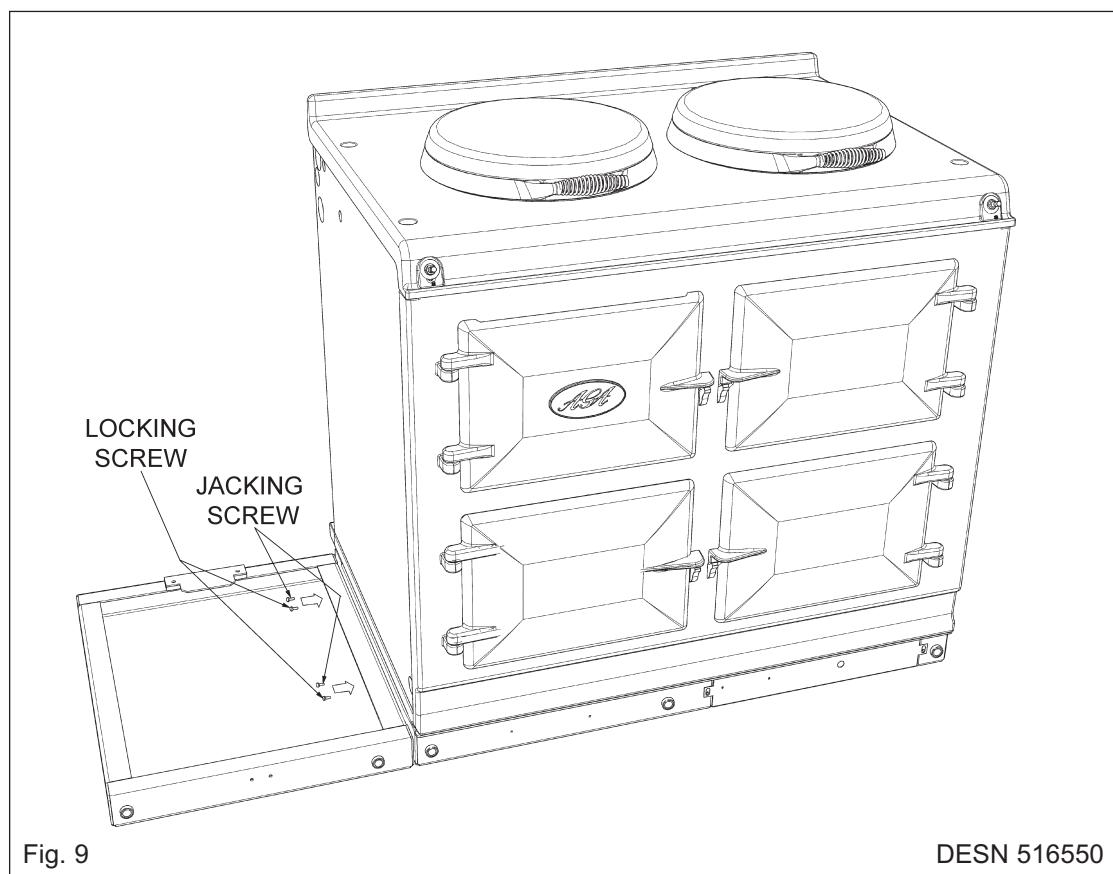

4. Run a straight edge along the front of the AGA Dual Control plinth, to ensure the front face of both plinths sit squarely against the straight edge. (See Fig. 10)

When satisfied both plinths sit squarely, jacking screws can be tightened until they just make contact with the AGA Dual Control plinth, and locking screws can now be tightened.

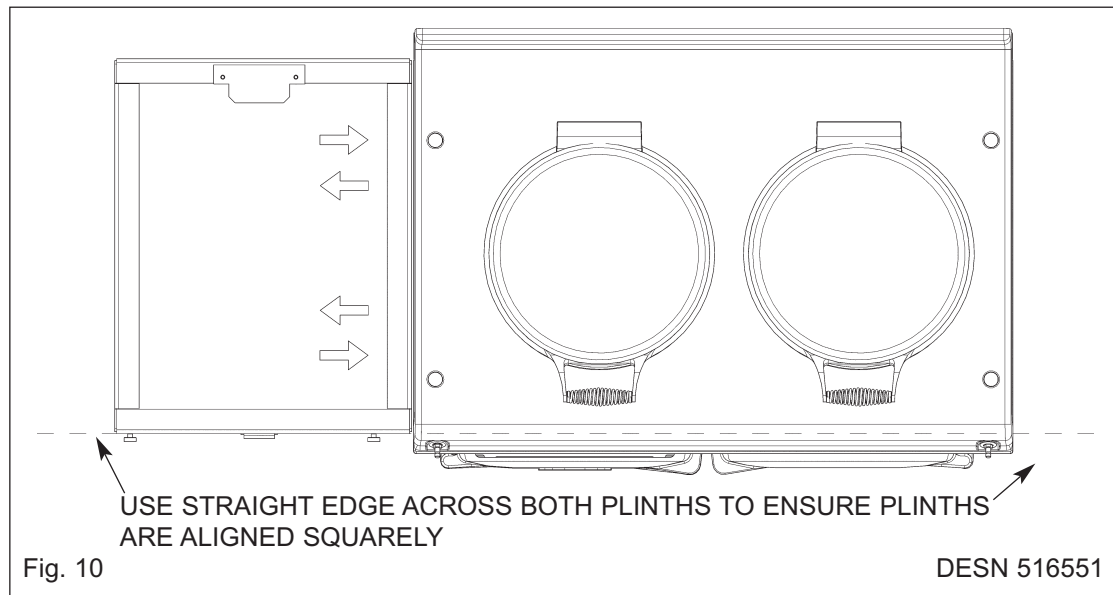

5. Front jointing bracket can now be hooked into place over the two pot magnets. This will latch the two plinths together. (See Fig. 11)

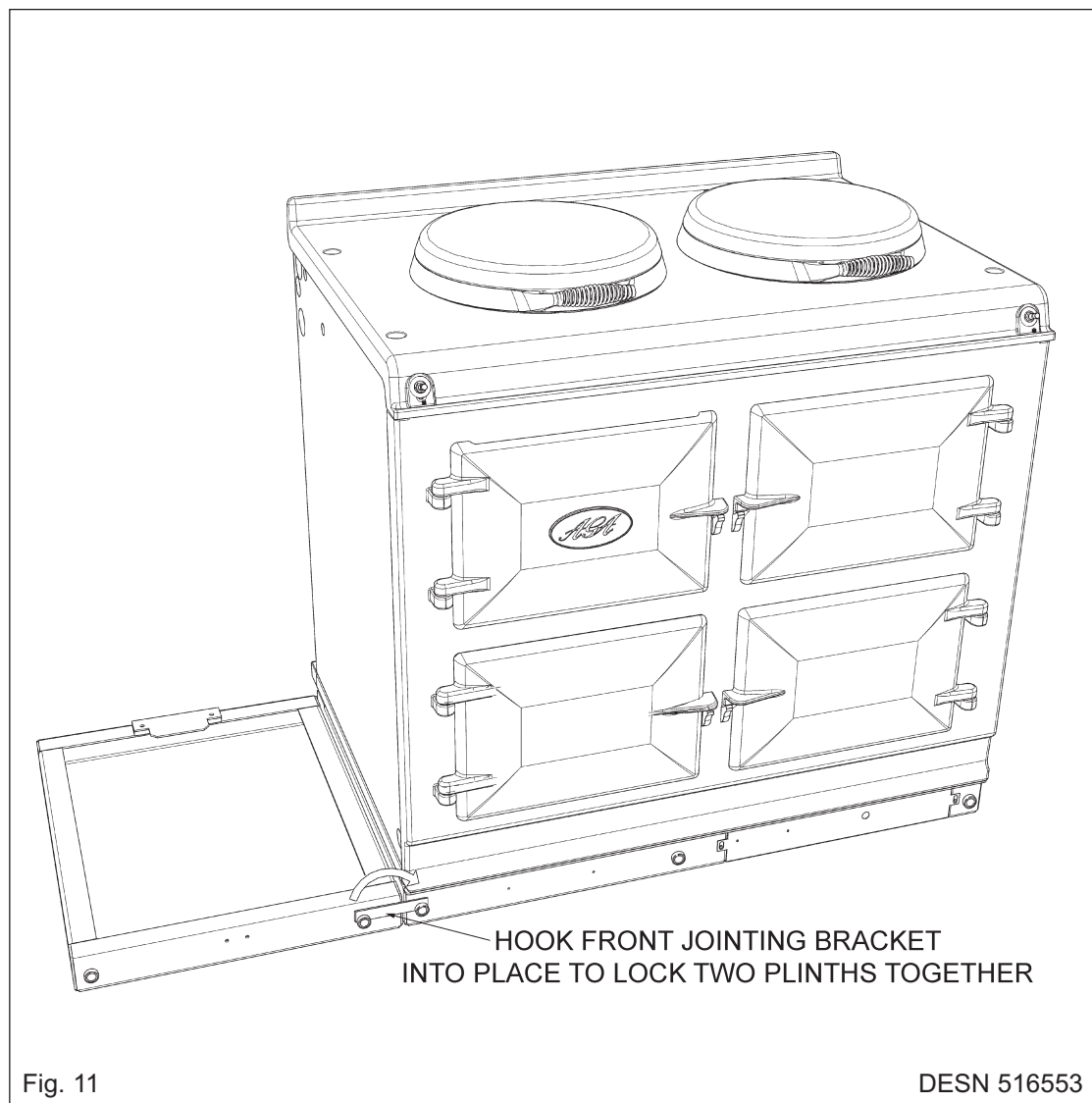

- Slide hotcupboard onto plinth until rear tongue bracket engages fully into rear of base slot, (See Fig. 12). Ensure the appliance is aligned squarely with the plinth then proceed to engage the front tongue bracket into the slot on the underside of the base plate. Once satisfied that the front tongue bracket is engaged fully lock it into place by tightening the two M6 screws fully. Ensure that the electrical cable does not come into contact with oven vent pipe from the AGA DC3.

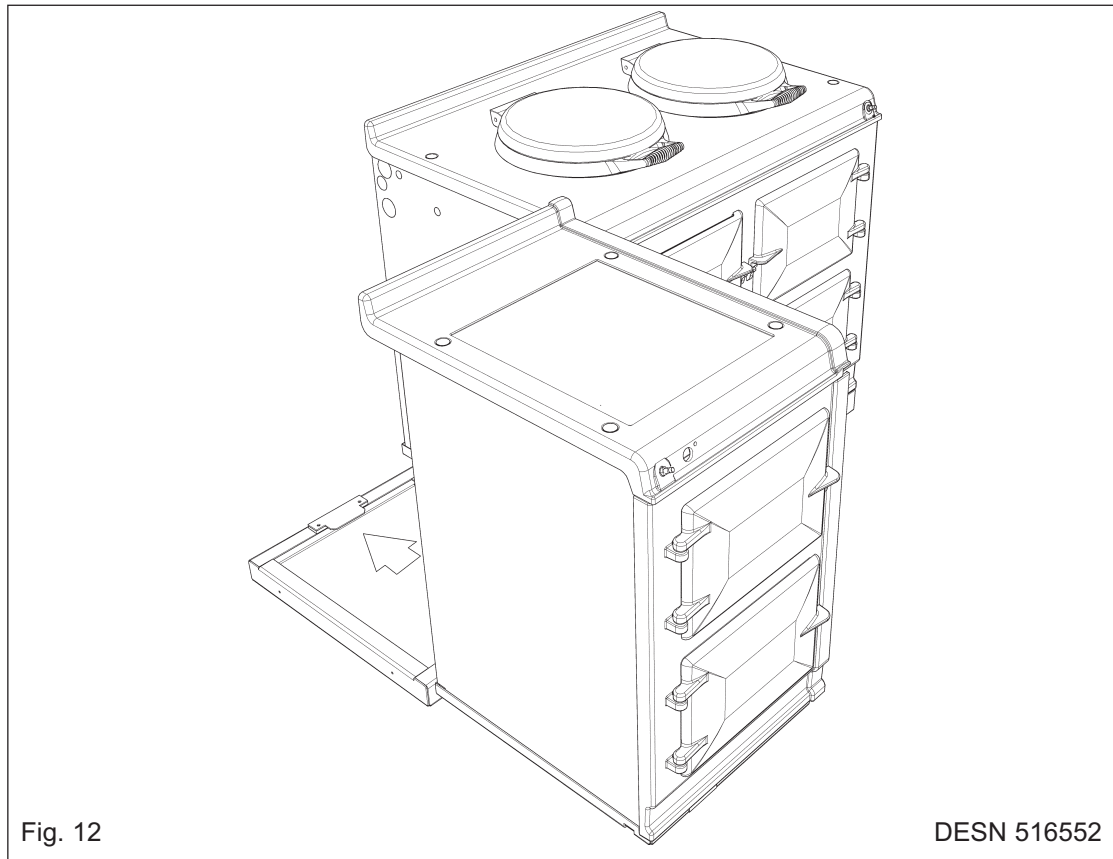

- The hotcupboard top plate is set  $\frac{1}{4}$ " (5mm) higher than the AGA Dual Control top plate. This is to prevent damage to the enamel during installation. Lower the top plate using the adjusters (See Figs. 13 & 14).

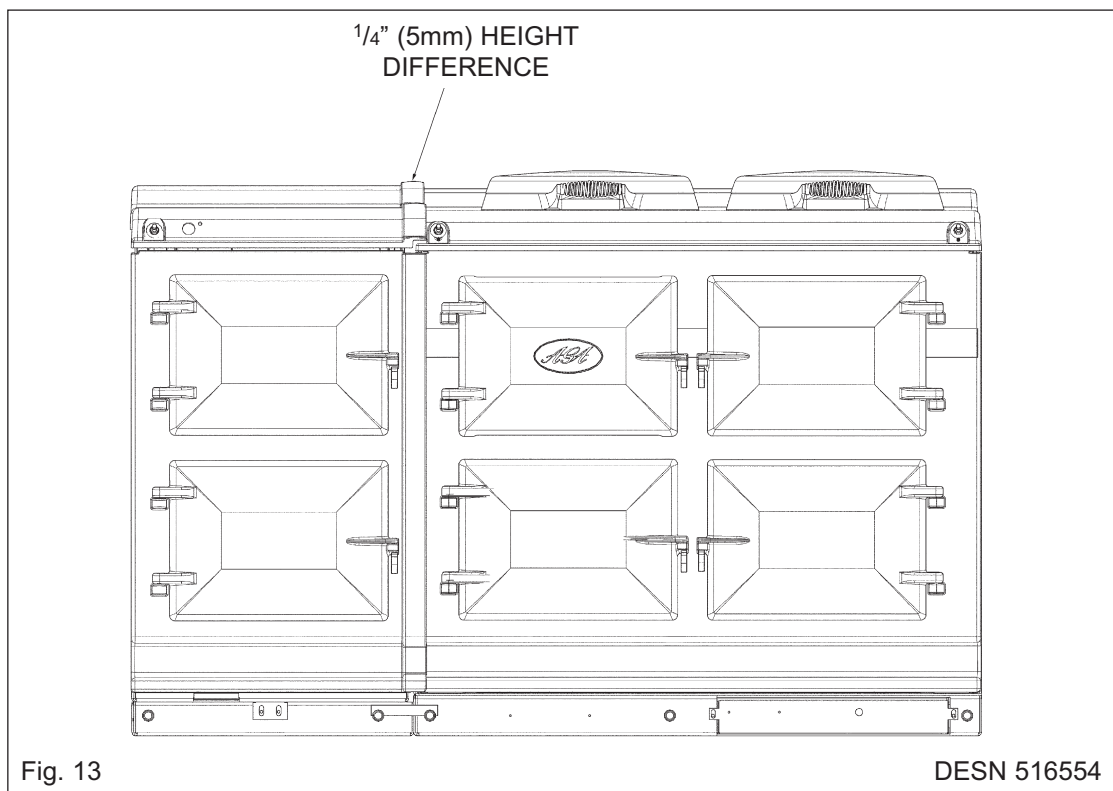



- Using the stay rod nut adjusting tool, carefully lower the top plate adjusting nuts until the top plate sits at the required height, making sure that the top sits level and matches the height of the AGA DC3. (See Fig. 14).

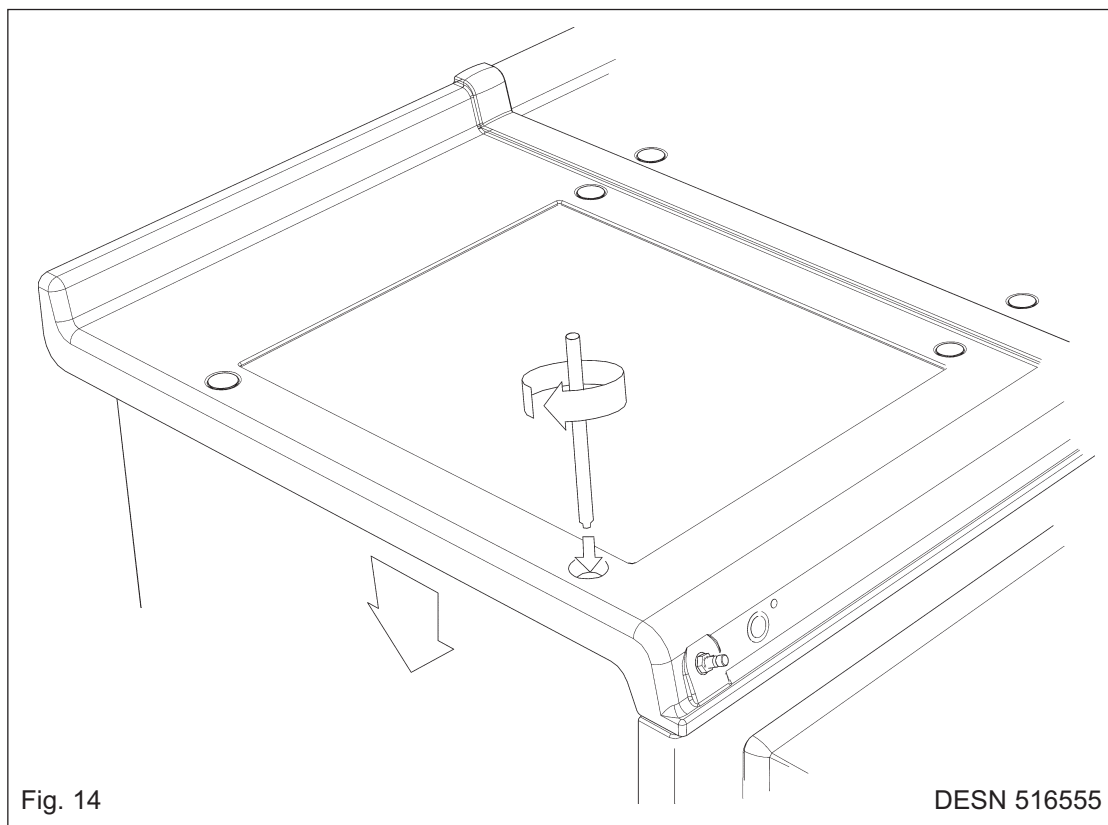

- Fit the handrail bracket over the fixing stud located on the top plate. Lock into position by tightening the grub screw nearest the appliance. (See Fig. 15).

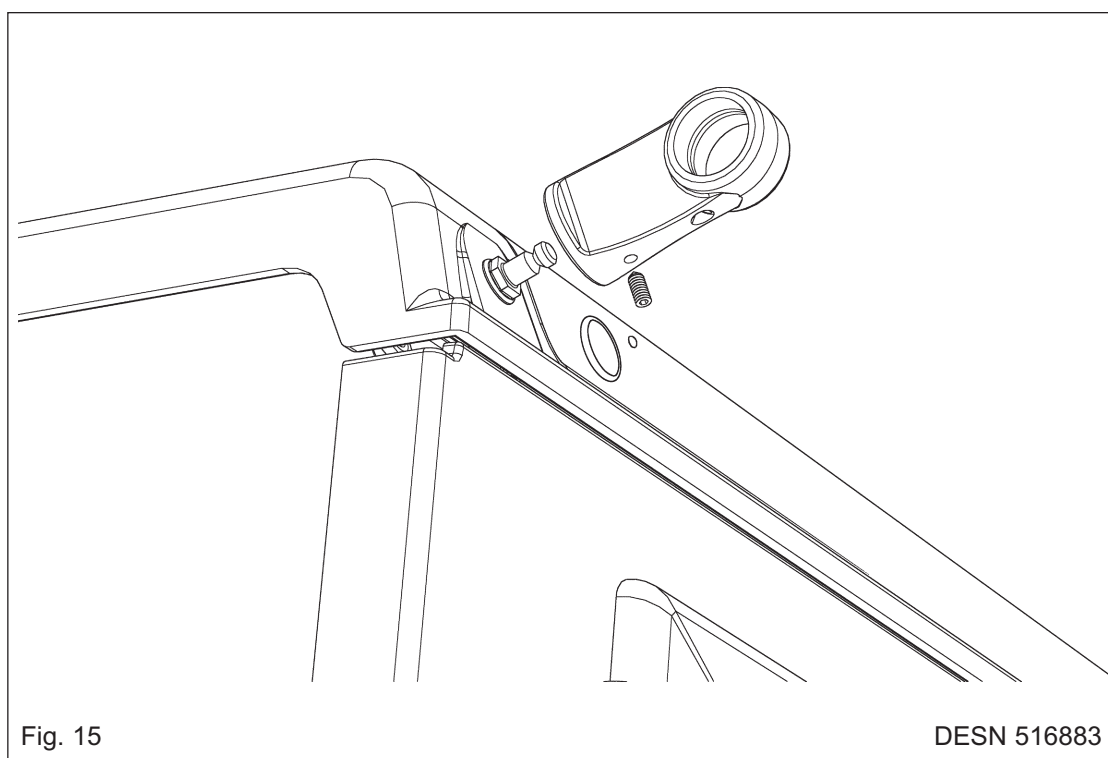

10. Next the handrail, endcaps and handrail require assembly.

Slide the handrail through the handrail brackets.

#### AGA DC3 HANDRAIL CONNECTION

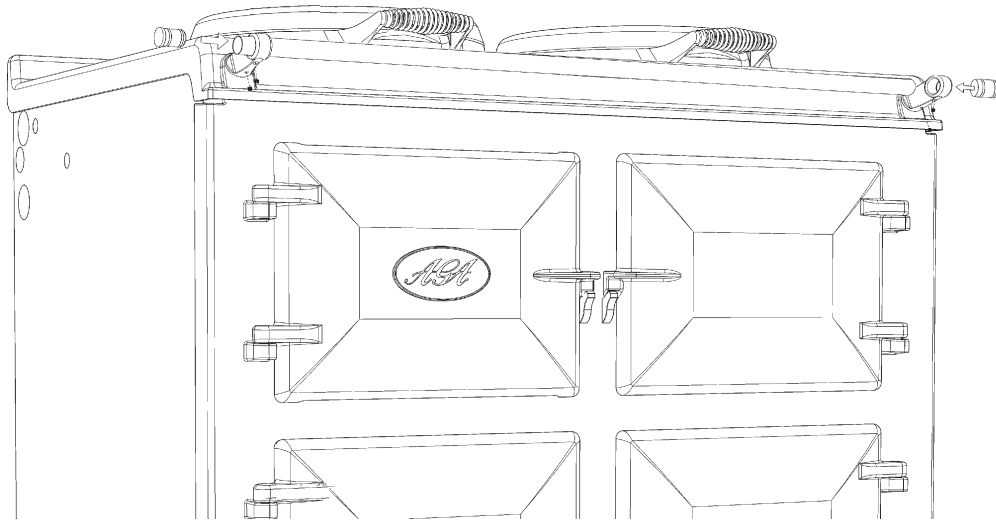

Fig. 16

DESN 516880

11. On 5 oven ranges, fit allthread stud into the insert located in the one end of the handrail, then feed the handrail through the bracket (ensuring that the allthread stud is protruding from the right hand side of the hotcupboard handrail) and screw the handrails together. (See Fig. 17).

#### AGA DC5 HANDRAIL CONNECTION

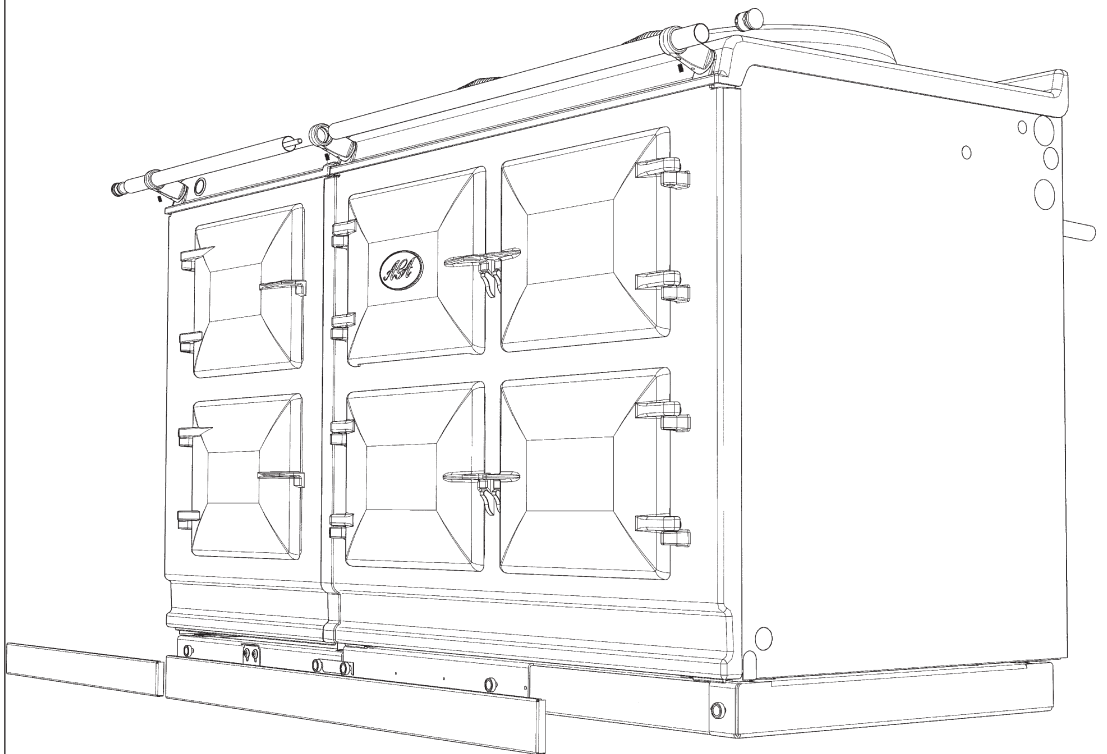

Fig. 17

DESN 516879

12. Once the handrail assembly is located squarely, lock the handrail in position by winding in the grub screws on the underside of each handrail bracket.
13. Once the handrails are locked in position, fit the handrail endcaps. The endcaps should be carefully pushed into place until they sit flush with the outside face of each bracket (a light smear of lubricant such as, washing up liquid on the end cap 'O' rings may ease fitment).
14. Finally, fit the plinth fascia to the magnets on the front of the plinth, making sure that on 5 oven ranges the right hand side of the module plinth fascia sits against the left hand side of the AGA Dual Control plinth fascia leaving no gap between. Make sure that the plinth fascias are centrally located and do not overhang either range. (See Fig. 17)

Commission the AGA Dual Control, as stated in the relevant Installation Instructions and carry out functional test on each of the features of the AGA Dual Control.

# WIRING DIAGRAM - AGA DC3

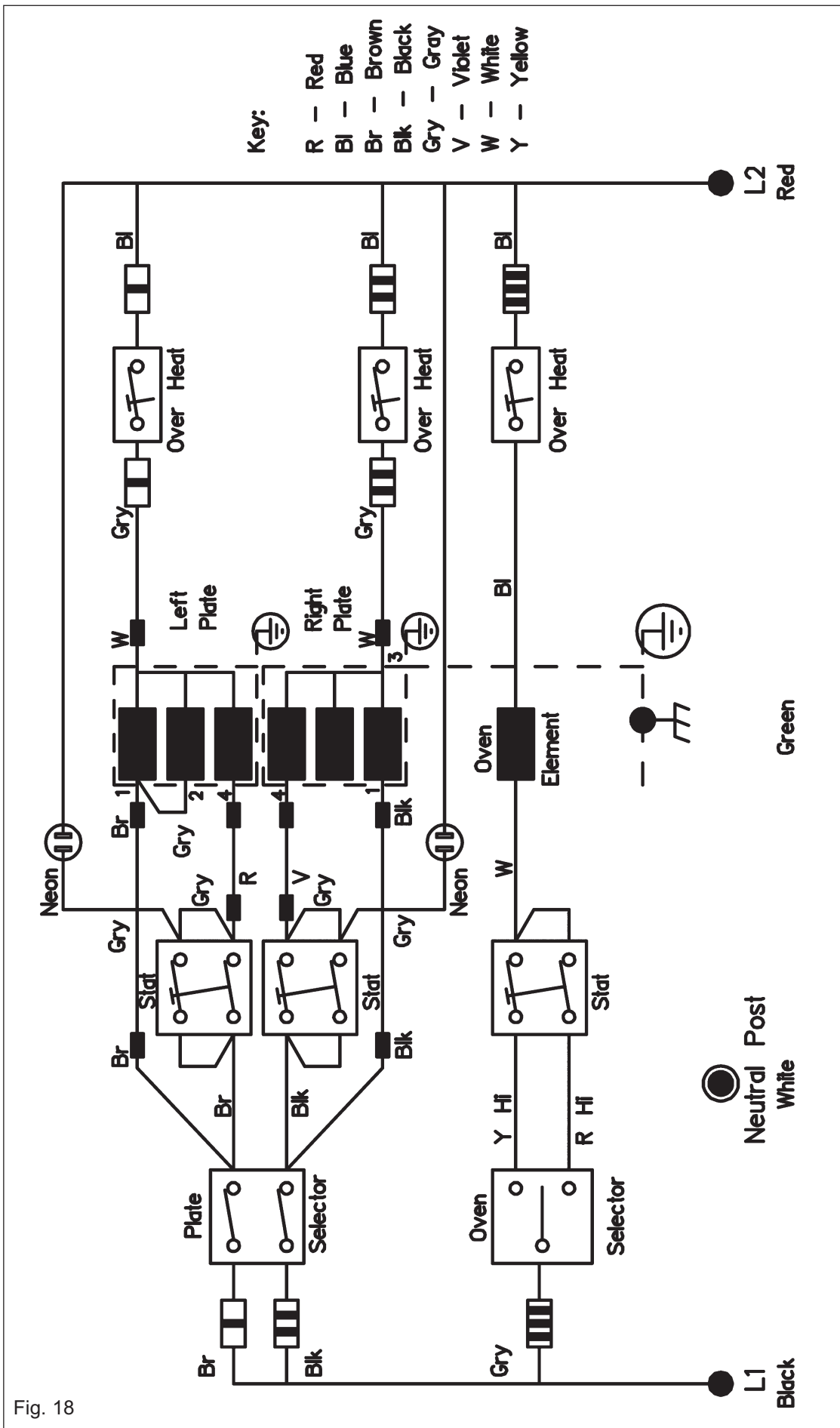

Fig. 18

## WIRING DIAGRAM - AGA DC5 (HOTCUPBOARD OPTION)

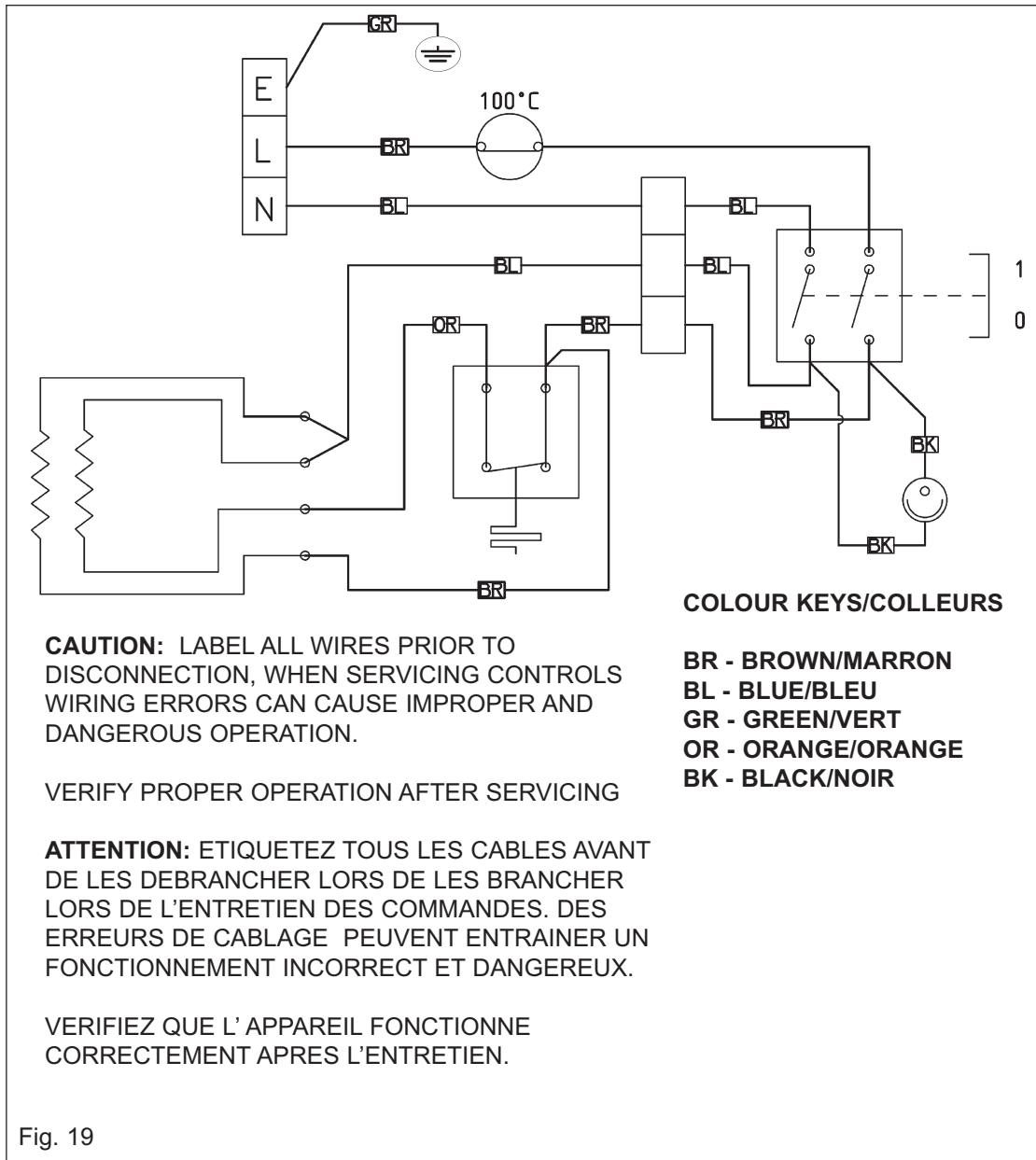

Fig. 19

## INSTRUCTIONS

Hand the Users Guide to the user for retention and instruct in the safe operation of the range.

Advise the user that, for continued efficient and safe operation of the range, servicing is carried out at intervals recommended by the AGA distributor.

When replacing a part on this range, use only replacement parts that you can be assured conform to the safety and performance specification that we require. Do not use reconditioned or copy parts that have not been clearly authorised by AGA.



**For further advice or information contact  
your local AGA Specialist**

With AGA Marvel's policy of continuous product improvement, the Company reserves the right to change specifications and make modifications to the appliance described and illustrated at any time



Supplied by

AGA Marvel  
1260 E. Van Deirse St.  
Greenville, MI, 48838

Business (616) 754-5601  
Fax (616) 754-9690  
Toll Free Telephone 800-223-3900

[www.agamarvel.com](http://www.agamarvel.com)