



# THROUGH THE WALL ROOM AIR CONDITIONER WITH OPTIONAL ELECTRIC HEAT INSTALLATION INSTRUCTIONS



**RECOGNIZE THIS SYMBOL AS A SAFETY PRECAUTION.**

## ATTENTION INSTALLING PERSONNEL

As a professional installer you have an obligation to know the product better than the customer. This includes all safety precautions and related items.

Prior to actual installation, thoroughly familiarize yourself with this Instruction Manual. Pay special attention to all safety warnings. Often during installation or repair it is possible to place yourself in a position which is more hazardous than when the unit is in operation.

Remember, it is **your** responsibility to install the product safely and to know it well enough to be able to instruct a customer in its safe use.

Safety is a matter of common sense...a matter of thinking before acting. Most dealers have a list of specific good safety practices...follow them.

The precautions listed in this Installation Manual are intended as supplemental to existing practices. However, if there is a direct conflict between existing practices and the content of this manual, the precautions listed here take precedence.



is a registered trademark of Maytag Corporation or its related companies and is used under license to Goodman Company, L.P., Houston, TX. All rights reserved.

[www.amana-ptac.com](http://www.amana-ptac.com)

© 2010 Goodman Company, L.P.



# TABLE OF CONTENTS

- Important Note to Owner ..... 2
- Important Note to Servicer ..... 2
- Operating Instructions ..... 2
- Unit Features ..... 2
- Installation Instructions ..... 3
- Wiring ..... 6
- Air Conditioner Features ..... 7
- Additional Information ..... 11
- Normal Operating Sounds and Conditions ..... 11
- Obtaining Service ..... 11
- Consumer Warranty ..... 12
- Commercial Warranty ..... 13

### IMPORTANT NOTE TO THE HOMEOWNER

This manual is to be used by qualified, professionally trained HVAC technicians only. Goodman does not assume any responsibility for property damage or personal injury for improper service procedures or services performed by an unqualified person.

### IMPORTANT NOTE TO THE SERVICER

Read this manual and familiarize yourself with the specific items which must be adhered to before attempting to service this unit. The precautions listed in this Installation Manual are intended as supplemental to existing practices. However, if there is a direct conflict between existing practices and the content of this manual, the precautions listed here take precedence.

**WARNING**

---

**HIGH VOLTAGE**  
**DISCONNECT ALL POWER BEFORE SERVICING OR INSTALLING THIS UNIT. MULTIPLE POWER SOURCES MAY BE PRESENT. FAILURE TO DO SO MAY CAUSE PROPERTY DAMAGE, PERSONAL INJURY OR DEATH.**



**WARNING**

---

**GOODMAN WILL NOT BE RESPONSIBLE FOR ANY INJURY OR PROPERTY DAMAGE ARISING FROM IMPROPER SERVICE OR SERVICE PROCEDURES. IF YOU INSTALL OR PERFORM SERVICE ON THIS UNIT, YOU ASSUME RESPONSIBILITY FOR ANY PERSONAL INJURY OR PROPERTY DAMAGE WHICH MAY RESULT. MANY JURISDICTIONS REQUIRE A LICENSE TO INSTALL OR SERVICE HEATING AND AIR CONDITIONING EQUIPMENT.**

## OPERATING INSTRUCTIONS

Check the data specification plate and ensure the proper voltage and current rating is available for the type power plug on the unit. DO NOT REMOVE THE GROUNDING PRONG FROM THE POWER CORD. Note the types of acceptable plugs on the following figure.

Refer to the data serial plate for electrical requirements.

**CAUTION**

---

**TO AVOID PROPERTY DAMAGE, PERSONAL INJURY OR DEATH DUE TO ELECTRICAL SHOCK, DO NOT USE AN EXTENSION CORD WITH THIS UNIT.**

## UNIT FEATURES

This unit has many features which are different than those found on conventional units. The servicer must be familiar with these features in order to properly service the unit.

Check the data specification plate and ensure the proper voltage and current rating is available for the type power plug on the unit. DO NOT REMOVE THE GROUNDING PRONG FROM THE POWER CORD. Note the types of acceptable plugs in Figure 1.

Refer to the data serial plate for electrical requirements.

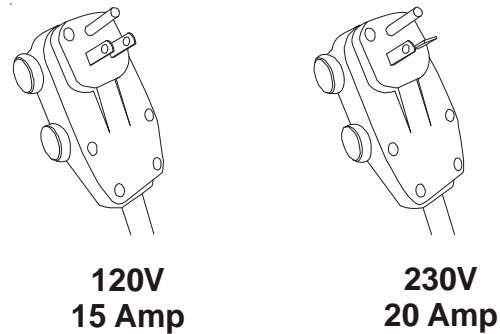
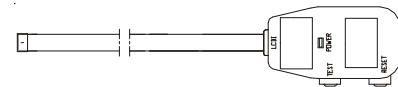

Figure 1

- **LCDI or AFCI Power Cords** - Underwriters Laboratories and the National Electric Code (NEC) now require power cords that sense current leakage and can open the electrical circuit to the unit on units rated at 250 volts or less. In the event that unit does not operate, check the reset button located on or near the head of the power cord as part of the normal troubleshooting procedure.



LCDI Power Cord

Figure 2

**WARNING**

---

**HIGH VOLTAGE**  
**DISCONNECT ALL POWER BEFORE SERVICING OR INSTALLING THIS UNIT. MULTIPLE POWER SOURCES MAY BE PRESENT. FAILURE TO DO SO MAY CAUSE PROPERTY DAMAGE, PERSONAL INJURY OR DEATH.**  
**TO PREVENT ELECTRICAL SHOCK, PROPERTY DAMAGE, PERSONAL INJURY OR DEATH, DO NOT REMOVE GROUNDING PRONG FROM PLUG. FOLLOW ALL OPERATING INSTRUCTIONS.**



### VOLTAGE MEASUREMENTS

Before connecting the unit, measure the supply voltage. Voltage must fall within the voltage utilization range given in the following table.

Operating Voltage		
Unit Voltage	Voltage Utilization Range	
Rating	Minimum	Maximum
230/280	187	253
115	103	126

## INSTALLATION INSTRUCTIONS

To ensure that the unit operates safely and efficiently, it must be installed, operated, and maintained according to these installation and operating instructions and all local codes and ordinances, or, in their absence, with the latest edition of the National Electrical Code. The proper installation of this unit is described in the following sections. Following the steps in the order presented should ensure proper installation.

### SLEEVE INSTALLATION

In order for condensate water to drain properly inside the unit, the sleeve must be installed properly:

- Level from right to left.
- A slight downward pitch from the indoor side to the outdoor side as shown in Figure 3.

Refer to the Installation Instructions supplied with the wall sleeve for a complete description of the installation procedure.

**NOTE:** Wall sleeve (PBWS01A ) is not shipped with chassis and must be purchased separately.

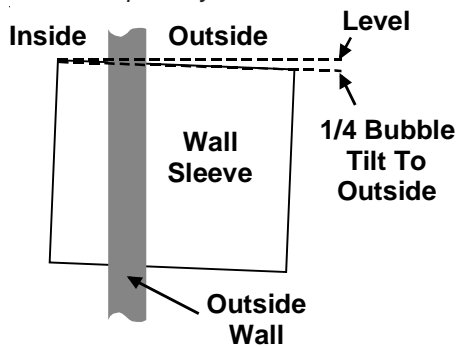

Figure 2

### REAR LOUVER PANEL

A TWKG rear louver panel kit is required for unit installation into an existing Amana® brand 26" wall sleeve. A TWEAK or TWFAK adapter kit is required for unit installation into an existing 27" wall sleeve. The rear louver panel directs air flow for proper unit operation and protects the outdoor coil. The panel must be installed before installing the chassis. These kits are not supplied with the unit. Refer to the Installation Instructions supplied with the rear louver panel kit for a complete description of the installation procedure.

### CHASSIS INSTALLATION

1. Remove front grille. See Figure A.

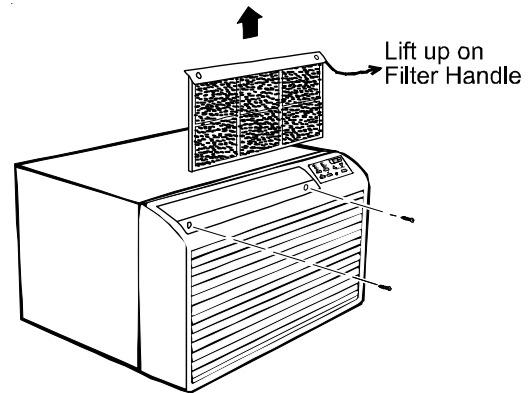
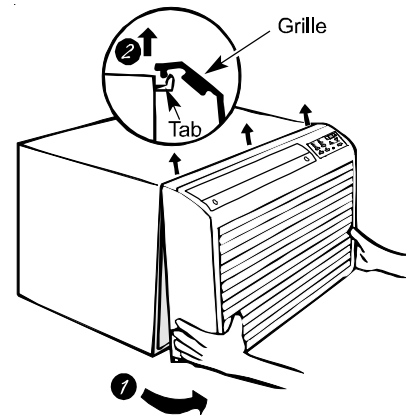

Figure A

The front grille can be removed for more thorough cleaning or to make the model and serial numbers accessible. To remove, pull the filter out and remove the two grille screws.



Pull the grille out from the bottom and lift up from the tabs on the top of the case.

2. Remove the grounding screw and wire next to the grounding symbol on right side of chassis control panel (Figure 3). Attach other end of ground wire to the hole in the bottom right side of the sleeve with #8 x 3/8" blunt point sheet metal screw. The hole on the sleeve is indicated by grounding symbol on the sleeve. Slide chassis part of the way into the sleeve and reattach the ground wire back to the hole on the right side on the control panel area next to the grounding symbol.

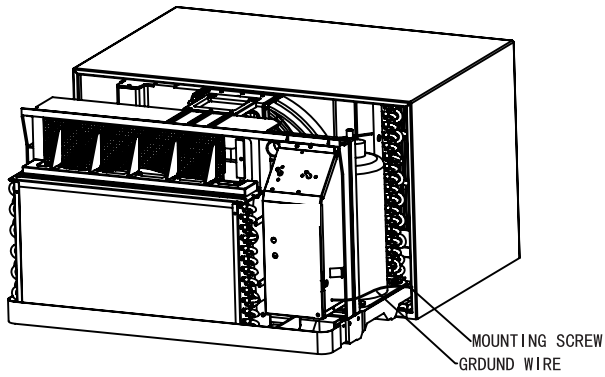

**Figure 3**

3. Remove shipping pads inside air conditioner next to compressor. (See Figure B.)

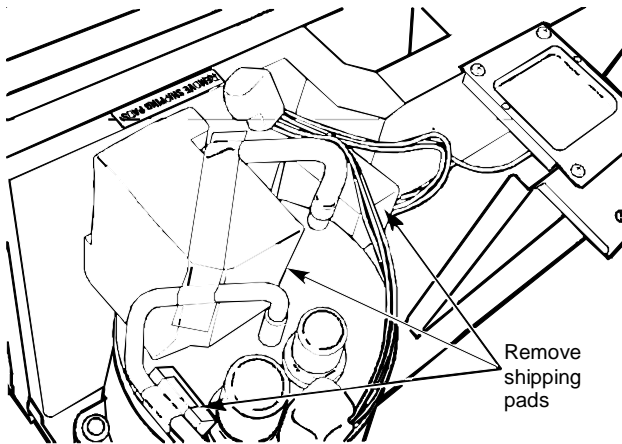

**Figure B**

4. Carefully slide the chassis into the sleeve. Ensure that the ground wire is not pinched or in the path of the condenser fan.
5. Loosen locking plate screw and rotate tab with tab behind wall case flange (See Figure C) then tighten locking plate screw.

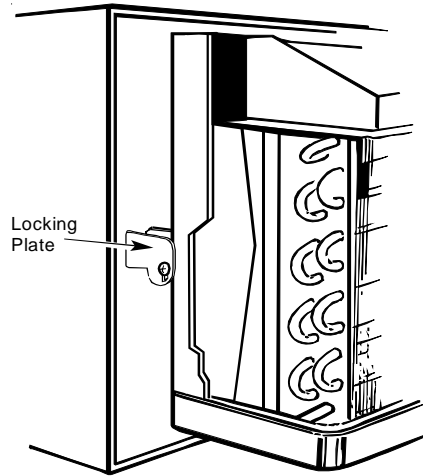

**Figure C**

6. If outlet is on the left side of the unit, route power cord as shown in Figure D.

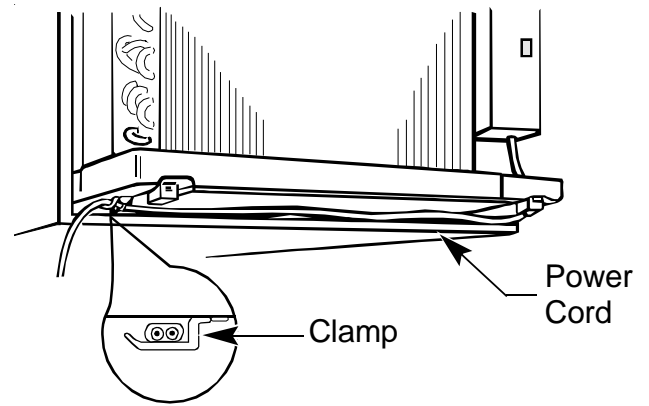

**Figure D**

To replace front grille:

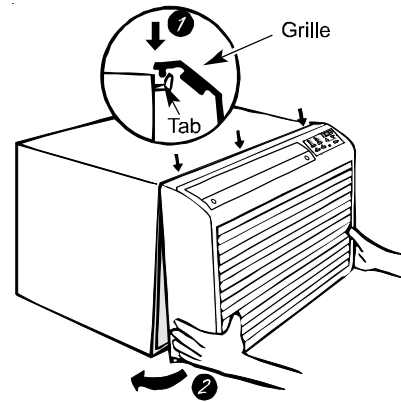

Hook the tabs on the front grille even with the tabs on the case and snap into place. Replace the screws and filter. Refer to Page 3, Figure A.

### VENT CONTROL AND AIR DIRECTION (See Figure E)

The vent control is located behind the front grille on the right side of the air discharge area. When set at **CLOSE** only the air inside the room will be circulated and conditioned. When set at **OPEN**, some inside air is exhausted outside.

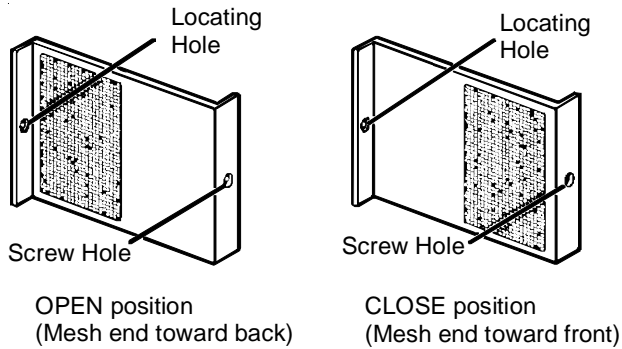

**Figure E**

To open or close the vent:

1. Remove the front grille.
2. Remove the vent card screw.
3. Remove the vent card, turn it over and replace it by locating rear hole in card over locating pin inside air discharge and reattaching screw at front.

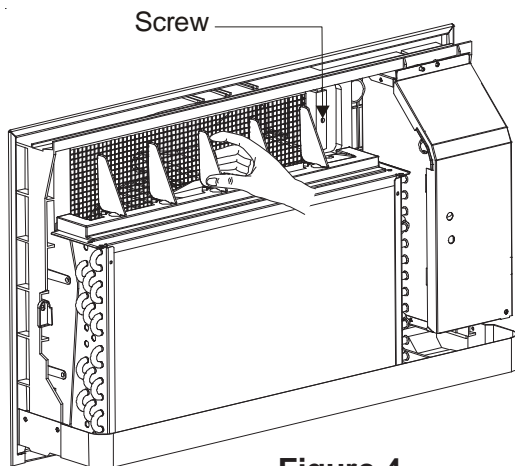

**Figure 4**

### AIR DIRECTION:

Horizontal louvers on the front grille let you control the air direction up and down.

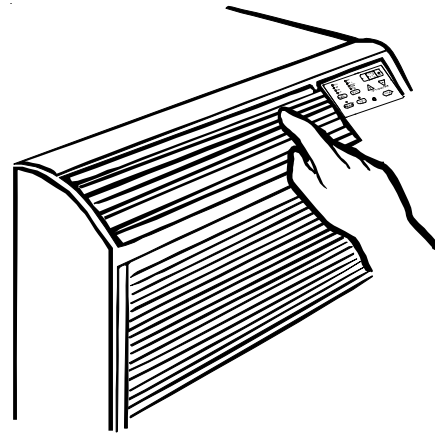

Remove the front grille to adjust the vertical louvers side-to-side to direct the air left or right.

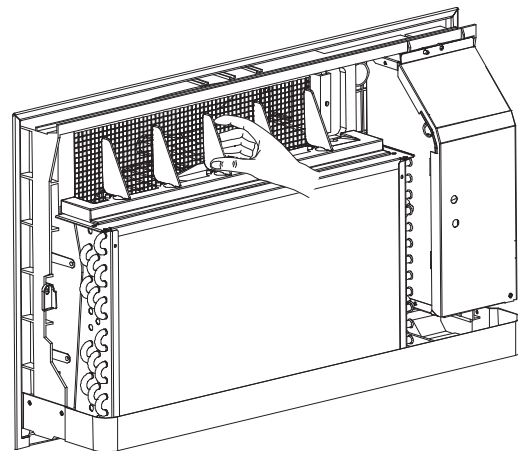

**Figure 5**

### IMPORTANT NOTES:

1. The unit is equipped with a rubber-grommet-mounted compressor. These grommets are factory set and require no adjustment.
2. Obstruction to air flow must be checked and removed. Check the indoor and outdoor grilles for obstructions. The unit must be located where curtains, furniture, trees, or other objects do not block air flow to and from the unit. If air is obstructed and/or deflected back into the unit, the air conditioner's compressor may cycle on and off rapidly. This could cause damage to the compressor.

## WIRING

Before wiring the unit, please review the following warnings and cautions.

### WARNING

TO AVOID PROPERTY DAMAGE, PERSONAL INJURY OR DEATH DUE TO ELECTRICAL SHOCK, DO NOT USE AN EXTENSION CORD WITH THIS UNIT.

### WARNING

TO AVOID THE RISK OF PROPERTY DAMAGE, PERSONAL INJURY OR FIRE, USE ONLY COPPER CONDUCTORS.

### WARNING

TO AVOID THE RISK OF PERSONAL INJURY, WIRING TO THE UNIT MUST BE PROPERLY POLARIZED AND GROUNDED.

### WARNING

TO AVOID THE RISK OF PROPERTY DAMAGE, PERSONAL INJURY OR FIRE, DO NOT INSTALL WITH POWER CORD STRETCHED OR UNDER A STRAIN AS THIS MAY CREATE A LOOSE PLUG/RECEPTACLE CONNECTION.

### WARNING

THIS AIR CONDITIONER IS NOT MEANT TO PROVIDE UNATTENDED COOLING OR LIFE SUPPORT FOR PERSONS OR ANIMALS WHO ARE UNABLE TO REACT TO THE FAILURE OF THIS PRODUCT.

THE FAILURE OF AN UNATTENDED AIR CONDITIONER MAY RESULT IN EXTREME HEAT IN THE CONDITIONED SPACE CAUSING OVERHEATING OR DEATH OF PERSONS OR ANIMALS. TAKE PROPER PRECAUTIONS TO AVOID UNATTENDED OPERATION.

### WARNING

#### HIGH VOLTAGE

DISCONNECT ALL POWER BEFORE SERVICING OR INSTALLING THIS UNIT. MULTIPLE POWER SOURCES MAY BE PRESENT. FAILURE TO DO SO MAY CAUSE PROPERTY DAMAGE, PERSONAL INJURY OR DEATH.

DO NOT SERVICE THIS UNIT WITHOUT FIRST OPENING ALL DISCONNECTS AND/OR REMOVING THE UNIT CORD SET PLUG FROM THE WALL OUTLET.



# AIR CONDITIONER FEATURES

## ELECTRONIC CONTROL OPERATING INSTRUCTIONS

Before you begin, thoroughly familiarize yourself with all of the functions of the control panel and remote as shown below and follow the instructions. *The unit can be controlled by the touchpad alone or with the remote control.*

### COOLING ONLY UNIT

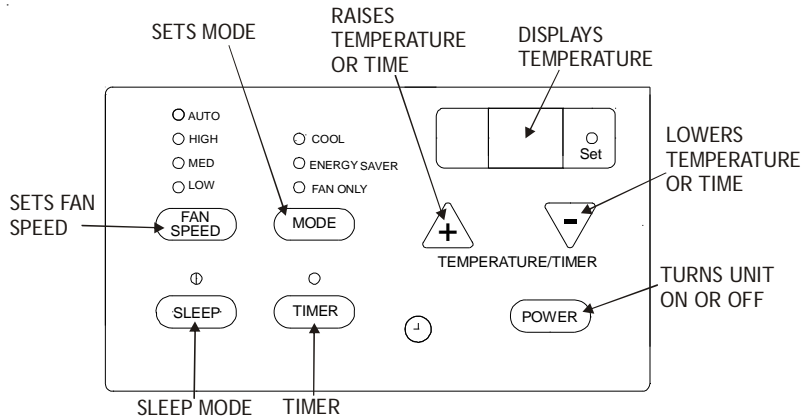

### HEAT/COOL UNIT

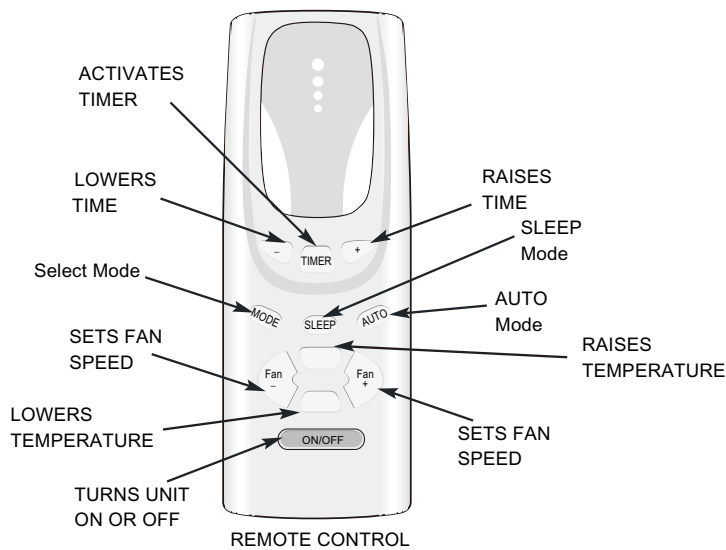
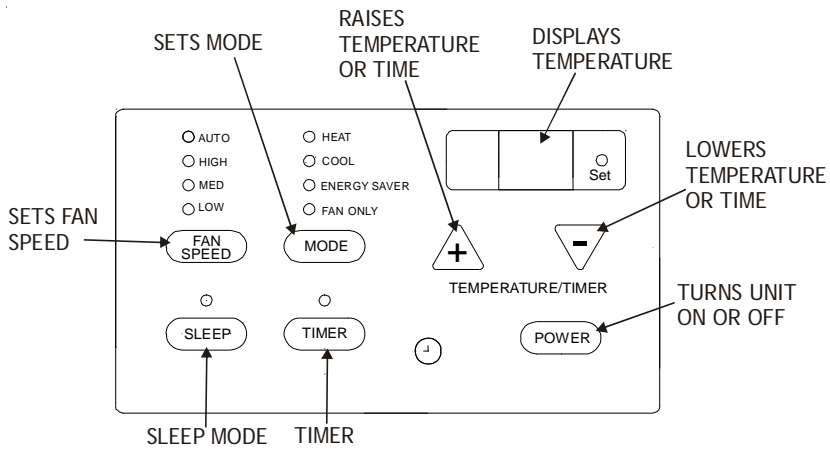

**NOTE:**

The remote control will work normally after a 5 second reset.

BATTERY SIZE: AAA

 <b>WARNING</b>
<b>DO NOT MIX OLD AND NEW BATTERIES. DO NOT MIX ALKALINE, STANDARD (ZINC-CARBON) OR RECHARGEABLE (NICKEL-CADMIUM) BATTERIES.</b>

# AIR CONDITIONER FEATURES

## TO TURN UNIT ON:

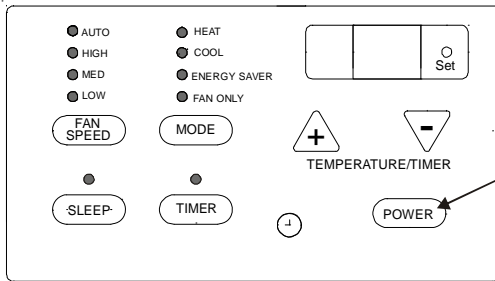

PRESS ON/OFF BUTTON

## YOU WILL SEE:

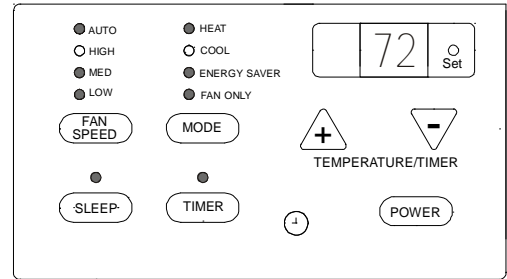

## TO CHANGE TEMPERATURE SETTING:

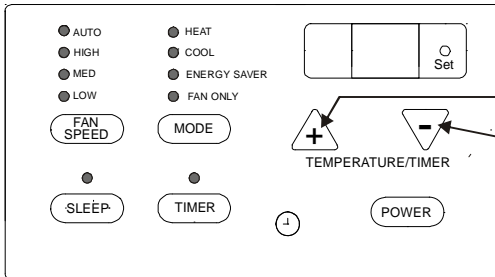

PRESS TO RAISE  
PRESS TO LOWER

## YOU WILL SEE:

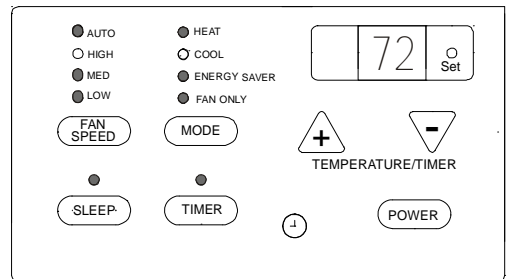

### NOTE:

Tap or hold either up (▲) or down (▼) button until the desired temperature is seen on the display. This temperature will be automatically maintained anywhere between 60°F (16°C) and 86°F (30°C) for both cooling and heating modes.

If you want the display to read the actual room temperature, select the **FAN ONLY MODE**.

## TO CHANGE FAN SPEEDS:

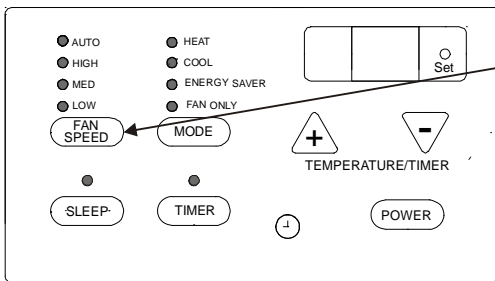

PRESS FAN SPEED BUTTON  
SELECT SPEED

## LIGHT ON

## YOU WILL SEE THE SPEED CHOSEN:

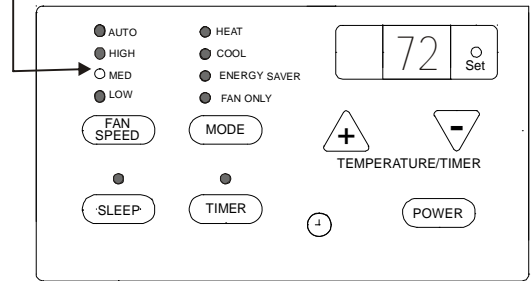

## TO CHANGE AUTO FEATURE:

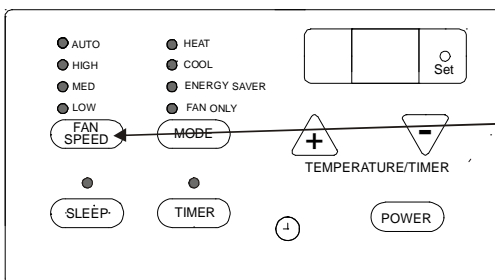

PRESS FAN SPEED BUTTON  
SELECT AUTO FAN

## LIGHT ON

## YOU WILL SEE:

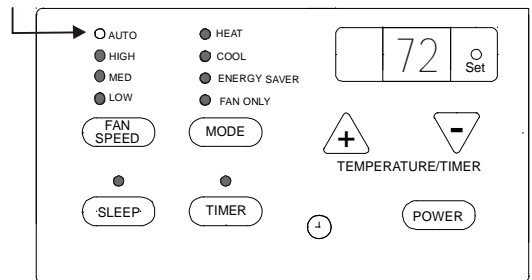

### NOTE:

The fan speed will automatically set to the speed needed to provide optimum comfort setting with the set temperature. If the room needs more cooling, the fan speed will automatically increase. If the room needs less cooling, the fan speed will automatically decrease. *Auto fan speed cannot be used when in the **FAN ONLY** mode.*



# AIR CONDITIONER FEATURES

## TO OPERATE ON FAN ONLY:

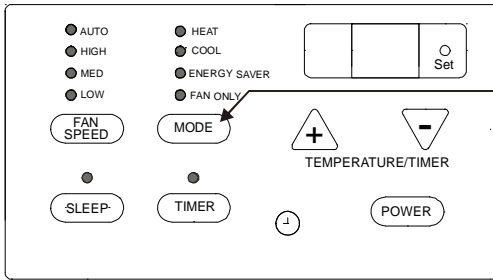

PRESS  
MODE  
BUTTON  
  
CHOOSE  
FAN ONLY

## YOU WILL SEE:

LIGHT ON

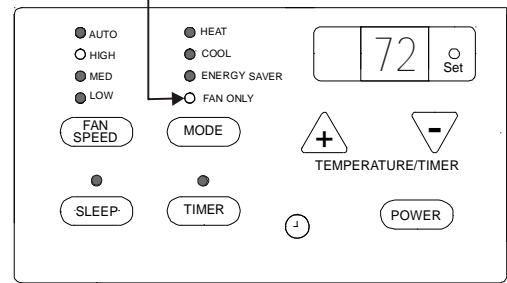

Note: Use this function only when cooling is not desired, such as for room air circulation. You can choose any fan speed you prefer, except AUTO FAN. During this function, the display will show the actual current temperature, not the set temperature as in the cooling mode.

## TO USE THE ENERGY SAVER FEATURE:

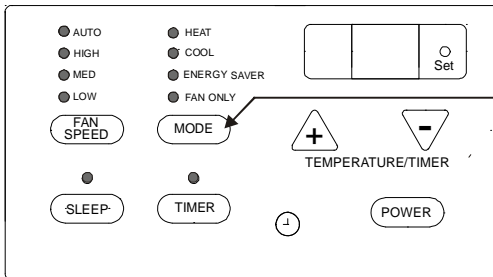

PRESS  
MODE  
BUTTON  
  
CHOOSE  
ENERGY SAVER

## YOU WILL SEE:

LIGHT ON

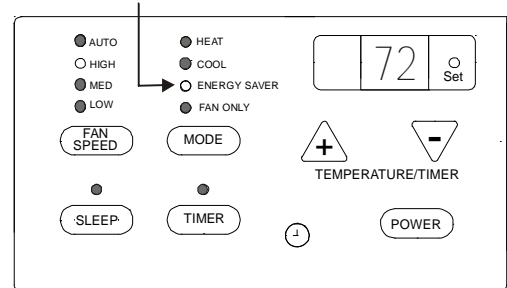

Note: In this mode, the fan will continue to run for 1 (one) minute after the compressor or electric heat strip shuts off. **This results in wider variations of room temperature and is normally used when the room is unoccupied.**

## TIMER-DELAY START/STOP FEATURE:

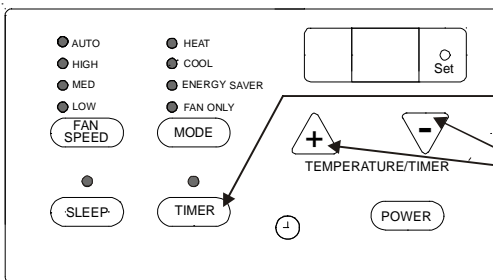

PRESS  
TIMER BUTTON  
  
THEN PRESS  
TEMP/TIMER  
BUTTON

## YOU WILL SEE THE TIME CHOSEN:

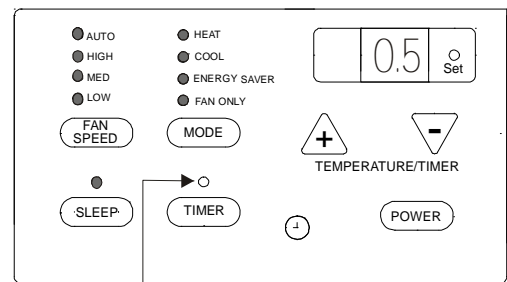

LIGHT ON

### NOTES:

1. For **DELAY STOP**, the unit must be in the **ON** position.
2. For **DELAY START**, the unit must be in the **OFF** position.

To adjust the timer setting, tap or hold the **UP** (▲) arrow or **DOWN** (▼) arrow to change the delay time by 1/2 hour (0.5) increments up to 10 hours; then 1 hour increments up to 24 hours. The control will count down the time remaining until start or stop (8, 7.5, 7, etc.).

After setting the Timer, the unit will enter into Timer mode within 5 seconds. The Timer light will then be on and the Set light will be off.

While in Timer mode, the Set temperature and fan speed will maintain previously set temperature and fan speed and the Temperature display will show the set temperature. (There will be no display if the power is turned off.) By pressing the Timer once,

the LED displays the remaining portion of the set time. (The LED will return to set temperature within 5 seconds.) When in Fan Only mode, the LED will only display the room temperature; it will not display set temperature.

Turning the unit "ON" or "OFF" at any time will cancel the **DELAY START/STOP** function. The **DELAY START/STOP** feature will work until the unit starts or stops. Once this has happened, the above steps must be repeated again.

**NOTE:** Factory default setting is for °F. To convert to °C, press the **INCREASE ▲ / DECREASE ▼** buttons simultaneously for approximately 5 seconds. To return to °F, repeat the procedure.

# AIR CONDITIONER FEATURES

## HEATING FEATURE (on some models):

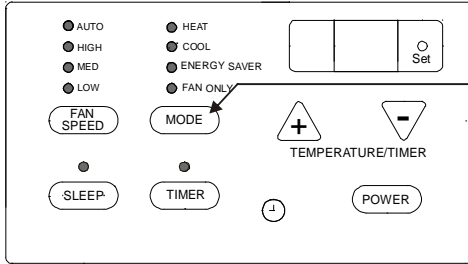

PRESS  
MODE  
BUTTON  
  
SELECT HEAT

## YOU WILL SEE:

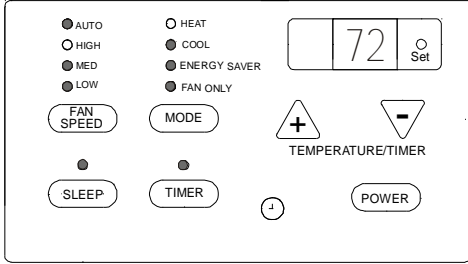

Note: This feature can be used with any combination of FAN Speeds, Timer or Sleep Modes. When in the “heat” Mode, the fan will run continuously while heat is needed. The temperature will automatically be maintained anywhere between 61°F (16°C) and 86°F (30°C).

## SLEEP FEATURE:

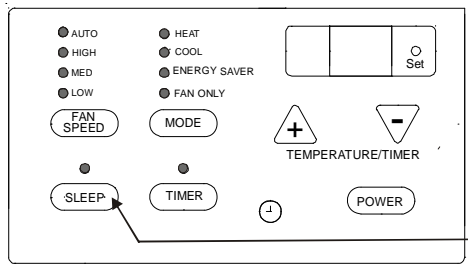

PRESS  
MODE  
BUTTON  
  
SELECT SLEEP

## YOU WILL SEE:

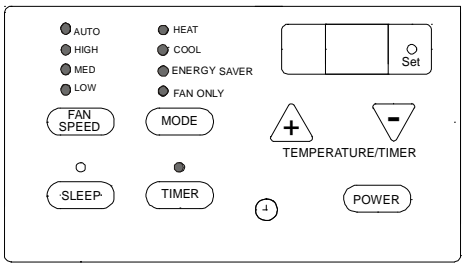

Note: After pressing this button, SLEEP ON and SLEEP OFF can be selected. After powered on, SLEEP OFF is defaulted. After the unit is turned off, the SLEEP function is cancelled. If SLEEP mode is set while the unit is in COOL or ENERGY SAVER modes, the SET TEMP. would increase 1.8°F (1°C) in 1 hour and 3.6°F (2°C) in 2 hours. If SLEEP mode is set while unit is in HEAT mode, the SET TEMP. would decrease 1.8°F (1°C) in 1 hour and 3.6°F (2°C) in 2 hours. *When unit is in FAN ONLY and AUTO modes, this function is not available.*

## TO TURN UNIT OFF:

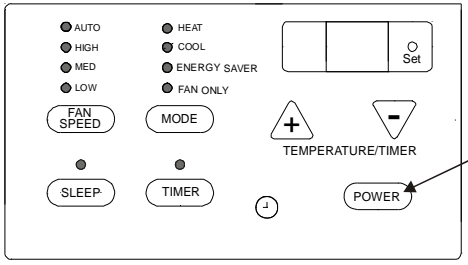

PRESS  
ON/OFF  
BUTTON

## YOU WILL SEE:

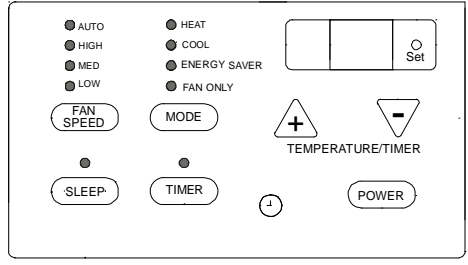

## FAULT CODES

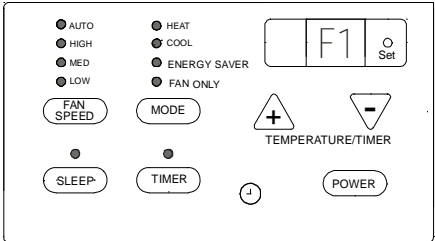

If the display reads “F1”, a sensor has failed.

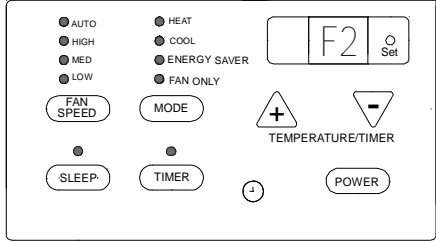

If the display reads “F2”, a sensor has failed.

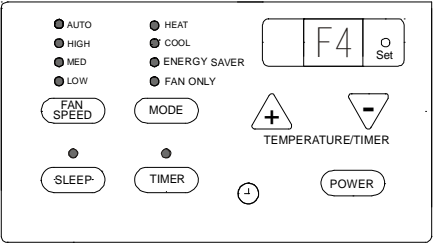

If the display reads “F4”, a sensor has failed.

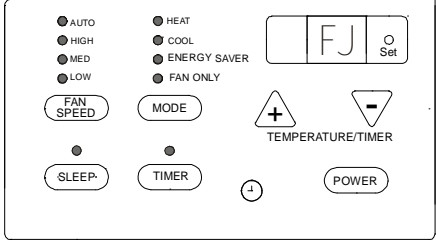

If the display reads “FJ”, a sensor has failed.

## ADDITIONAL INFORMATION

- The remote control will operate all the control panel features. Instructions will be the same.
- **The “COOL” circuit has an automatic 3 minute time delayed start if the unit is turned off and on quickly. This prevents overheating of the compressor and possible circuit breaker tripping.**

NOTE: The fan will continue to run during this time.

- The control will maintain any set temperature between 60°F and 90°F (cooling), 55°F and 80°F (heating).
- The control is capable of displaying temperature in degrees (Fahrenheit) or degrees (Celsius). To convert from one to the other, press and hold the UP and DOWN Temperature Selection Pads at the same time for 3 seconds.

### COMPRESSOR

The compressor is hermetically sealed, permanently lubricated and requires no additional oiling.

### FRONT PANEL AND GRILLE

The front panel and grille can be cleaned with a mild soap or detergent. Do not use hydrocarbon-based cleaners (e.g. acetone, benzene, naphtha, gasoline, etc.) to clean the front panel or grille. Use care when cleaning the control area. Do not use an excessively wet cleaning cloth.

### SCHEDULED MAINTENANCE

To achieve continuing top performance and high efficiency, a regular cleaning/inspection schedule must be established. Maintaining this schedule can be accomplished by either a local maintenance staff or an authorized servicer and must follow the instructions described in this manual.

- If the unit is operated in a dusty climate, dust may collect in the basepan and clog the condenser coil. It is advisable to remove the unit from the sleeve and thoroughly clean the basepan and condenser coil on a periodic basis.
- If the unit is installed ocean side or in a corrosive atmosphere, its life may be greatly reduced by the corrosive environment. Under these conditions, the unit should be removed from the sleeve and completely cleaned once a year. At that time any scratches or blisters on the painted surfaces should be sanded and repainted.

### OUTDOOR COIL CLEANING

The coils on the outdoor side of the air conditioner should be checked regularly. For cleaning outside coil, remove the 6 screws that mount the condenser coil top cover to condenser shroud.



## NORMAL OPERATING SOUNDS AND CONDITIONS

### POPPING OR GURGLING SOUNDS

This sound is the refrigerant traveling through the lines. This is a normal sound which may be heard for a few seconds after the unit shuts off.

### WATER TRICKLING SOUNDS

This sound is produced by the water as it is picked up and run over the coils. This procedure improves the efficiency of the unit and helps with water removal.

### WATER DRIPPING

Water will collect in the basepan during high humidity days.

### STARTING DELAY

You may notice a short delay in the startup if you try to restart the unit too soon after turning it off or if you adjust the thermostat right after the compressor has shut off. This delay protects the compressor.

## Obtaining Service

In the unlikely event this unit requires repair or servicing beyond what is covered in this manual, contact an authorized service organization.

To obtain an authorized servicer, contact your sales representative or agency.



## LIMITED WARRANTY CONSUMERS

### RAC WINDOW TYPE H & C (AE, AH, PBC, PBE, PBH)

This warranty is extended only to purchasers for personal, family or household use. A distinct warranty is extended to commercial customers.

Amana® brand RAC window-type heating or air conditioning units identified as AE, AH, PBC, PBE and PBH units are warranted by Goodman Company, L.P. to consumers against defects in materials and workmanship under normal use and maintenance, as provided below.

**FIRST-YEAR COVERAGE (ENTIRE UNIT):** We will repair or replace, free of charge (to include labor), any part of a unit that proves to be defective due to workmanship or materials within the first year after the date of purchase.

**SECOND THROUGH FIFTH YEARS SEALED SYSTEM COVERAGE:** During the 2<sup>nd</sup> through 5<sup>th</sup> years after the date of purchase, we will repair (to include labor) any refrigerant leaks caused by defects in workmanship or material of a unit, and will repair or replace (to include labor) any portion of the evaporator coil, condenser coil, compressor, reversing valves or connecting tubing that proves to be defective, in workmanship or materials.

If the date of purchase cannot be verified, the warranty period begins three months after the month of manufacture (indicated by the first four digits of the unit's serial number (yyymm)).

Any part replaced or leak repaired under this warranty is warranted only for the unexpired portion of the original warranty term.

The above remedies are our only responsibilities, and the consumer's only remedies, under this warranty. For warranty credit, any defective part must be returned to an Amana® brand heating and air conditioning products distributor by an authorized Amana® brand servicer; and all warranty service must be performed by an authorized Amana® brand servicer. To locate an authorized Amana® brand servicer, contact Goodman Company Consumer Affairs at the number or address found at the bottom of this certificate.

Goodman will not pay for electricity or fuel costs, or increases in electricity or fuel costs, for any reason, including additional or unusual use of supplemental electric heat. This warranty does not cover lodging.

Model # & Serial # \_\_\_\_\_

Date of Purchase \_\_\_\_\_



is a registered trademark of Maytag Corporation or its related companies and is used under license to Goodman Company, L.P., Houston, TX. All rights reserved.

For service, contact an Authorized Amana® Brand Servicer.

For answers to questions regarding the above or to locate an authorized servicer, contact

**Goodman Consumer Affairs • 7401 Security Way • Houston, Texas 77040**

Part No. PW-342B  
5/2010

1-877-254-4729 inside U.S.A. • 1-713-861-2500 outside U.S.A.

©2010 Goodman Company, L.P.



#### WARRANTY LIMITATIONS: WE ARE NOT RESPONSIBLE FOR:

- Damage or repairs required as a result of faulty installation or application
- Damage or repairs required as a result of floods, fires, wind, lightning, accidents, corrosive atmosphere or other conditions beyond our reasonable control
- Damage or repairs required as a result of the use of components or accessories not compatible with the unit
- Units installed outside of the United States and Canada
- Normal maintenance, as described in the installation and operating manual, such as cleaning of the coils, filter cleaning and/or replacement, or damage caused by failure to perform such maintenance
- Parts or accessories not supplied or designated for use by us
- Damage or repairs required as a result of any improper use, maintenance, operation or servicing
- Damage or failure to start due to interrupted and/or inadequate electrical service
- Changes in the appearance of the unit that do not affect its performance
- Replacement of fuses and replacement or resetting of circuit breakers

**THIS WARRANTY IS THE ONLY EXPRESS WARRANTY PROVIDED ON THE UNITS COVERED; AND ANY IMPLIED WARRANTIES, INCLUDING ANY IMPLIED WARRANTY OF MERCHANTABILITY OR FITNESS FOR A PARTICULAR PURPOSE ARE LIMITED TO THE DURATION OF THIS WARRANTY.** Some states do not allow limitations on how long an implied warranty lasts, so the above limitation may not apply to you.

**WHETHER ANY CLAIM IS BASED ON NEGLIGENCE OR OTHER TORT, BREACH OF WARRANTY OR OTHER BREACH OF CONTRACT, OR ANY OTHER THEORY, IN NO EVENT SHALL WE BE LIABLE FOR INCIDENTAL OR CONSEQUENTIAL DAMAGES, INCLUDING BUT NOT LIMITED TO LOST PROFITS, LOSS OF USE OF A UNIT OR OTHERWISE.** Some states do not allow the exclusion or limitation of incidental or consequential damages, so the above exclusion may not apply to you.

This warranty gives you specific legal rights, and you may also have other rights which vary from state to state.



## WARRANTY TO COMMERCIAL CUSTOMERS

### RAC WINDOW TYPE H & C (AE, AH, PBC, PBE, PBH)

This warranty is extended to commercial customers only. A distinct warranty is extended to purchasers for personal, family or household use.

Amana® brand RAC window-type heating or air conditioning units identified as AE, AH, PBC, PBE and PBH units are warranted by Goodman Company, L.P. to commercial customers against defects in materials and workmanship under normal use and maintenance, as provided below.

**FIRST-YEAR COVERAGE (ENTIRE UNIT):** We will repair or replace, free of charge (to include labor), any part of a unit that proves to be defective due to workmanship or materials within the first year after the date of purchase.

**SECOND THROUGH FIFTH YEARS SEALED SYSTEM COVERAGE:** During the 2<sup>nd</sup> through 5<sup>th</sup> years after the date of purchase, we will repair (to include labor) any refrigerant leaks caused by defects in workmanship or material of a unit, and will repair or replace (to include labor) any portion of the evaporator coil, condenser coil, compressor, reversing valves or connecting tubing that proves to be defective, in workmanship or materials.

If the date of purchase cannot be verified, the warranty period begins three months after the month of manufacture (indicated by the first four digits of the unit's serial number (yyymm)).

Any part replaced or leak repaired under this warranty is warranted only for the unexpired portion of the original warranty term.

The above remedies are our only responsibilities, and the customer's only remedies, under this warranty. For warranty credit, any defective part must be returned to an Amana® brand heating and air conditioning products distributor by an authorized Amana® brand service; and all warranty service must be performed by an authorized Amana® brand service. To locate an authorized Amana® brand service, contact Goodman Company Consumer Affairs at the number or address found at the bottom of this certificate.

Model # & Serial # \_\_\_\_\_

Date of Purchase \_\_\_\_\_



is a registered trademark of Maytag Corporation or its related companies and is used under license to Goodman Company, L.P., Houston, TX. All rights reserved.

For service, contact an Authorized Amana® Brand Service.

For answers to questions regarding the above or to locate an authorized service, contact

**Goodman Consumer Affairs • 7401 Security Way • Houston, Texas 77040**

1-877-254-4729 inside U.S.A. • 1-713-861-2500 outside U.S.A.

Part No. PW-343  
5/2010

Goodman will not pay for electricity or fuel costs, or increases in electricity or fuel costs, for any reason, including additional or unusual use of supplemental electric heat. This warranty does not cover lodging.

#### WARRANTY LIMITATIONS: WE ARE NOT RESPONSIBLE FOR:

- Damage or repairs required as a result of faulty installation or application
- Damage or repairs required as a result of floods, fires, wind, lightning, accidents, corrosive atmosphere or other conditions beyond our reasonable control
- Damage or repairs required as a result of the use of components or accessories not compatible with the unit
- Units installed outside of the United States and Canada
- Normal maintenance, as described in the installation and operating manual, such as cleaning of the coils, filter cleaning and/or replacement, or damage caused by failure to perform such maintenance
- Parts or accessories not supplied or designated for use by us
- Damage or repairs required as a result of any improper use, maintenance, operation or servicing
- Damage or failure to start due to interrupted and/or inadequate electrical service
- Changes in the appearance of the unit that do not affect its performance
- Replacement of fuses and replacement or resetting of circuit breakers

**THIS WARRANTY IS PROVIDED IN LIEU OF ANY OTHER WARRANTIES, EXPRESS OR IMPLIED, INCLUDING ANY IMPLIED WARRANTY OF MERCHANTABILITY OR FITNESS FOR A PARTICULAR PURPOSE. WHETHER ANY CLAIM IS BASED ON NEGLIGENCE OR OTHER TORT, BREACH OF WARRANTY OR OTHER BREACH OF CONTRACT, OR ANY OTHER THEORY, IN NO EVENT SHALL WE BE LIABLE FOR INCIDENTAL OR CONSEQUENTIAL DAMAGES, INCLUDING BUT NOT LIMITED TO LOST PROFITS, LOSS OF USE OF A UNIT OR OTHERWISE.**









is a registered trademark of Maytag Corporation or its related companies and is used under license to Goodman Company, L.P., Houston, TX. All rights reserved.

[www.amana-ptac.com](http://www.amana-ptac.com)

© 2010 Goodman Company, L.P.