

**ARWL129NAADA**

32.0" x 23.38" x 22.0" (H x W x D)

ADA compliant ENERGY STAR qualified 110V washer, built by Ariston in Italy

**Highlights:**

16 wash cycles offer the appropriate care for every fabric

ENERGY STAR qualified performance to save on electricity and water usage

32" height fits in ADA compliant settings

Super silent operation with a unique tri-phase motor



Slim undercounter dimensions	Just under 24" wide for an easy fit
ADA compliant	32" height allows unit to be installed under lower ADA compliant counters
Built-in capable	Unit can be built-in for recessed installation with zero clearance
Front-loading design	Easy to load with a glass door for a clear view
16 wash settings	Get the proper fabric care with settings for regular and colored cottons, permanent press, quick wash, mixed load, bright white, jeans, active wear, infant wear, lightly soiled, delicates, wool, silk curtains, and three partial wash cycles
Super silent operation	Special tri-phase motor ensures low noise operation
Stainless steel drum	Durable interior holds up load after load
Delay start option	Allows you to pre-set your laundry for the ideal finish time

Start/pause function	Lets you pause the wash cycle to add or remove fabric
Detergent dispenser	Pull-out compartment for prewash, regular detergent and fabric softener

## Specifications:

Height	32.0"
Width	23.38"
Depth	22.0"
Shipping Weight	158.0 lbs.
Weight	148.0 lbs.
US Electrical Safety	UL
Modified Energy Factor	2.16
Canadian Electrical Safety	ULC
Amps	4.0
Voltage/Frequency	115 V AC/60 Hz
Energy Usage/Year	105.0 kWh/year
Depth with door at 90°	37.88"
Style	Front Loading
Door Window	true
Control Type	Dial
Number of Dispensers	3
Leveling Legs	true
Max Drum Spin Speed	1200.0
Water Factor	4.96
Max Clothes Weight per Wash	15.0 lbs.
Dispenser Compartment	true
Parts/Labor Warranty	1 Year

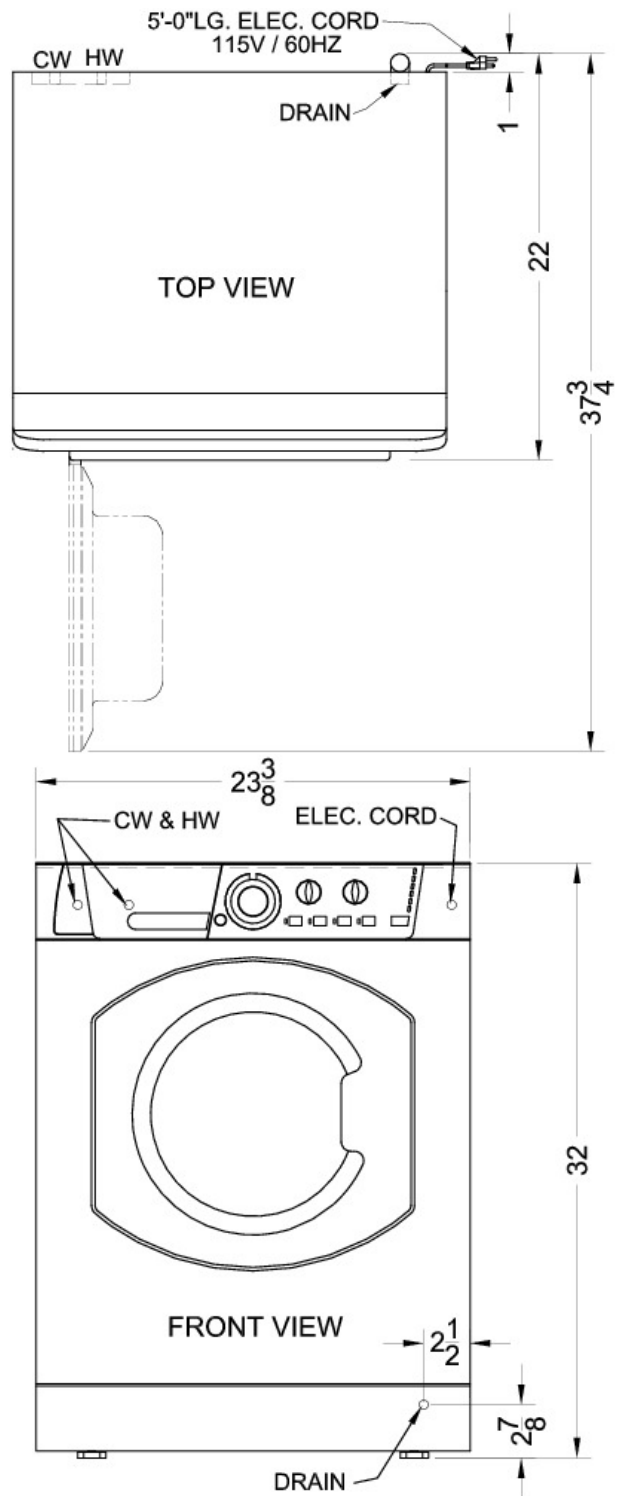

Summit Appliance Division, Felix Storch, Inc.  
 770 Garrison Ave • Bronx, NY 10474  
 Phone: 718-893-3900 • Fax: 718-842-3093  
 Email: [info@summitappliance.com](mailto:info@summitappliance.com)