

10.08 FROM TOP OF UNIT
TO ϕ OF SCREEN

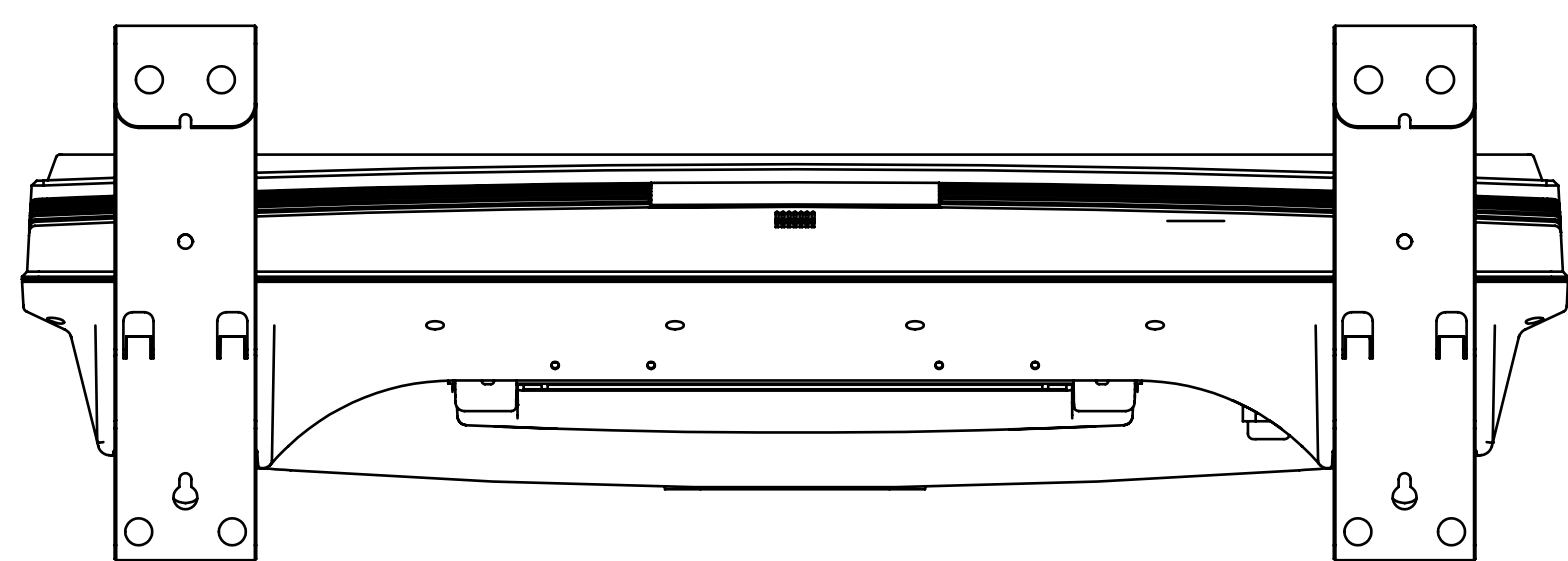
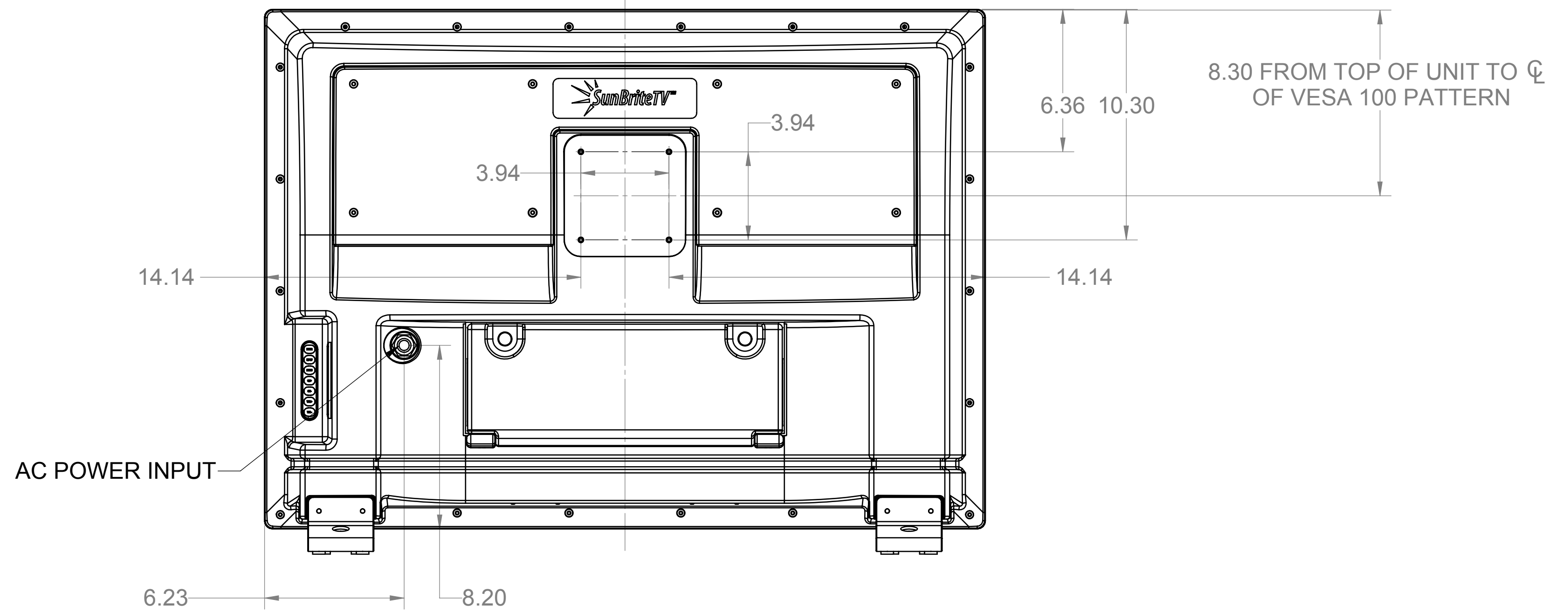
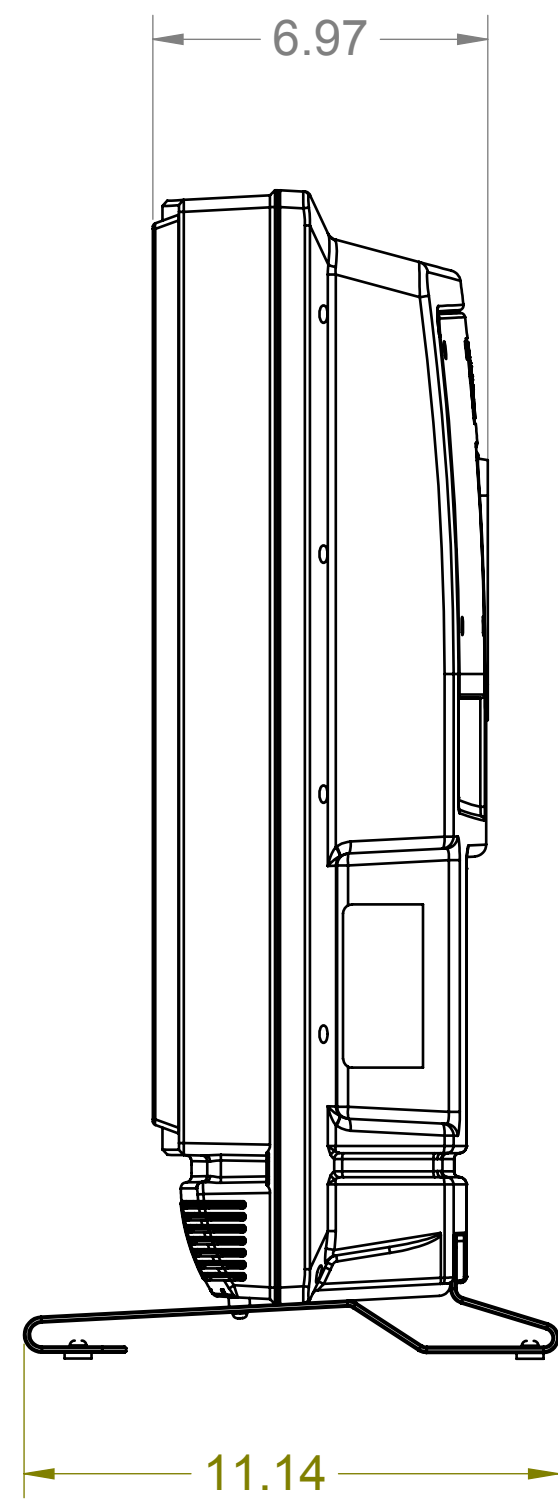
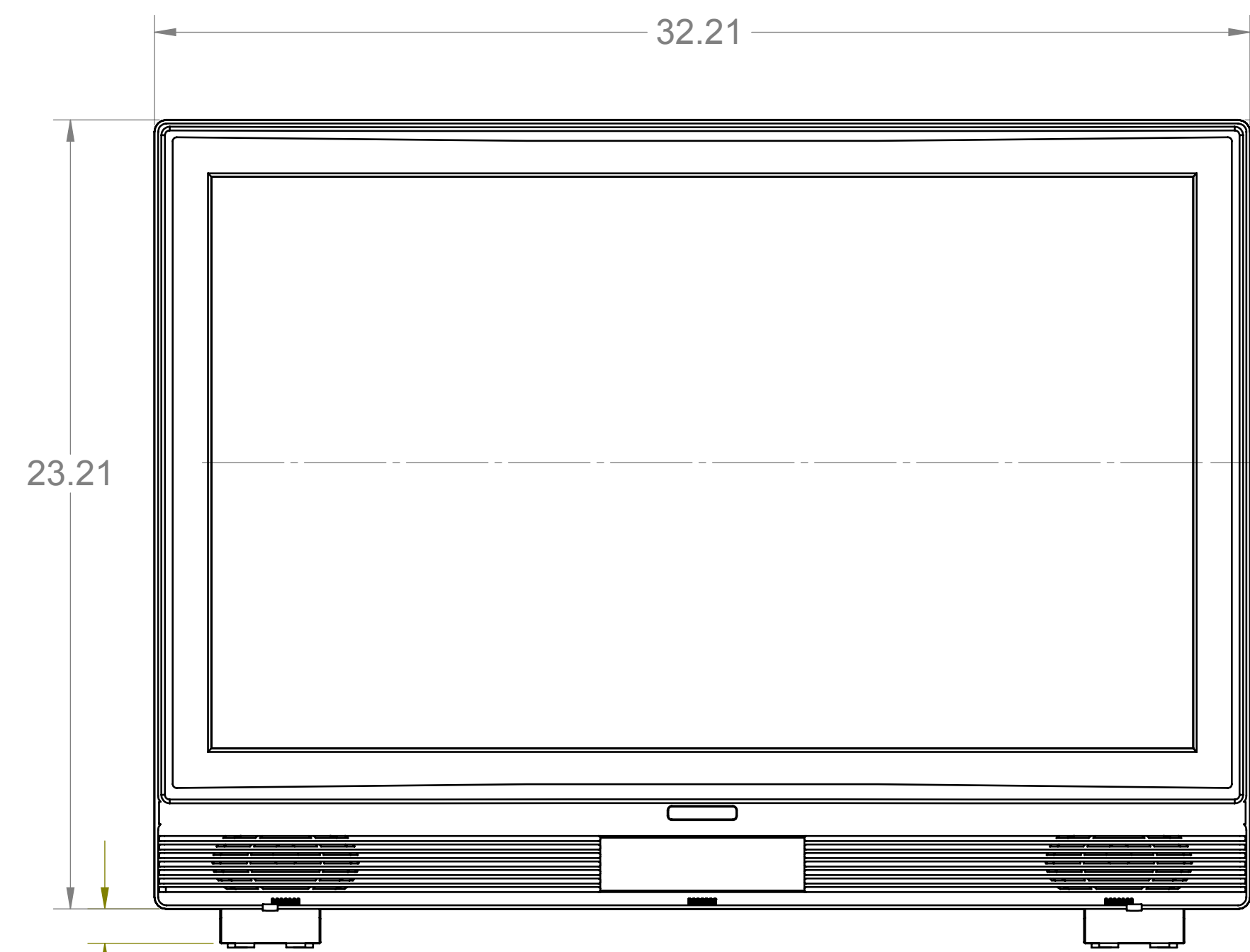

DIMS INCHES mm X .04 ±0.04 ±1 X.X ±0.03 ±0.5 X.XX ±0.015 ±0.1 X.XXX ±0.005 FRACTIONAL: ±0.03 ANGLE ±1/2° (BUT NOT OVER 0.03) HOLES ≤ φ .500 +0.003/-0.001 HOLES > φ .500 +0.005/-0.001 LOCATE φ TO ±0.015 (C) CONCENTRICITY 0.003 TIR REMOVE BURRS AND BREAK SHARP EDGES	FINISH:	PROPRIETARY AND CONFIDENTIAL THE INFORMATION CONTAINED IN THIS DRAWING IS THE SOLE PROPERTY OF SUNBRITE TV LLC. ANY REPRODUCTION IN PART OR AS A WHOLE WITHOUT THE WRITTEN PERMISSION OF SUNBRITE TV LLC IS PROHIBITED.	
	DRAWN TRW	TITLE:	
	CHECKED TRW	SCALE: 1:4	DO NOT SCALE DRAWING DWG. NO.
	ENG APPR. TRW	DATE:	SHEET 1 OF 3

08011501_sb3230