

USE & CARE GUIDE

Integrated Refrigeration



Contents

Integrated Refrigeration	3
Integrated Features	4
Integrated Models	5
Integrated Use & Care	10
Keeping Food at Its Best	21
Food Storage Recommendations	25
Troubleshooting Guide	31
Service Information	34
Sub-Zero Warranty	35

Features and specifications are subject to change at any time without notice. Visit our website, subzero.com for the most up-to-date information.

Important Note

To ensure the safe and efficient use of Sub-Zero equipment, please take note of the following types of highlighted information throughout this guide:

IMPORTANT NOTE highlights information that is especially important.

CAUTION signals a situation where minor injury or product damage may occur if instructions are not followed.

WARNING states a hazard that may cause serious injury or death if precautions are not followed.



Thank You

Thank you for purchasing your new Sub-Zero integrated unit. With Sub-Zero, you can rely on a 60-year tradition of quality and reliability. The integrated line brings together the latest and finest features in home refrigeration to give you the freshest food possible.

Your Sub-Zero is protected by a warranty that is one of the finest in the industry. Take a moment to read the warranty statement at the end of this guide and refer to it should service become necessary.

This use & care guide will answer most of your questions about the features, operation and maintenance of your integrated unit. If you have questions that are not addressed here, call Sub-Zero customer care at 800-222-7820 or visit our website, subzero.com.

Integrated Refrigeration

The Sub-Zero integrated line brings you true innovation! It is the first integrated systems approach to domestic refrigeration, offering you three significant advantages.

- Integrated refrigeration systems gives you the choice of refrigerator or freezer options to meet your needs. The ergonomic division of space increases your access to storage areas.
- Integrated refrigeration systems gives you the choice of location of refrigeration units throughout your kitchen and home. This helps you meet your individual needs for the way you use refrigeration within your home.
- Integrated refrigeration systems gives you total aesthetic integration with cabinets you have chosen. Refrigeration units, in essence, are refrigeration cabinets. They literally become a part of the kitchen furniture.

Integrated Features

- Integrated refrigeration systems offer “point-of-use” refrigeration that integrates with cabinetry anywhere in the home.
- Integrated combination units, except model 700BC(I), have the Sub-Zero dual refrigeration system, which ensures the freshest food and energy efficiency at the same time. You have precise independent control of the refrigerator and freezer sections.
- Integrated models meet strict Department of Energy requirements.
- A microprocessor controls all electronic functions, including temperature, adaptive defrost, lights, cooling fan and door/drawer ajar warning. Electronic digital controls lets you monitor and adjust all temperature zones in the unit.
- Seamless molding forms the front of each unit’s interior, giving a sculptured look that is both utilitarian and elegant.
- Flat to the ceiling, superior lighting provides white, efficient light in the top compartment and drawers.
- A single sculptured molding, with tempered glass molded into it, forms each sealed, adjustable shelf. This design feature prevents spills from dripping throughout the unit.
- The enclosed deli drawer gives you a convenient area for deli foods or other small items.
- Models IC-27R and 736TCI have a sealed crisper with removable dividers. It is large and deep, with smooth sides for easy cleaning.
- A divided dairy compartment is standard on model IC-27R and tall refrigerator and combination units. This adjustable compartment is a convenient place for dairy foods and small items that need a fresh environment.
- All column and tall models have adjustable door shelves. Column models also feature shallow door shelves.
- An interchangeable lift-up crisper cover provides for maximum humidity in the base and tall refrigerator units and in the upper refrigerator drawer of base combination units, helping you keep produce at its best quality, longer. The middle drawer of column model IC-27R is a sealed crisper.
- For models with an automatic ice maker, the clear molded ice container is easily removable.
- The dual-action hinge has a built-in 90° door stop.
- Sub-Zero products are covered by a two, five and twelve year residential warranty (exclusions apply). See warranty details at the end of this guide.



Drawer models are certified by Star-K to meet strict religious regulations in conjunction with specific instructions found on www.star-k.org. Column and tall models require installation of a harness kit. For details about the harness kit, contact your authorized Sub-Zero dealer.

Model IC-27R

ALL REFRIGERATOR COLUMN

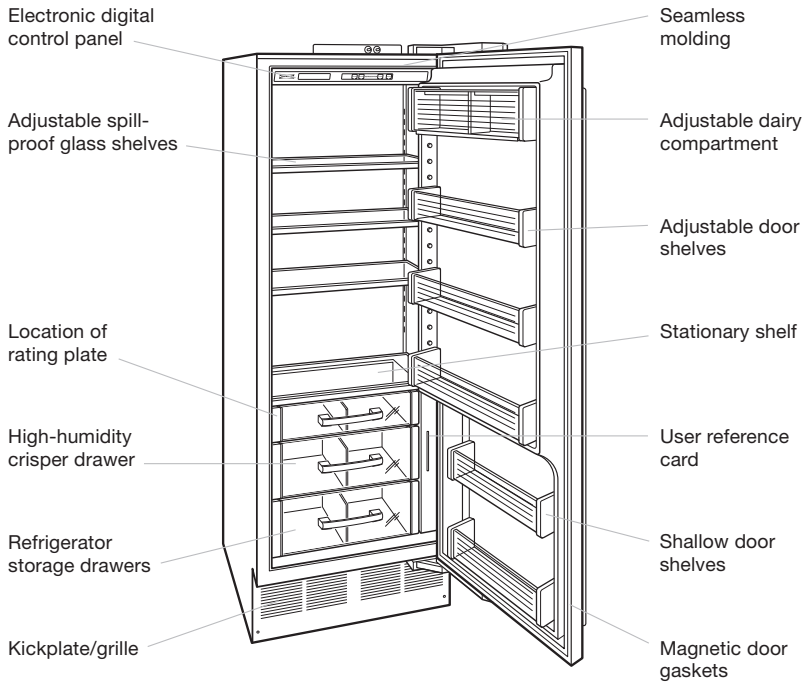

Model IC-27FI

ALL FREEZER COLUMN

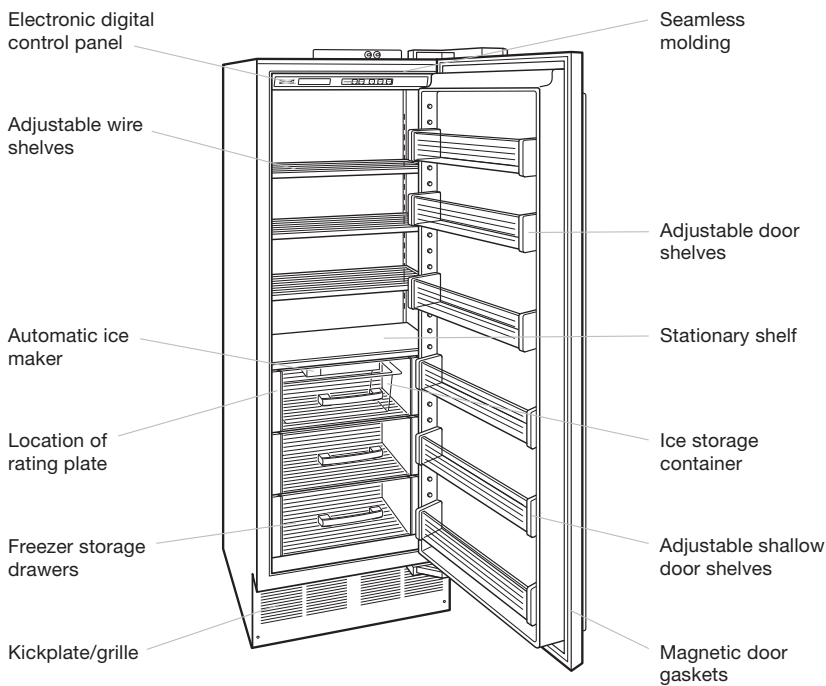

Model 700TR

ALL REFRIGERATOR

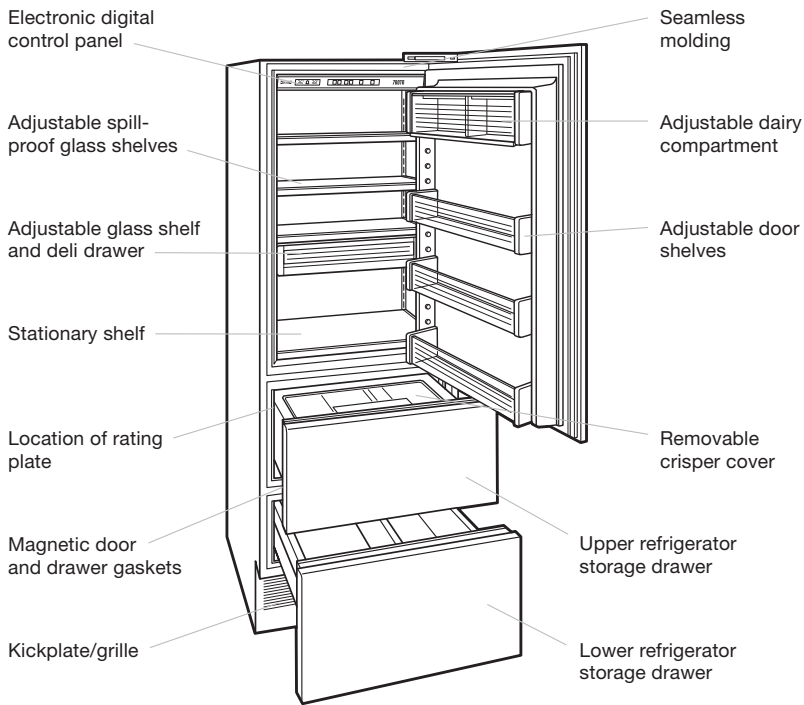

Model 736TR

ALL REFRIGERATOR

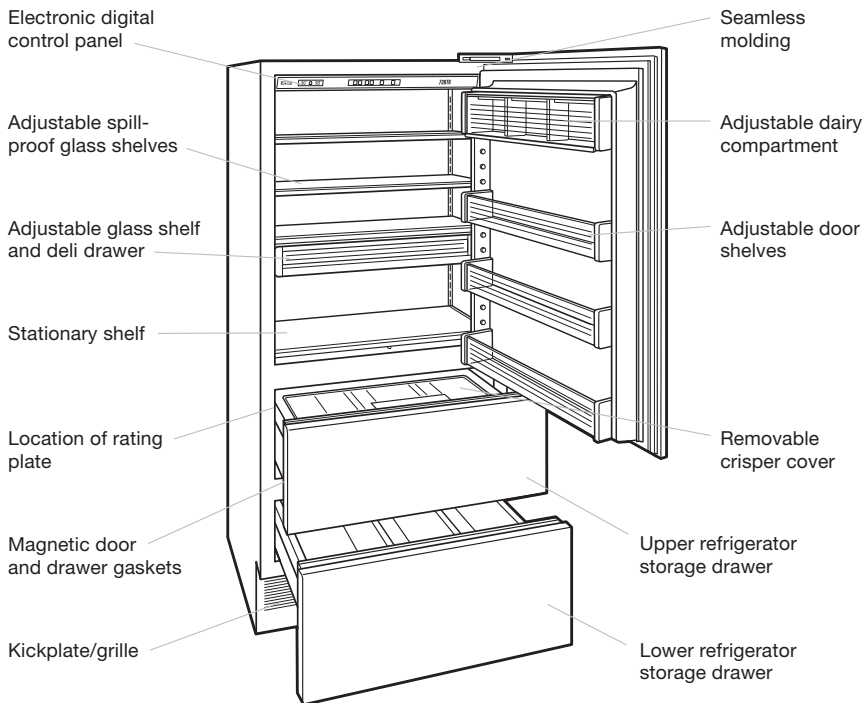

Model 700TFI

ALL FREEZER

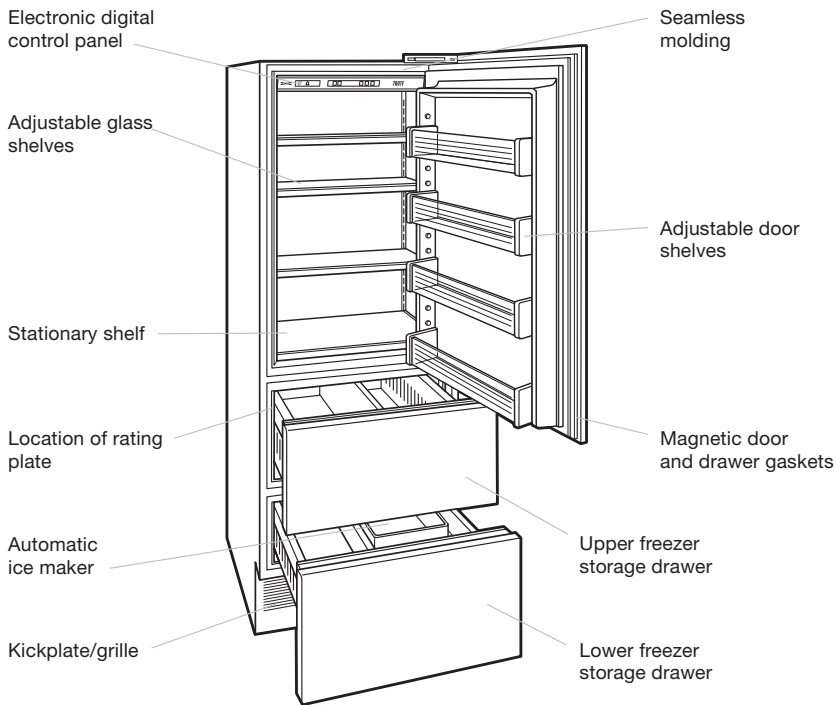

Model 736TFI

ALL FREEZER

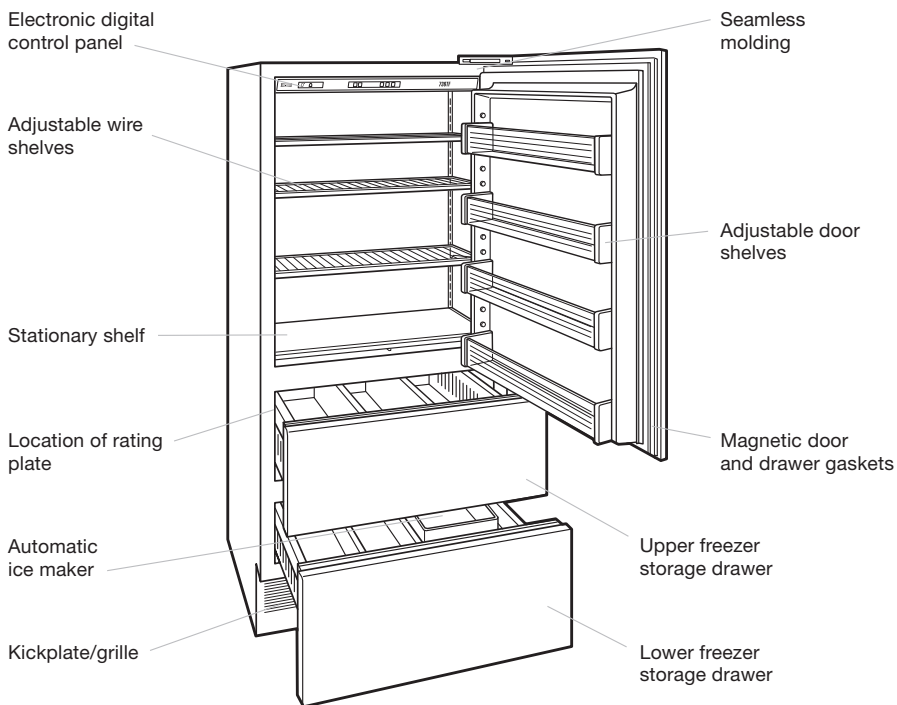

Model 700TCI

COMBINATION REFRIGERATOR / FREEZER

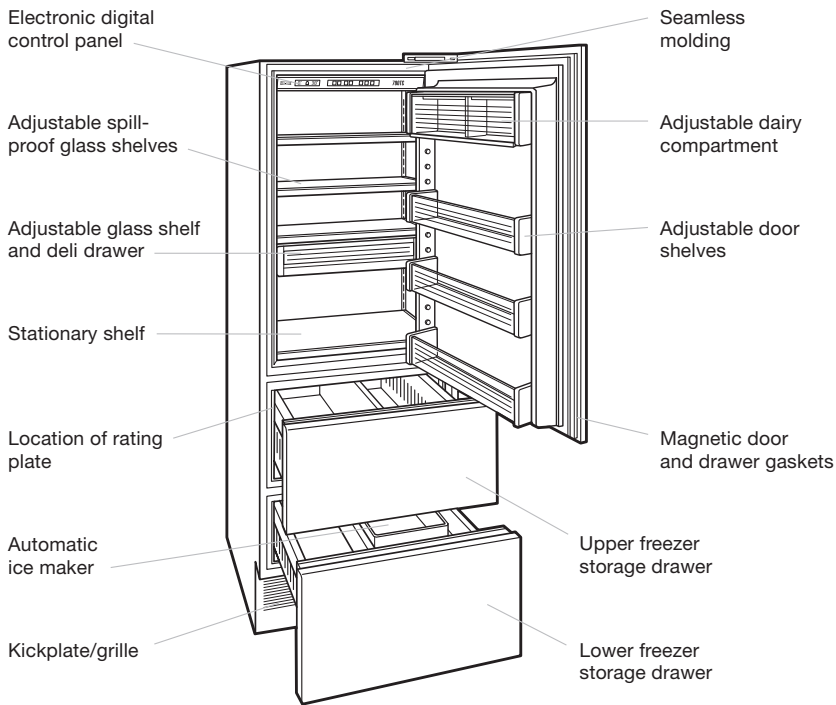

Model 736TCI

COMBINATION REFRIGERATOR / FREEZER

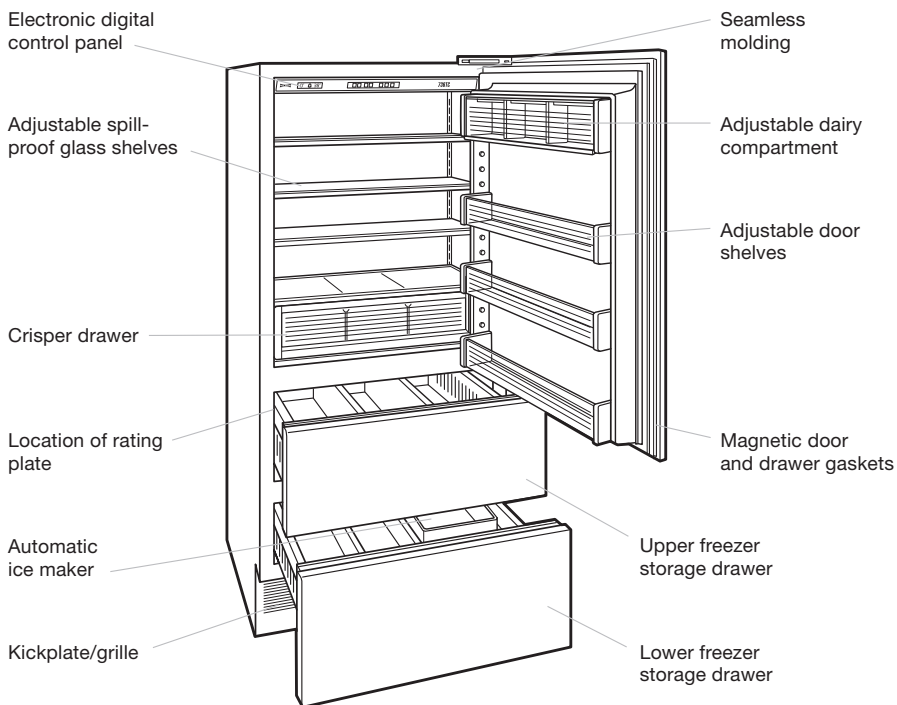

Model 700BR

REFRIGERATOR DRAWERS

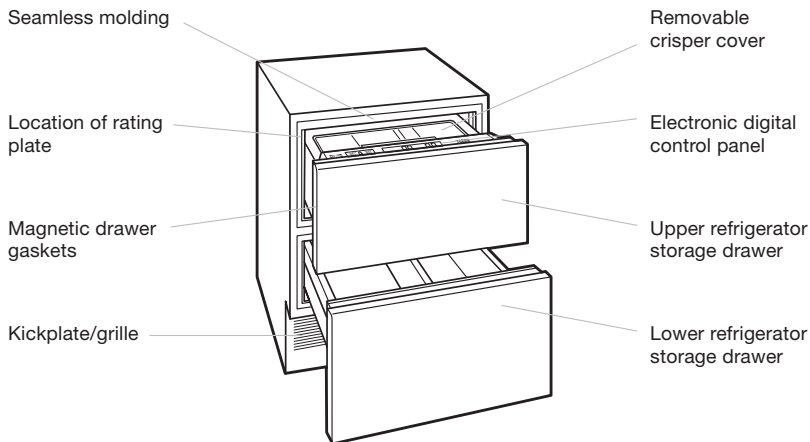

Model 700BF(I)

FREEZER DRAWERS

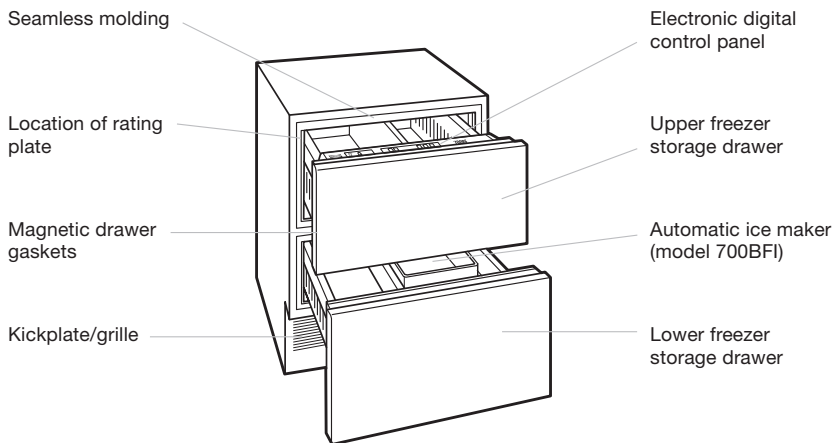

Model 700BC(I)

REFRIGERATOR / FREEZER DRAWERS

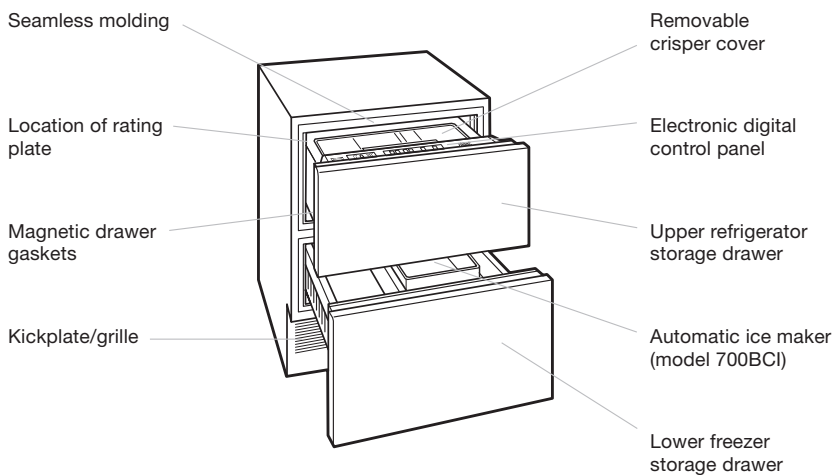

Electronic Control System

The electronic control system of your Sub-Zero integrated unit provides you with the best control of your refrigerated foods. By maintaining recommended refrigerator and freezer temperatures, you can keep food safe and retain the best quality possible.

A microprocessor accurately controls the temperature of the cooling zones. It samples the temperature every second and makes adjustments to maintain the temperature you have indicated.

The electronic control panel is located on the top of column and tall models, and in the top drawer of drawer models. All of the essential controls and information are displayed in this easy-to-reach-and-see panel. Refer to the illustrations below for location of the electronic control panel. Note that for single zone units and units that cannot support an ice maker, the electronic control panel will be slightly different.

LCD DISPLAY

The liquid crystal display (LCD) located on the electronic control panel shows the actual temperature of different zones in your unit.

If there is a temperature or ice maker problem, you'll be alerted by a flashing SERVICE indicator light in the LCD display.

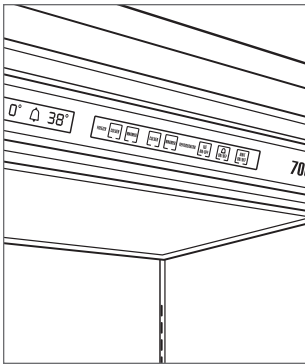

Control panel (tall model shown).

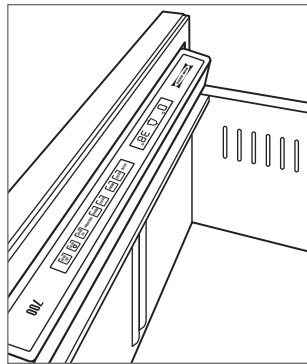

Drawer unit control panel.

TEMPERATURE CONTROL

Integrated units are factory preset to maintain refrigerator zones at 38°F (3°C) and freezer zones at 0°F (-18°C). The temperature range for refrigerator zones is 34°F (1°C) to 45°F (7°C) and the temperature range for freezer zones is -5°F (-21°C) to +5°F (-15°C).

For combination models, there are two sets of WARMER and COLDER key pads on the electronic control panel. One is for the upper refrigerator zone and the other for the lower freezer drawers. Models 700TR and 736TR also have two sets of key pads, one for the upper zone and the other for the drawers. Column models and single-zone refrigerator and freezer units have only one set of WARMER and COLDER key pads.

The COLDER key pad allows you to decrease the temperature of a selected zone in one-degree increments.

Similar to the COLDER key pad, you can raise the temperature in any zone in one-degree increments by pressing the WARMER key pad.

IMPORTANT NOTE: Always allow 24 hours for the unit to reach the temperature you set.

POWER

The UNIT ON/OFF key pad (POWER for column models), located on the electronic control panel, will turn off all electrical power to the unit. This key pad can be used for shutting down the unit for servicing or extended vacations.

Electronic Control System

ICE MAKER CONTROL

The ICE ON/OFF key pad, located on the electronic control panel, turns the automatic ice maker system on and off. When the ice maker is on, the word 'ICE' will be illuminated in the LCD display.

ALARM FEATURE

All integrated models have an alarm feature that will make an audible beeping sound if a door or drawer is left ajar.

An alarm will sound if the door is left ajar or a drawer is left open. When the alarm is activated, the 🔔 symbol in the LCD display will be visible. You can turn the alarm on or off with the 🔔 ON/OFF key pad, or stop it with this control once the alarm has sounded.

When your alarm is on, the 🔔 symbol will be illuminated in the LCD display on the electronic control panel. To turn the alarm off, press the 🔔 ON/OFF key pad one time to make the 🔔 symbol disappear from the display.

TEMPERATURE DISPLAY

The electronic control system can display temperatures in Fahrenheit (°F) or Celsius (°C).

To convert Fahrenheit to Celsius, turn the unit off then back on. Within the first minute after turning the unit on, press and hold the 🔔 ON/OFF key pad and the UNIT ON/OFF key pad (POWER for column models) simultaneously for five seconds, then release. A 'C' will appear in the upper right of the temperature readings on the LCD. Follow the same procedure to convert from Celsius to Fahrenheit.

Use the COLDER and WARMER key pads to check the set point range(s) and verify that the temperature units were changed.

SABBATH MODE (STAR-K)

Sabbath mode is available for the observance of certain religious holidays. This mode turns off the lights, ice maker system and door alarm and prevents them from turning on again. Normal cooling operations will still take place.

Drawer models are certified by Star-K to meet strict religious regulations in conjunction with specific instructions found on www.star-k.org. Column and tall models require the installation of a harness kit. For details about the harness kit, contact your authorized Sub-Zero dealer.

To initiate Sabbath mode, the unit must first be turned off with the UNIT ON/OFF key pad (POWER for column models). When the unit is off, press and hold the UNIT ON/OFF key pad. The unit will turn on as soon as the key pad is pressed. The lights will turn off after holding the UNIT ON/OFF key pad for about 10 seconds. This indicates that the unit has entered Sabbath mode and the key pad can be released.

Sabbath mode can be exited by pressing the UNIT ON/OFF key pad once.

Storage Shelves

ADJUSTABLE SHELVES

Depending on the model, integrated column and tall models have adjustable tempered glass shelves or wire shelves.

To remove or adjust the glass or wire shelves, first tilt the shelf up at the front, then lift it up and out of the tracks on the rear wall of the unit. Refer to the illustration below.

If the door is limited to a 90° opening, you'll need to clear the door shelves in order to remove a shelf. Lift and pivot the end of the shelf nearest the door upward, and remove.

To replace a shelf, insert it in the tracks at the rear of the unit with the front of the shelf raised slightly. As you push the shelf in, lower the front of the shelf until it locks into position.

IMPORTANT NOTE: Always be careful in handling glass shelves to prevent breakage or scratching the interior.

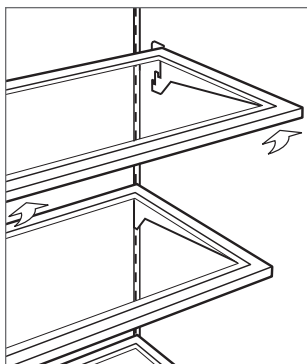

Shelf removal.

STATIONARY SHELF

The stationary glass shelf of column and tall units, except model 736TCI, should be placed on the bottom portion of the top compartment with the beveled edge of the shelf support facing front. When installed properly, the rear support legs will space the shelf away from the back wall to ensure an even flow of air through the unit.

DOOR SHELVES

The door shelves and dairy compartment of column and tall models are adjustable within the guides of the door liner. The two shallow door shelves of column model IC-27R are removable, but not adjustable.

To remove door shelves or the dairy compartment, lift straight up and out from the bottom as shown in the illustration. To replace, select a desired position and slide the door shelf or dairy compartment down into the guides.

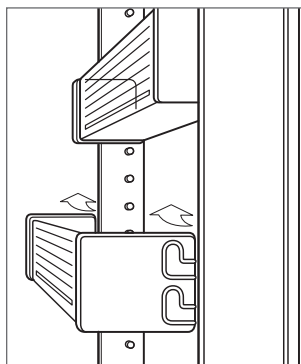

Door shelf removal.

Refrigerator Storage

DELI DRAWER AND SHELF

The one-piece deli drawer and shelf assembly in models 700TR, 700TCI and 736TR is easily removed for cleaning and repositioning. The deli drawer is convenient for storage of small items and for keeping deli items fresh. Refer to the illustration below

Remove this assembly in much the same way you remove the adjustable glass shelves.

CRISPER (MODEL 736TCI)

The sealed crisper with two dividers in model 736TCI offers convenient storage of fruits and vegetables.

To remove the crisper, first lift the glass shelf off of the plastic side supports, then lift the crisper bin up off of the bin cradle. Refer to the illustration below.

To replace the crisper, place the bin on top of the bin cradle. The groove across the bottom of the bin should align with the crossbar at the front of the cradle. Place the glass shelf on top of the side plastic side supports.

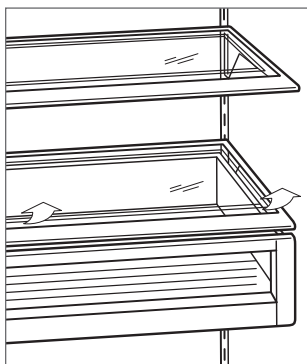

Deli drawer and shelf.

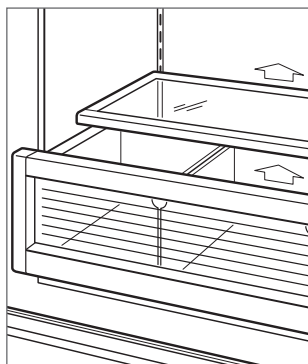

Crisper (736TCI).

STORAGE DRAWERS AND CRISPER (MODEL IC-27R)

Column model IC-27R has two storage drawers and a high-humidity crisper. The drawer front panel is clear so you can easily view the contents. Be sure to unload the storage drawers and crisper before removal.

To remove a storage drawer or the crisper, pull the drawer out until it stops. Lift the front of the drawer slightly and pull straight forward. Refer to the illustration below.

IMPORTANT NOTE: If the door is limited to a 90° door opening, the shallow door shelves will need to be removed in order to remove a drawer.

To reinstall, push the drawer slides back into the refrigerator. Align the drawer with the slides, then push the drawer straight back on to the slides until it stops. Press downward on the front of the drawer to engage the slides.

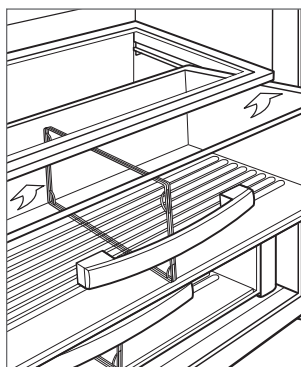

Storage drawer (IC-27R).

Freezer Storage

FREEZER DRAWER (MODEL IC-27FI)

Column model IC-27FI has three wire storage drawers. The drawer front panel is clear so you can easily view the contents. Be sure to unload the freezer drawers before removal.

To remove a freezer drawer pull it out until it stops. Behind the bottom two corners of the front face of the drawer are metal tabs. Pull these tabs toward the front of the drawer and lift and rotate the drawer up. Refer to the illustration below.

IMPORTANT NOTE: If the door is limited to a 90° door opening, the shallow door shelves will need to be removed from the bottom of the door in order to remove a drawer.

To reinstall, push the drawer slides back into the freezer. Align the drawer with the slides and push the drawer straight back onto the slides until it stops. Press downward on the front of the drawer to engage the drawer tabs with the slides.

ICE CONTAINER (MODEL IC-27FI)

The automatic ice maker and ice container of column model IC-27FI are located in the top drawer. To remove the ice container, pull the drawer forward until it stops and lift the ice container out.

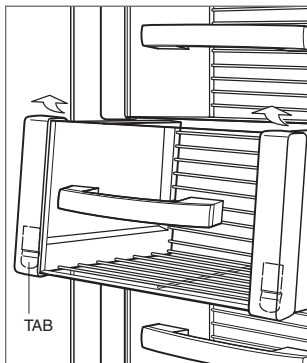

Freezer drawer (IC-27FI).

Drawer Storage

DRAWER REMOVAL

IMPORTANT NOTE: Before removing the top drawer from a drawer unit, you must first disconnect the control cable as shown in the illustration below.

To remove a storage drawer from your integrated tall or drawer unit, pull it open until it stops. Raise the drawer front and pull out as shown in the illustration.

To replace a drawer, raise the front of the drawer up and place onto the drawer slide tracks. Engage the hook at the rear of each slide with slots in the back of the drawer tub. For 36" (914) units, there are tabs on each drawer that must be positioned between the hooks. Then engage the small white pegs at the front of each drawer slide with holes at the front of the drawer tub. Reconnect the control cable.

⚠ CAUTION

You must first disconnect the control cable before removing the top drawer of a drawer unit.

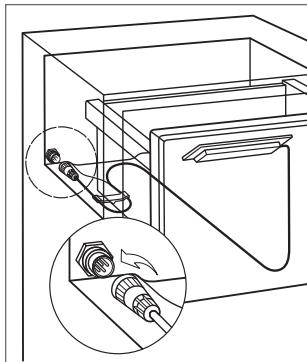

Control cable.

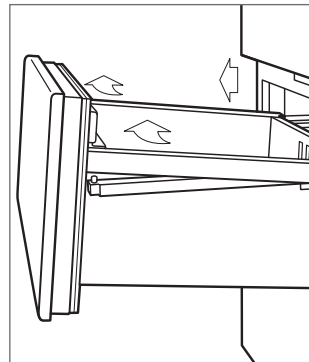

Drawer removal.

REMOVABLE CRISPER COVER

One lift-up crisper cover is standard with each tall and drawer refrigerator unit and the drawer combination unit. The clear-view window allows easy access and visibility of all vegetables stored in the drawer.

You can easily remove this cover for cleaning with soap and water, or move it to another drawer by lifting the front edge up and pulling out from the front. Refer to the illustration below.

IMPORTANT NOTE: For model 700BC(I), drawer combination unit, the removable crisper cover can only be used in the upper drawer.

DRAWER DIVIDER

The divider of the upper drawer is easily removed by pulling forward and sliding the back edge away from the back of the drawer. Reverse this procedure to insert the divider, as shown in the illustration below.

The divider of the lower drawer is removable if there is no ice maker, but screws have to be removed to do so. For units with an ice maker, the lower divider is not removable.

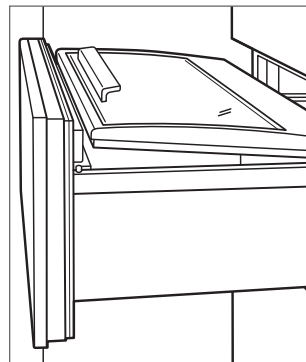

Crisper cover removal.

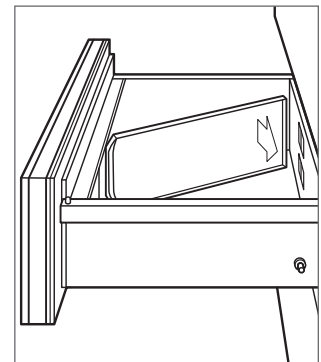

Drawer divider removal.

Ice Maker Operation

The ice maker in your integrated combination or freezer model is fully automatic and has been factory tested. It requires a connection to the house water supply.

To put into operation, the ice maker system must be turned on by the ICE ON/OFF key pad, located on the electronic control panel. Refer to ice maker control on page 11.

For column models, the ice maker must be turned off at the control panel when the ice storage container is removed. For tall and drawer models, the ice maker shuts off when you remove the ice storage container. When you reinstall the container, the ice maker will resume ice production.

IMPORTANT NOTE: The first container filled with ice should be discarded, as with any new connection there may be impurities in the ice from the water supply line.

Sounds

You may hear some noises in the normal operation of the integrated unit. Surrounding acoustics like walls, floors and cabinets may affect the sound of your unit. For example, a gurgling or running water sound is probably refrigerant circulating through the tubing.

During the ice maker cycle you may hear the sound of ice dropping into the container or the solenoid valve operating while refilling the ice maker with water. During the freezer defrost you may hear crackling and/or sizzling as the heat from the defrost element clears the frost from the freezer coil and water runs into the water pan.

While the compressors are in operation, you may hear a slight hum. During the start-up and shutdown of the compressor, you may feel vibration for a few seconds.

Some of these noises may be enhanced when the unit's door or drawers are open.

Lighting Information

CABINET LIGHTING

Cabinet lighting for integrated column and tall models use standard 40-watt appliance bulbs.

To replace the light bulbs, you must first remove the light shield. Place your hands under the light shield and release the two clips on the back, then lift up and slide back slowly until the key slots on the side of the light shield drop past the mounting studs in the side walls. Remove the light shield. The bulbs are now accessible. Replace the bulbs and follow the reverse steps to reposition the light shield. Refer to the illustrations below.

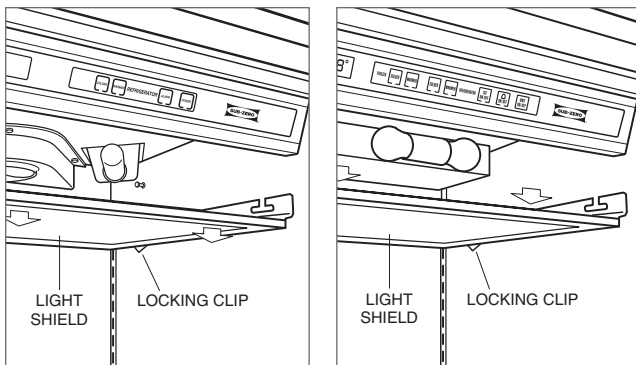

Cabinet lighting (column model).

Cabinet lighting (tall model).

DRAWER LIGHTING

Each drawer compartment has a standard 25-watt appliance bulb recessed into the top of the compartment. Refer to the illustration below.

To replace the light bulb, pull the drawer out to its full extension or remove the drawer completely. Refer to drawer removal on page 15. Replace the bulb and follow the reverse steps to reinstall the drawer.

CRISPER LIGHTING (MODEL IC-27R)

Crisper drawer lighting for model IC-27R is located behind the upper crisper drawer and mounted to the back wall of the refrigerator. To remove the light shield, first remove the crisper drawer. Next, remove the upper crisper shelf. Then place both hands under the bottom right and left sides of the light shield and push upward. Refer to the illustration below.

⚠ WARNING

Shut off power to the unit at the circuit breaker before replacing light bulbs. Wear protective gloves when handling bulbs.

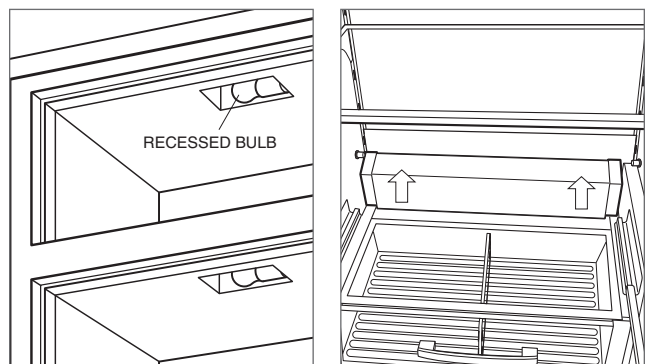

Drawer lighting.

Light shield removal (IC-27R).

Cleaning

INTERIOR CLEANING

It is necessary to keep your integrated unit clean to ensure smooth operation and keep food safe. Wipe up any spills immediately.

To clean interior surfaces and removable parts, wash with a mild solution of soap and lukewarm water with a little baking soda. Do not use vinegar or alcohol-based cleaners. Rinse and dry thoroughly. Avoid getting water on the lights and control panel. Do not use abrasive cleaners, as these may scratch interior surfaces.

⚠ CAUTION

Do not use hot water to clean glass shelves until they have come to room temperature. Extreme temperature may cause the glass to break.

STAINLESS STEEL EXTERIOR

To clean the exterior of a stainless steel model, use a soft, nonabrasive stainless steel cleaner like Signature polish and apply with a soft lint-free cloth.

Signature polish is available from Signature Limited Laboratory, P. O. Box 13436, Dayton, Ohio 45413, or call 877-376-5474.

To bring out the natural luster of the stainless steel, lightly wipe the surface with a water-dampened microfiber cloth followed by a dry polishing chamois. All work should follow the grain direction of the finish. Better results are obtained by keeping the cloth in continuous contact with the stainless steel.

⚠ CAUTION

Do not use a metallic or highly abrasive cleaner or cloth, as this will scratch the stainless steel finish.

Cleaning

CONDENSER CLEANING

For all integrated models, the condenser is located at the bottom of the unit, behind the kickplate/grille. To clean the condenser area, remove the kickplate/grille by removing the screws holding it in place. The condenser is now accessible for cleaning. Using a soft bristle brush, vacuum to remove dust and lint from the condenser. Refer to the illustration below.

IMPORTANT NOTE: To ensure efficient performance of your integrated unit, the condenser must be cleaned every three to six months under normal use. If you have pets, it may be necessary to clean the condenser more often.

⚠ CAUTION

Failure to clean the condenser could result in temperature loss or mechanical failure or damage.

⚠ CAUTION

Before cleaning the condenser, shut off power to the unit at the control panel. Wear gloves to avoid injury from sharp condenser fins.

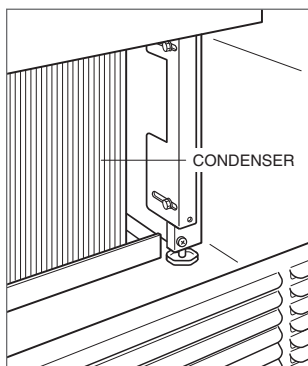

Location of condenser.

Vacation Time

For extended vacations, shut off power to the unit by pressing the UNIT ON/OFF key pad (POWER for column models). Empty all contents and block the door and drawers open slightly. A one-inch space will let fresh air in to keep the interior dry.

IMPORTANT NOTE: Moisture accumulates in a unit that has been shut off as it warms to room temperature, even if it has only been in service temporarily and later shut off. Blocking the door and drawers open slightly will allow the moisture to escape.

For short vacations, remove all perishable items. Shut off the ice maker by pressing the ICE MAKER key pad and empty the ice container. It is not necessary to change the control settings.

If your religious observances require turning off the lights and ice maker, see Sabbath mode on page 10.

⚠ CAUTION

Moisture accumulation can damage interior metal components.

90° Door Stop

Integrated column and tall models are equipped with a built-in 90° door stop. You can easily actuate the stop by using a blade-type screwdriver and advancing the cam in both the top and bottom door hinges.

You must actuate both stops at 90° if you want to safely use the door. You can go to the maximum 105° opening by using the screwdriver and advancing the cam to the next stop.

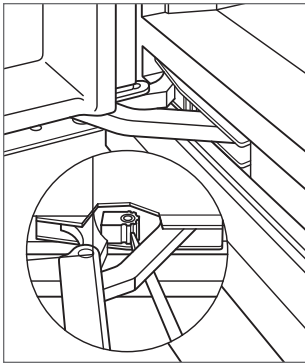

90° door stop.

⚠ CAUTION

When the door is open to 105°, the door panel, depending on its thickness, may strike the face frame of the unit causing serious damage.

⚠ WARNING

The door swing may cause severe finger pinching or damage to the unit. Watch that fingers are not placed in the door opening on the hinge side when the door is open.

Keeping Food Fresh

Your Sub-Zero unit features a unique refrigeration system to keep food fresher longer. However, the quality and safety of your food also depends on how it is handled.

The information in this section gives you the most up-to-date handling and storage recommendations to help you keep food at its best. If you have specific questions that are not addressed here, contact a university, county extension service or your local utility company.

Most food inevitably deteriorates over time. From the very beginning until it is consumed, food undergoes changes. Microorganisms get into food, multiply and cause spoiling.

Enzymes that occur naturally in food continue the ripening process even after the food is harvested. Improper temperatures cause food to deteriorate faster. Changes in humidity cause wilting and shriveling that can lead to spoiling.

Sub-Zero's unique refrigeration system is specifically designed to combat these changes and keep your food fresh longer. The individual refrigerator and freezer systems have been designed to maintain accurate, consistent temperatures and proper humidity levels for longer food life expectancy. Dual refrigeration eliminates transfer of fresh food odors to frozen food or ice and does not freeze the moisture out of the air in the fresh food section.

In addition, good handling practices can minimize the rate of changes in food.

HANDLING RECOMMENDATIONS

- Follow the recommended storage times and temperatures in this guide. Your Sub-Zero unit helps to slow the ripening process by tailoring temperatures to each section as needed.
- Use specially designed compartments for dairy foods, deli foods and fresh produce. These compartments maintain temperature and humidity levels that keep specific food groups fresh.
- Rotate food in refrigeration units, using a first-in, first-out system.
- When food does spoil, it's usually obvious. It becomes moldy, has an off-odor and looks rotten. But there are times when spoiling may not be so apparent. If you think a food has been stored too long, discard it. Do not taste it to check if it's okay.

Keeping Food Safe to Eat

Most food-borne illness is caused by bacteria such as staphylococcus, salmonella, e-coli and clostridium botulinum (the bacteria that causes botulism). These bacteria grow rapidly at temperatures between 40°F (4°C) and 140°F (60°C), a range that's called the "danger zone". Never leave food in the danger zone for more than two hours. When the bacteria have multiplied to the millions in warm temperatures, they cause illness. Some bacteria cause flu-like symptoms, while others cause serious illness or even death. Young children, the elderly and people who are already ill are more likely to become sick from food poisoning.

To reduce your risk of food-borne illness, use the following techniques to keep your food safe to eat:

WHEN YOU'RE SHOPPING

- Place packages of raw meat, seafood or poultry in plastic bags to keep them from dripping on other foods.
- Shop for meat, seafood and poultry last. Do not leave these foods in a hot car when you've finished shopping. Take along a cooler in hot weather or when you have to travel long distances.
- Check 'use by' and 'sell by' dates on foods to make sure they're fresh. Use extra care when buying deli food. Buy only the amount you will use in 1–2 days. Discard hot or cold deli food that has been at room temperature for more than two hours.

WHEN YOU STORE FOOD

- Monitor temperatures of the refrigerator and freezer sections on the electronic control panel of your Sub-Zero unit. Keep the refrigerator temperature at 40°F (4°C) or below and freezer temperature at 0°F (-18°C).
- Follow the recommended refrigerator and freezer storage times and temperatures in this guide.
- Store raw meat, poultry and seafood separate from other foods. Keep juices from these packages from dripping on other food.
- Never taste food that looks or smells strange to test its freshness. Discard it.
- For refrigerator storage, leave raw meat, poultry and seafood in its original wrapper unless it is torn. Repeated handling can introduce bacteria to these foods.
- Wrap food stored in the refrigerator in foil or plastic wrap, or place it in plastic bags or airtight containers to keep it from drying out. Date all packages.
- For freezer storage, use freezer wrap, freezer-quality plastic bags or aluminum foil over the commercial wrap if foods will be stored in the freezer for more than a couple of months. This minimizes dehydration and quality loss. Single layers of aluminum foil may tear and cause freezer burn.

Keeping Food Safe to Eat

WHEN YOU PREPARE FOOD

- Clean everything that comes in contact with food.
- Wash your hands for 20 seconds before and after handling food.
- Sanitize counters, equipment and utensils after handling raw meat, seafood or poultry. Rinse with a diluted chlorine bleach solution of one teaspoon to one quart of water.
- Use clean kitchen towels, sponges and cloths. Replace sponges every few weeks.
- Use disposable plastic gloves if you have an infected cut or burn on your hands.
- Thaw food in the refrigerator or microwave oven, not on the counter. When you thaw food in a microwave oven, cook it immediately.
- Marinate food only in the refrigerator.
- Rinse poultry and seafood in cold water before cooking.
- Avoid cross-contamination in preparing food. Keep raw meat, poultry and seafood and their juices away from other food. For example, do not use the same surface and utensils for preparing raw meat, poultry and seafood that you use for preparing salad ingredients.
- Thoroughly clean your plastic and wooden cutting boards. Wash with hot water and soap and rinse with a diluted chlorine bleach solution of one teaspoon to one quart of water.

WHEN YOU COOK FOOD

- Cook meat to an internal temperature of 165°F (75°C) or above and poultry to 180°F (80°C) or above. For cuts more than two inches thick, use a meat thermometer to check the temperature. For thinner cuts, clear juices (not pink) are a sign of doneness.
- If you are cooking frozen meat or poultry that has not been defrosted, increase the cooking time to 1½ times the time required for thawed items.
- Roast meats or poultry in oven temperatures of 325°F (165°C) or above.
- Cook eggs until the yolk and white are firm, not runny.
- Do not use recipes in which eggs remain raw or partially cooked.
- If your microwave has a temperature probe, use it. Check temperatures of meat and poultry in at least three spots. Rotate foods during microwaving.
- Do not taste raw or partially cooked meat, poultry, eggs or fish.

WHEN YOU HAVE LEFTOVERS

- Refrigerate or freeze cooked leftovers in small, covered containers within two hours after cooking. Make sure there is adequate air space around the containers so that food can cool down quickly.
- Remove the stuffing from meat or poultry and store it separately.
- Date packages of leftovers and use within a safe period of time.
- Cover and reheat leftovers thoroughly before serving.
- Bring sauces, soups and gravy to a boil. Heat other foods to 165°F (75°C).
- If you think food may be spoiled, discard it. When in doubt, throw it out.

Fresh Food Storage

Shelf life of fresh foods varies depending on how fresh it is when you buy it. To keep your food fresher longer, follow the recommended storage tips.

Vegetables: Wash vegetables in cool water and drain. Store in airtight containers or plastic wrap. Vegetables stay fresh longer in high humidity storage.

Fruits: Wash and dry fresh fruits. Store more aromatic fruits in plastic bags. Most fruits stay fresh longer in low humidity storage.

Prepackaged meats: Store in original packaging. After opening, rewrap tightly in plastic wrap or aluminum foil.

Eggs: Store eggs unwashed in their carton or a portable egg tray. Use within three weeks.

Milk, cream and cottage cheese: Keep carton closed. Store on refrigerator shelf and use within 1–2 weeks.

Cheese: Store in original packaging until ready to use. After opening, rewrap tightly in plastic wrap or aluminum foil.

Leftovers: Let cool and cover tightly with plastic wrap or foil. Airtight plastic containers work well to prevent drying out and odor transfer.

ETHYLENE

Some fruits and vegetables will produce ethylene, a gas that initiates the ripening process. Ethylene can cause premature ripening in some foods, while in others, it can actually cause damage. To reduce unnecessary spoilage of your fresh produce, do not store ethylene producing fruits and vegetables with those that are ethylene sensitive. Refer to the chart on page 29.

Frozen Food Storage

Freezer storage: Wrap foods in material designed for frozen food storage. The wrap must seal out air and moisture. Do not refreeze thawed meats.

Ice cream: The firmness of the ice cream will depend on its cream content. Higher quality ice creams usually have a higher cream content, requiring colder freezer temperatures to maintain their firmness. Soft ice cream is not always an indication of a temperature problem.

Make sure your refrigerator and freezer doors close freely and completely. Overloading will affect temperatures inside the unit. Do not fill your freezer with large quantities of unfrozen foods expecting them to fast freeze. Give the freezer ample time to circulate cold air around unfrozen items before adding additional items.

SUGGESTED FOOD STORAGE

The food storage charts on the following pages give you specific information to help you keep food safe and keep it at its best quality. The recommended storage temperatures will help you determine optimal storage conditions for your food. As a general rule, food that is handled properly and kept at temperatures below 40°F (4°C) will be safe to eat.

Storing food at temperatures below 40°F (4°C) keeps it out of the danger zone. The storage times for refrigeration will help keep food from spoiling or becoming dangerous to eat. The time limits for frozen foods are to maintain flavor and texture. Food kept frozen longer than the recommended time will still be safe to eat, but its quality may diminish.

Fish, Meats and Poultry

	Recommended Temperature	Storage Life (refrigerator)	Storage Life (freezer)*	Comments
FRESH FISH AND SEAFOOD				
cod, flounder, haddock	34°F (1°C)	2 days	6 months	Freeze in original wrap up to 2 weeks. Use freezer wrap, freezer-quality plastic bags or aluminum foil over the commercial wrap if foods will be frozen for more than a couple of months.
sole bluefish, perch	34°F (1°C)	2 days	2–3 months	
mackerel, salmon	34°F (1°C)	4 days	5–9 months	
shrimp, oysters	34°F (1°C)	1 day	6 months	
FRESH MEAT				
beef steaks, roasts	34–35°F (1–2°C)	3–5 days	6–12 months	Freeze in original wrap up to 2 weeks. Use freezer wrap, freezer-quality plastic bags or aluminum foil over the commercial wrap if foods will be frozen for more than a couple of months.
lamb chops, roasts	34–35°F (1–2°C)	3–5 days	6–9 months	
pork and veal chops, roasts	34–35°F (1–2°C)	3–5 days	4–6 months	
variety meats (tongue, liver, etc.)	34–35°F (1–2°C)	1–2 days	3–4 months	
HAMBURGER, GROUND AND STEW MEATS				
hamburger, stew meats, ground turkey, veal, pork, lamb and mixtures	34–35°F (1–2°C)	1–2 days	3–4 months	Freeze in original wrap up to 2 weeks. Use freezer wrap, freezer-quality plastic bags or aluminum foil over the commercial wrap if foods will be frozen for more than a couple of months.
HOTDOGS AND LUNCH MEATS				
hotdogs (opened package)	34–35°F (1–2°C)	1 week	1–2 months	Freeze in freezer wrap. Check 'sell by' dates. Do not use more than 1 week after this date.
hotdogs (unopened package)	34–35°F (1–2°C)	2 weeks	1–2 months	
lunch meats (opened package)	34–35°F (1–2°C)	3–5 days	1–2 months	
lunch meats (unopened package)	34–35°F (1–2°C)	2 weeks	1–2 months	
BACON AND SAUSAGE				
bacon	34–35°F (1–2°C)	7 days	1 month	Keep wrapped, and store at recommended refrigerator temperatures.
raw sausage (pork, beef, turkey)	34–35°F (1–2°C)	1–2 days	1–2 months	
smoked breakfast links or patties	34–35°F (1–2°C)	7 days	1–2 months	
hard sausage (pepperoni, jerky sticks)	34–35°F (1–2°C)	2–3 weeks	1–2 months	
HAM AND CORNED BEEF				
corned beef	34–35°F (1–2°C)	5–7 days	1 month	For freezer storage, drain juices.
ham, whole	34–35°F (1–2°C)	7 days	1–2 months	
ham, half	34–35°F (1–2°C)	3–5 days	1–2 months	
ham, slices	34–35°F (1–2°C)	3–4 days	1–2 months	
FRESH POULTRY				
chicken or turkey, whole	34–35°F (1–2°C)	1–2 days	12 months	Freeze in original wrap up to 2 weeks. Use freezer wrap, freezer-quality plastic bags or aluminum foil over the commercial wrap if foods will be frozen for more than a couple of months.
chicken or turkey, pieces	34–35°F (1–2°C)	1–2 days	9 months	
duck or goose	34–35°F (1–2°C)	1–2 days	6 months	

*Recommended freezer storage temperature is 0°F (-18°C).

Fresh Vegetables

	Recommended Temperature	Storage Life (refrigerator)	Comments	
FRESH VEGETABLES				
anise	34–36°F (1–2°C)	2–3 weeks	Wash vegetables in cool water and drain. Store in airtight container or plastic wrap.	
artichokes	34°F (1°C)	1–2 weeks		
asparagus	34–36°F (1–2°C)	2–3 weeks	Most vegetables should be stored in higher humidity.	
beans, green/snap/lima*	40–45°F (4–7°C)	7–10 days		
bean sprouts	34°F (1°C)	7–9 days		
beets	34°F (1°C)	3–4 months		
belgian endive	36–38°F (2–3°C)	2–4 weeks		
bok choy	34°F (1°C)	3 weeks		
broccoli	34°F (1°C)	1–2 weeks		Discard any fresh vegetables that are moldy or have other signs of spoilage and wipe out the refrigerator compartment.
brussels sprouts	34°F (1°C)	3–5 weeks		
cabbage	34°F (1°C)	3–6 weeks	For fresh-cut produce, follow storage directions on package.	
carrots	34°F (1°C)	1–5 months		
cauliflower	34°F (1°C)	3–4 weeks		
celeriac	34°F (1°C)	6–8 months		
celery	34°F (1°C)	1–2 months		
chinese broccoli	34°F (1°C)	10–14 days		
chinese cabbage	34°F (1°C)	2–3 months		Refer to the list of ethylene sensitive and ethylene producing vegetables and fruits.
corn, sweet	34°F (1°C)	5–8 days		
cucumbers*	45°F (7°C)	10–14 days		
daikon	34°F (1°C)	4 months		
eggplant*	45°F (7°C)	1–2 weeks		
endive/escarole	34°F (1°C)	2–3 weeks		
garlic	34°F (1°C)	6–7 months		
horseradish	34°F (1°C)	10–12 months		
jerusalem artichokes	34°F (1°C)	1–2 weeks		
kale	34°F (1°C)	1–2 months		
kohlrabi	34°F (1°C)	10–14 days		
leeks	34°F (1°C)	2 months		
lettuce	34°F (1°C)	2–3 weeks		
mushrooms	34°F (1°C)	1–2 weeks		
okra*	45°F (7°C)	1–2 weeks		
onions, bulb	34°F (1°C)	1–6 months		
onions, green	34°F (1°C)	7–10 days		
parsley	34°F (1°C)	1–2 months		
parsnips	34°F (1°C)	4–5 months		
peas, pods and shelled	34°F (1°C)	1–2 weeks		
peppers, bell*	45°F (7°C)	2–3 weeks		
peppers, chile	45°F (7°C)	2–3 weeks		
pumpkins*	38–45°F (3–7°C)	3–4 months		
radicchio	34°F (1°C)	2–3 weeks		

*Sensitive to chill injury, a cause of spoilage. Damage may not be apparent until the vegetable is returned to a warmer temperature. See food preservation guide for complete instructions on freezing vegetables. Recommended freezer storage temperature is 0°F (-18°C).

Fresh Vegetables

	Recommended Temperature	Storage Life (refrigerator)	Comments
FRESH VEGETABLES			
radishes	34°F (1°C)	1–2 months	Wash vegetables in cool water and drain. Store in airtight container or plastic wrap.
romaine	34°F (1°C)	2–3 weeks	
rutabagas	34°F (1°C)	4–6 months	Most vegetables should be stored in higher humidity.
salsify	34°F (1°C)	2–4 months	
shallots	34°F (1°C)	6 months	
snow peas	34°F (1°C)	1–2 weeks	
spinach	34°F (1°C)	10–14 days	
squash, summer*	40–45°F (4–7°C)	1–2 weeks	
<hr/>			
tamarillos	37–40°F (3–4°C)	10 weeks	Discard any fresh vegetables that are moldy or have other signs of spoilage and wipe out the refrigerator compartment.
tomatoes (ripe)	46–50°F (8–10°C)	1–3 weeks	
turnips	34°F (1°C)	4–5 months	For fresh-cut produce, follow storage directions on package.
water chestnuts	34–36°F (1–2°C)	2–4 months	
watercress	34°F (1°C)	2–3 weeks	Refer to the list of ethylene sensitive and ethylene producing vegetables and fruits.

*Sensitive to chill injury, a cause of spoilage. Damage may not be apparent until the vegetable is returned to a warmer temperature.

See food preservation guide for complete instructions on freezing vegetables. Recommended freezer storage temperature is 0°F (-18°C).

Fresh Fruits

	Recommended Temperature	Storage Life (refrigerator)	Comments
FRESH FRUITS			
apples* (macintosh, grimes golden, yellow newtown)	34–40°F (1–4°C)	1–2 months	Wash and dry most fruits, and store in the crisper compartment. (Do not wash berries and cherries until you are ready to use them, however.)
apples	30°F (-1°C)	3–6 months	
apricots	34°F (1°C)	1–2 weeks	Most fruits should be stored in lower humidity.
asian pears	34°F (1°C)	5–6 months	
avocados*	40°F (4°C)	2–4 weeks	
blackberries	34°F (1°C)	2–3 days	
blood oranges	40–44°F (4–7°C)	3–8 weeks	
blueberries	34°F (1°C)	10–18 days	
cantaloupe*	36–41°F (2–5°C)	2–3 weeks	
cassavas	34°F (1°C)	1–2 months	
cherries, sweet	34°F (1°C)	2–3 weeks	
clementines	40°F (4°C)	2–4 weeks	
cranberries*	36–40°F (2–4°C)	2–4 months	Fully ripe fruits should be stored in the refrigerator at recommended temperatures to slow down the ripening process. To hasten the ripening process, you can place unripe fruit in a paper bag that has holes poked in it. Close the bag and set it on a counter. The fruit will produce ethylene, a gas that initiates the ripening process. Check the bag each day.
figs, fresh	34°F (1°C)	7–10 days	
grapes	34°F (1°C)	2–3 weeks	
guavas*	40–45°F (4–7°C)	2–3 weeks	
honeydew	45°F (7°C)	3–4 weeks	
kiwifruit	34°F (1°C)	4–6 weeks	
kumquats	40°F (4°C)	2–4 weeks	
lychees	35°F (2°C)	3–5 weeks	
nectarines	34°F (1°C)	2–4 weeks	Discard any fresh fruits that are moldy or have other signs of spoilage and wipe out the refrigerator compartment. Refer to the list of ethylene sensitive and ethylene producing vegetables and fruits.
oranges*	34–45°F (1–7°C)	3–8 weeks	
papayas*	45°F (7°C)	1–3 weeks	
peaches	34°F (1°C)	2–4 weeks	
pears	34°F (1°C)	2–3 weeks	
persimmons	34°F (1°C)	3–4 months	
pineapple*	45°F (7°C)	2–4 weeks	
plums and prunes	34°F (1°C)	2–5 weeks	
pomegranates*	40°F (4°C)	2–3 months	
quinces	34°F (1°C)	2–3 months	
raspberries	34°F (1°C)	3–6 days	
rhubarb	34°F (1°C)	2–3 weeks	
strawberries	34°F (1°C)	7–10 days	
tangerines	40°F (4°C)	2–4 weeks	
watermelon*	45°F (7°C)	2–3 weeks	

*Sensitive to chill injury, a cause of spoilage. Damage may not be apparent until the fruit is returned to a warmer temperature.

See food preservation guide for complete instructions on freezing fruits. Recommended freezer storage temperature is 0°F (-18°C).

Ethylene Gas

ETHYLENE PRODUCING FOODS

apples	cherimoyas	mamey sapote	passion fruit	plums
apricots	figs	mangoes	peaches	prunes
avocados	guavas	mangosteen	pears	quince
ripening bananas	honeydew	nectarines	persimmons	tomatoes
cantaloupe	kiwifruit	papayas	plantains	

ETHYLENE SENSITIVE FOODS

unripe bananas	cabbage	eggplant	peas	watercress
green beans	carrots	unripe kiwifruit	peppers	watermelon
belgian endive	cauliflower	leafy greens	spinach	
broccoli	chard	lettuce	squash	
brussels sprouts	cucumbers	okra	sweet potatoes	

IMPORTANT NOTE: Do not store ethylene producing foods with ethylene sensitive foods.

Deli Foods, Dairy Products and Other Foods

	Recommended Temperature	Storage Life (refrigerator)	Storage Life (freezer)*	Comments
DELI FOODS				
thinly sliced lunch meats	34–35°F (1–2°C)	1–2 days	NR	Check 'use by' or 'sell by' dates. These foods do not freeze well. If you need to freeze, do so immediately, not after they have been held in the refrigerator.
egg, chicken, tuna and ham salads	34–35°F (1–2°C)	3–5 days	NR	
macaroni salads	34–35°F (1–2°C)	3–5 days	NR	
pre-stuffed chops, chicken breasts	34–35°F (1–2°C)	1 day	NR	
store-prepared convenience meals	34–35°F (1–2°C)	1–2 days	NR	
DAIRY FOODS				
butter	34–35°F (1–2°C)	3 months	1 year	Check 'sell by' dates.
cottage or ricotta cheese	34–35°F (1–2°C)	1–2 weeks	4 weeks	
cream cheese	34–35°F (1–2°C)	2 weeks		Store cheese in original packaging until ready to use. After opening, rewrap tightly in plastic wrap or aluminum foil.
natural cheese (cheddar, brick, etc.)	34–35°F (1–2°C)	3–6 months	6–8 months	
process cheese	34–35°F (1–2°C)	3–4 weeks	6–8 months	
grated Parmesan or Romano	34–35°F (1–2°C)	1 year		
yogurt	34–35°F (1–2°C)	1 month		
whole, lowfat or skim milk	34–35°F (1–2°C)	1–2 weeks		Thaw frozen cheese in the refrigerator to reduce crumbling.
EGGS				
fresh, in shell	34°F (1°C)	3 weeks	NR	Keep fresh eggs refrigerated.
hard cooked	34–35°F (1–2°C)	1 week	NR	
liquid pasteurized or egg substitutes				Do not eat hard cooked eggs that have been at room temperature for more than 2 hours.
opened	34–35°F (1–2°C)	3 days	NR	
unopened	34–35°F (1–2°C)	10 days	1 year	
COOKED MEAT AND POULTRY LEFTOVERS				
cooked meat and meat dishes	34–35°F (1–2°C)	3–4 days	2–3 months	Refrigerate or freeze leftovers in covered shallow containers within 2 hours after cooking. Reheat leftovers to 165°F (74°C).
gravy and meat broth	34–35°F (1–2°C)	1–2 days	2–3 months	
fried or plain chicken, pieces	34–35°F (1–2°C)	3–4 days	4 months	
cooked poultry dishes	34–35°F (1–2°C)	3–4 days	4–6 months	
pieces covered with broth, gravy	34–35°F (1–2°C)	1–2 days	6 months	
chicken nuggets, patties	34–35°F (1–2°C)	1–2 days	1–3 months	
SOUPS AND STEWS				
vegetable	34–35°F (1–2°C)	3–4 days	2–3 months	Reheat to at least 165°F (74°C) before serving.
meat added	34–35°F (1–2°C)	3–4 days	2–3 months	

*Recommended freezer storage temperature is 0°F (-18°C). (NR) stands for not recommended for freezing.

Frequently Asked Questions

ICE PRODUCTION

IMPORTANT NOTE: Make sure that the ice maker system is on. If it is, the word ICE will be illuminated in the control panel display.

IMPORTANT NOTE: The first container filled with ice should be discarded, as with any new connection there may be impurities in the ice from the water supply line.

Q: My ice maker isn't producing very much ice.

A: On average, you can expect a cycle of ice (eight cubes per cycle) every two hours.

Q: The ice is freezing together and clumping.

A: If ice is not used regularly it tends to fuse together. You may need to discard the ice and allow ice to be replenished. Some types of filter systems or incorrect water pressure issues may cause this condition.

Q: The ice tastes funny and is discolored.

A: Sub-Zero integrated models do not have an integrated water filtration system. Contact a local plumber to discuss water filtration options.

NOISE

Q: Why do I hear my unit running constantly?

A: It is normal to hear the operation of fans and compressors. Sounds will be accentuated based on the placement of the unit and overall room design.

TEMPERATURE

IMPORTANT NOTE: Unless the unit is being serviced, make sure the power for your unit is on.

Q: How do I adjust the temperatures?

A: To adjust temperatures, refer to temperature control on page 10.

Q: What are the suggested temperature settings?

A: The recommended settings are 38°F (3°C) for refrigerator zones and 0°F (-18°C) for freezer zones.

Q: Condensation is forming on the inside and outside of my unit.

A: In climates with higher humidity, condensation will form and is considered normal. Leaving the door open for a long period of time may also contribute to condensation forming on the inside your unit.

Q: My unit isn't cooling properly.

A: Clean the condenser area as outlined on page 19.

DOOR OPERATION

Q: Why is my door hard to open?

A: Your unit was designed for an airtight seal. A vacuum seal can form after the door is closed. Wait several seconds for pressure to equalize before reopening the door.

Q: The door on my unit is opening too fast and hitting the wall or surrounding cabinets.

A: The unit may not be leveled properly or a door stop may be required. To adjust the built-in door stop, refer to 90° door stop on page 20.

Troubleshooting

If your integrated unit is not operating properly, use the following troubleshooting guide before calling Sub-Zero factory certified service. This guide will save you time and trouble and may help you avoid the expense of a service call.

'SERVICE' flashes in the control panel display.

- This may indicate that the condenser needs cleaning. See condenser cleaning on page 19.
- Turn the unit off with the UNIT ON/OFF key pad (POWER for column models), then restart by pressing the key pad again. If 'SERVICE' flashes again, contact Sub-Zero factory certified service.

'SERVICE' and 'ICE' flash in the control panel display.

- Turn the unit off with the UNIT ON/OFF key pad (POWER for column models), then restart by pressing the key pad again. If 'SERVICE' and 'ICE' flash again, contact Sub-Zero factory certified service.

Refrigerator/freezer is not operating.

- Is there electrical power to the unit?
- Is the refrigerator/freezer control on?
- Is the home circuit breaker or fuse off?
- Is the condenser area clean?
- Is the unit in showroom mode? Call Sub-Zero customer care at 800-222-7820 for assistance in determining if the unit is in showroom mode.
- If the unit is still not running, it may be in defrost mode. Wait 30 minutes to see if the unit will restart.

Refrigerator/freezer is warmer than usual.

- Is the control set properly?
- Is the condenser area clean?
- Has the door or a drawer been left open for an extended period? Be sure that food is not obstructing proper door or drawer closing.
- Has a large amount of food been added recently?

Refrigerator/freezer runs for long periods of time.

- Is the condenser area clean?
- Has the door or a drawer been left open for an extended period? Be sure that food is not obstructing proper door or drawer closing.
- Has a large amount of food been added recently?
- On hot days and in warm room temperatures, the compressor runs longer.

Refrigerator/freezer is frosted up.

- Has the door or a drawer been left open for an extended period? Be sure that food is not obstructing proper door or drawer closing.
- Are the door and drawers closing and sealing properly?

Troubleshooting

Condensation forms inside the unit.

- This is normal during periods of higher humidity and with frequent door openings.
- Are the door and drawers closing and sealing properly?

Condensation forms outside the unit.

- During periods of high humidity, some condensation may appear on the outside of the unit. The condensation will disappear when the humidity drops. Be sure that the door and drawers are closing and sealing properly. If condensation persists, contact Sub-Zero factory certified service.

Ice maker is not working.

- Does the unit have an ice maker installed?
- Is the ice maker system turned on at the control panel?
- Is the ice container in the correct position within the freezer drawer compartment?
- Is the water supply for the ice maker connected and operating properly?

Ice is clumping in the ice container.

- Is the ice being used frequently? Discard and allow ice to be replenished.

Light bulb needs to be replaced.

- See lighting information on page 17.

⚠ WARNING

Shut off power to the unit at the circuit breaker before replacing light bulbs. Wear protective gloves when handling bulbs.

Storage drawer is hard to close.

- Is the unit leveled properly?
- Be sure that there are no food or packaging items that interfere with the ice maker or other interior components.
- Drawer slides in a freezer compartment may not move as freely as in a refrigerator compartment due to lower temperatures.

There is an odor inside the unit.

- Clean the unit thoroughly.
- Cover all food tightly.

You need product information.

- Call Sub-Zero customer care at 800-222-7820 or visit our website, subzero.com, for planning, installation and product information.

You need service.

- If service is necessary, maintain the quality built into your Sub-Zero unit by contacting Sub-Zero factory certified service.
- For the name of Sub-Zero factory certified service nearest you, check the contact & support section of our website, subzero.com or call Sub-Zero customer care at 800-222-7820.
- When calling for service, you will need the model and serial number of your unit. Both numbers are listed on the product rating plate. Refer to pages 5–9 for location of the rating plate for your specific model.

Service Information

This use & care guide gives you the tools necessary to preserve food at optimum quality in your integrated unit. Keep the door and drawers closed as much as possible whenever the unit is operating.

If you do need service, be sure to have the model and serial number of your unit when you call. The numbers are listed on the product rating plate. For column models, the rating plate is located inside the top drawer near the drawer guide opposite the hinge. For tall and drawer models, the rating plate is located inside the cabinet, to the left of the upper drawer. Refer to pages 5–9 for location of the rating plate for your specific model.

For warranty purposes, you will also need the date of installation and the name of your authorized Sub-Zero dealer. Record this information below for future reference.

Model Number _____

Serial Number _____

Installation Date _____

Sub-Zero Factory Certified Service

Phone _____

Authorized Sub-Zero Dealer

Phone _____

BEFORE CALLING FOR SERVICE

Before calling Sub-Zero factory certified service, refer to the troubleshooting guide on pages 31–33. Check the household fuse or circuit breaker to see if it has been blown or tripped and that the electrical connection to the appliance has not been disconnected. A power outage may also have caused a disruption in service.

PRODUCT REGISTRATION

Register your new Sub-Zero today so that we may ensure your satisfaction. You may register by one of the following options:

- 1) Mail in the completed Sub-Zero product registration card.
- 2) Register online at subzero.com.
- 3) Register by phone by calling Sub-Zero customer care at 800-222-7820.

The model and serial number of your unit are printed on the enclosed Sub-Zero product registration card. If you provide us with your e-mail address, we will send you exciting new product updates and recipes as they become available, along with information on special events.

The information and images in this guide are the copyright property of Sub-Zero, Inc. Neither this guide nor any information or images contained herein may be copied or used in whole or in part without the express written permission of Sub-Zero, Inc. ©Sub-Zero, Inc. all rights reserved.

Wolf, Wolf & Design, Wolf Gourmet, W & Design and the color red as applied to knobs are registered trademarks and service marks of Wolf Appliance, Inc. Sub-Zero, Sub-Zero & Design, Dual Refrigeration, Constant Care and The Living Kitchen are registered trademarks and service marks of Sub-Zero, Inc. (collectively, the "Company Marks.") All other trademarks or registered trademarks are property of their respective owners in the United States and other countries.

Sub-Zero Products Limited Warranty

FOR RESIDENTIAL USE ONLY

FULL TWO YEAR WARRANTY*

For two years from the date of original installation, your Sub-Zero product warranty covers all parts and labor to repair or replace, under normal residential use, any part of the product that proves to be defective in materials or workmanship. All service provided by Sub-Zero under the above warranty must be performed by Sub-Zero factory certified service, unless otherwise specified by Sub-Zero, Inc. Service will be provided during normal business hours.

FULL FIVE YEAR SEALED SYSTEM WARRANTY

For five years from the date of original installation, your Sub-Zero product warranty covers all parts and labor to repair or replace, under normal residential use, the compressor, condenser, evaporator, drier and all connecting tubing that prove to be defective in materials or workmanship. All service provided by Sub-Zero under the above warranty must be performed by Sub-Zero factory certified service, unless otherwise specified by Sub-Zero, Inc. Service will be provided during normal business hours.

LIMITED TWELVE YEAR SEALED SYSTEM WARRANTY

For twelve years from the date of original installation, your Sub-Zero product warranty covers all parts to repair or replace, under normal residential use, the compressor, condenser, evaporator, drier and all connecting tubing that prove to be defective in materials or workmanship.

TERMS APPLICABLE TO EACH WARRANTY

The warranty applies only to products installed for normal residential use. The warranty applies only to products installed in any one of the fifty states of the United States, the District of Columbia or the ten provinces of Canada. This warranty does not cover any parts or labor to correct any defect caused by negligence, accident or improper use, maintenance, installation, service or repair.

THE REMEDIES DESCRIBED ABOVE FOR EACH WARRANTY ARE THE ONLY ONES THAT SUB-ZERO, INC. WILL PROVIDE, EITHER UNDER THIS WARRANTY OR UNDER ANY WARRANTY ARISING BY OPERATION OF LAW. SUB-ZERO, INC. WILL NOT BE RESPONSIBLE FOR ANY CONSEQUENTIAL OR INCIDENTAL DAMAGES ARISING FROM THE BREACH OF THIS WARRANTY OR ANY OTHER WARRANTY, WHETHER EXPRESS, IMPLIED OR STATUTORY.

Some states do not allow the exclusion or limitation of incidental or consequential damages, so the above limitation or exclusion may not apply to you. This warranty gives you specific legal rights and you may also have other legal rights that vary from state to state.

To receive parts and/or service and the name of Sub-Zero factory certified service nearest you, contact Sub-Zero, Inc., P.O. Box 44848, Madison, WI 53744; check the contact & support section of our website, subzero.com or call 800-222-7820.

*Stainless steel doors, panels, handles, product frames and interior surfaces are covered by a limited 60-day parts and labor warranty for cosmetic defects.

*Replacement water filters and air purification cartridges are not covered by the product warranty.





SUB-ZERO, INC. P. O. BOX 44848 MADISON, WI 53744 SUBZERO.COM 800.222.7820

7020105 REV-A

5/2011

