

HOLE PATTERN FOR TABLE MOUNTING
VIEWED FROM ABOVE

INSTRUCTIONS FOR SCREW DOWN TABLE TOP MOUNTING:

LOCATE WHERE TV IS TO BE INSTALLED.
 NOTE CENTER POSITION OF TV. SCREW HOLES WILL BE SYMMETRICAL ABOUT CENTER OF TV
 MARK 4 SCREW LOCATIONS AT THE DIMENSIONS SHOWN IN THE SKETCH.
 DRILL 4 1/8 INCH DIAMETER HOLES AT THESE LOCATIONS
 INSTALL 4 #10 X 1 INCH SCREWS INTO HOLES. TIGHTEN UNTIL HEAD IS 1/4 INCH ABOVE TABLE TOP SURFACE.
 INSTALL TV ONTO SCREWS BY LOWERING THE REAR KEYHOLE CUTOUTS OVER THE REAR SCREWS AND THEN HOOKING THE FRONT U-SHAPED HOLE OVER THE HEAD OF THE FRONT SCREWS AND THEN SLIDING THE TV TOWARDS THE REAR TO LOCK IN PLACE.
 TIGHTEN THE REAR SCREWS TO HOLD THE TV IN PLACE.

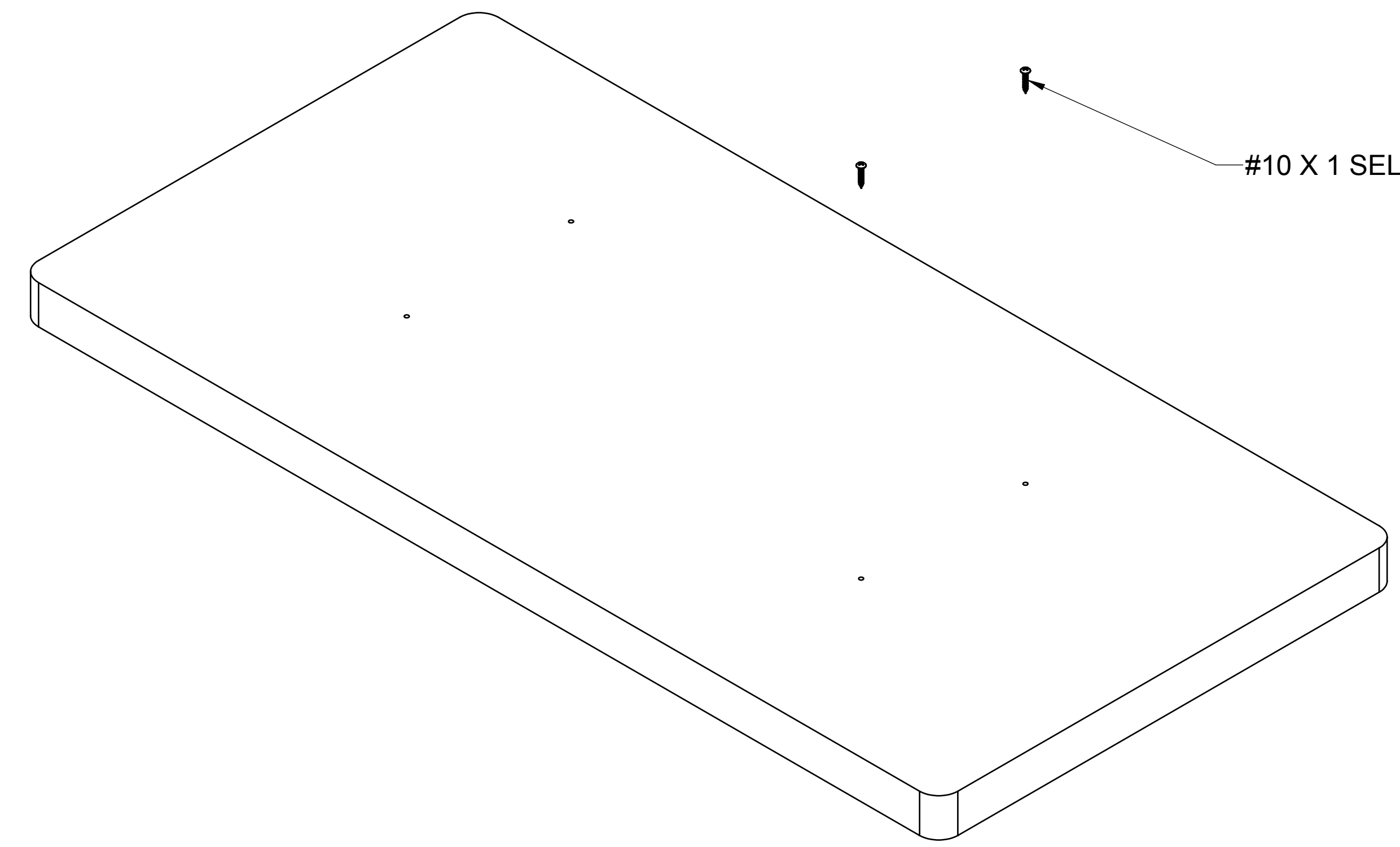

#10 X 1 SELF TAPPING SCREWS, 4X

TOLERANCES AND DIMENSIONING BEFORE PLATING UNLESS OTHERWISE SPECIFIED: DIMS INCHES mm X.X ±0.04 ±1.5 X.XX ±0.03 ±0.5 X.XXX ±0.015 ±0.1 X.XXX ±0.005 FRACTIONAL: ±0.03 ANGLE ±1/2° (BUT NOT OVER 0.03) HOLES ≤ φ .500 +0.003/-0.001 HOLES > φ .500 +0.005/-0.001 LOCATE φ TO ±0.015 (C) CONCENTRICITY 0.003 TIR REMOVE BURRS AND BREAK SHARP EDGES	FINISH:	PROPRIETARY AND CONFIDENTIAL THE INFORMATION CONTAINED IN THIS DRAWING IS THE SOLE PROPERTY OF SUNBRITEV LLC. ANY REPRODUCTION IN PART OR AS A WHOLE WITHOUT THE WRITTEN PERMISSION OF SUNBRITEV LLC IS PROHIBITED.	
	DRAWN TRW	TITLE:	
	CHECKED TRW	09112501_sb4630 tech drawings	
	ENG APPR. TRW	SCALE: 1:7	DO NOT SCALE DRAWING
DATE:		SHEET 1 OF 7	REV

09112501_sb4630 tech drawings



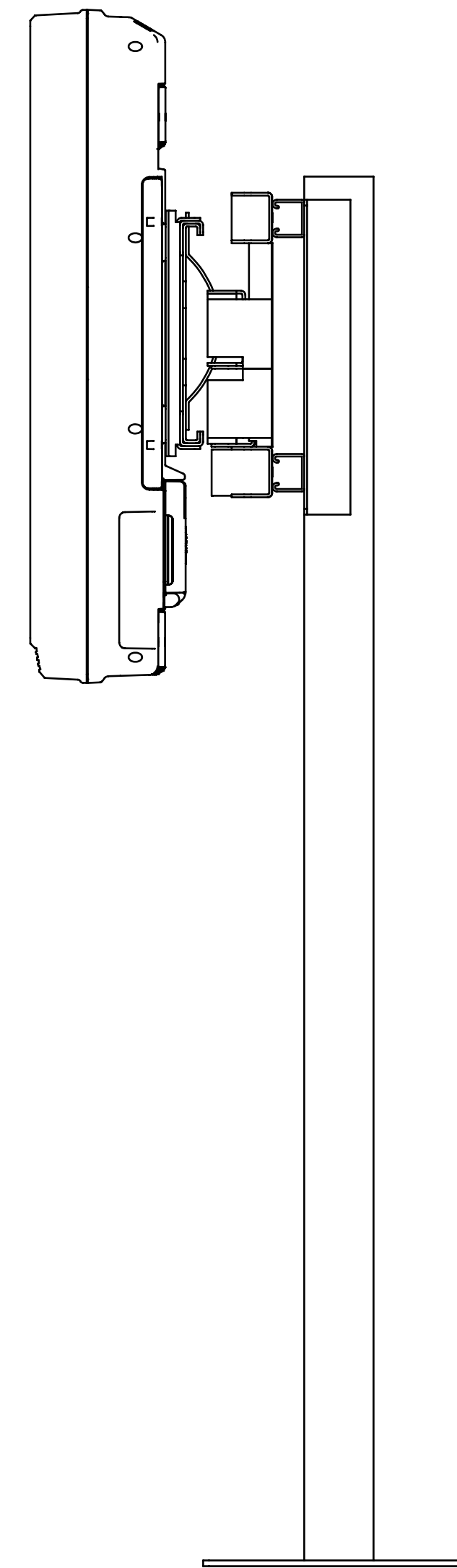
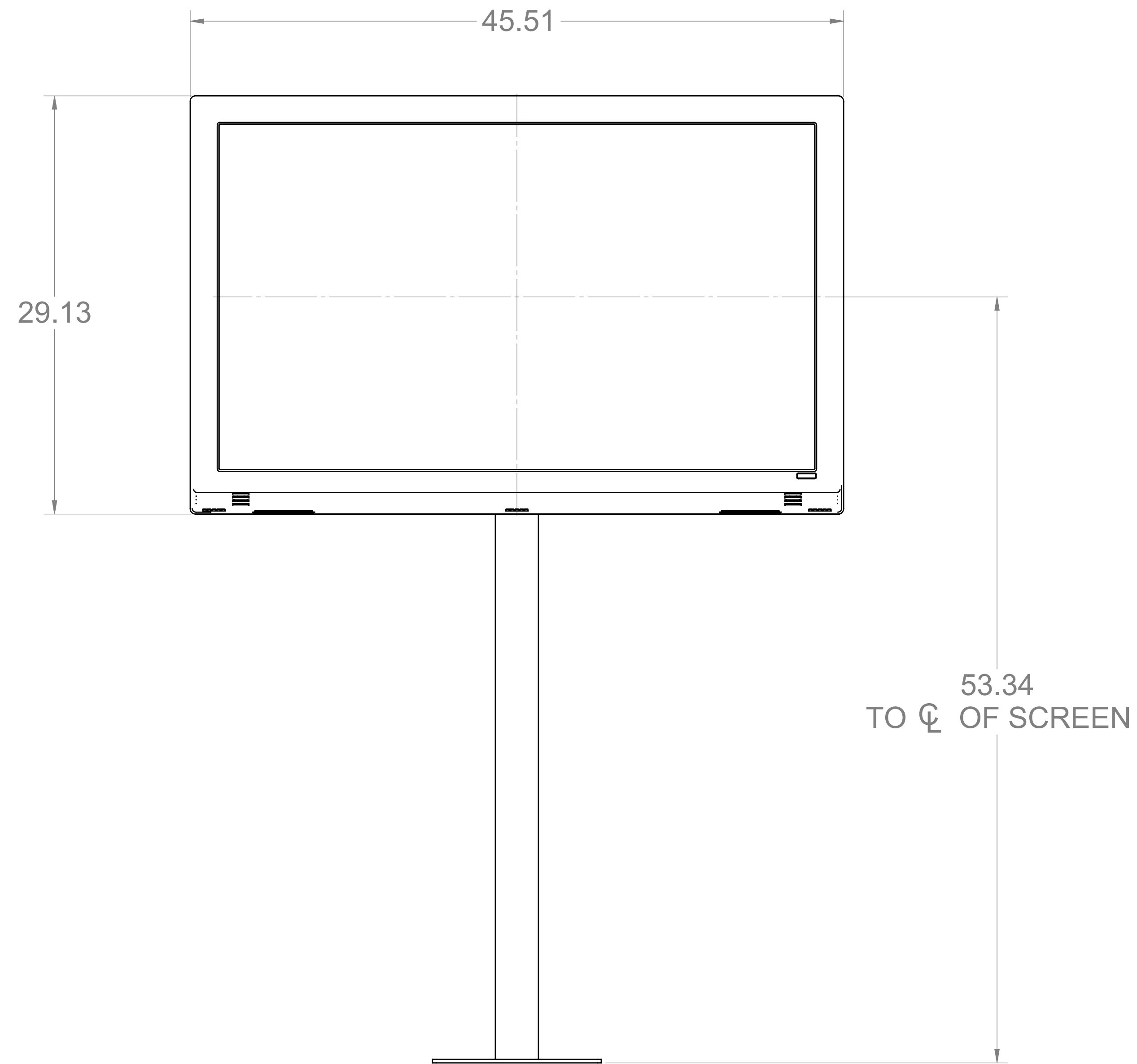
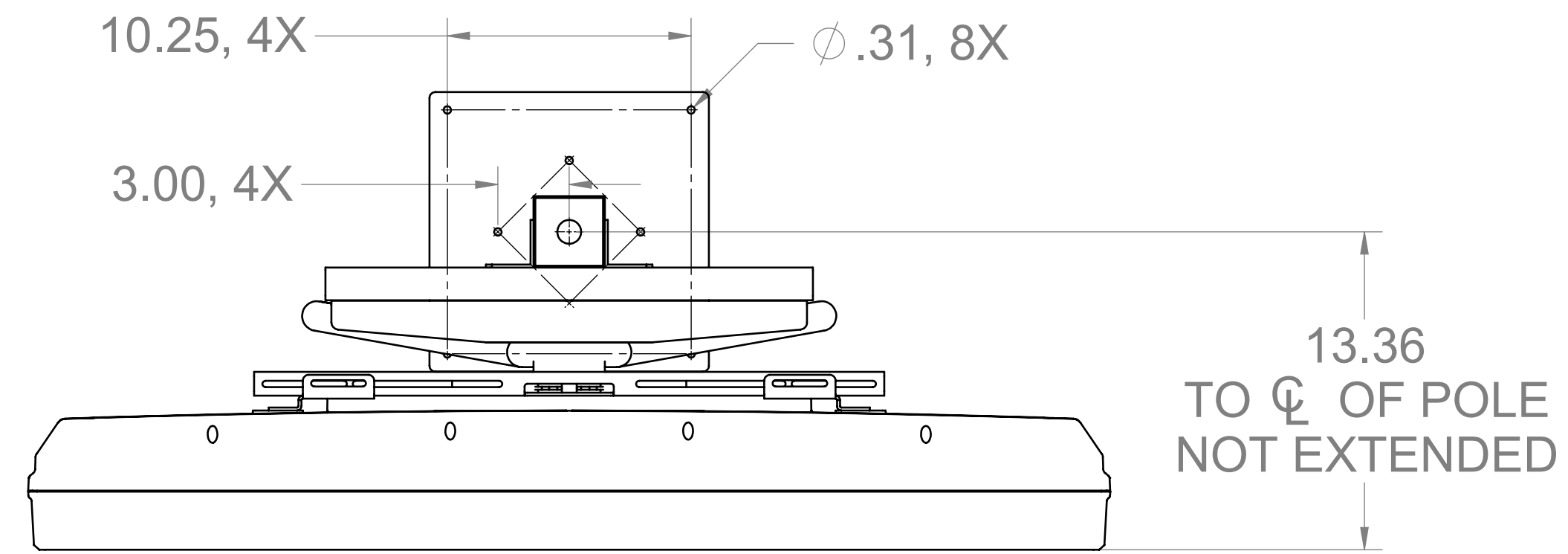

DIMS INCHES mm X ±0.04 ±1 X.X ±0.03 ±0.5 X.XX ±0.015 ±0.1 X.XXX ±0.005 FRACTIONAL: ±0.03 ANGLE ±1/2° (BUT NOT OVER 0.03) HOLES ≤ φ .500 +0.003/-0.001 HOLES > φ .500 +0.005/-0.001 LOCATE φ TO ±0.015 (C) CONCENTRICITY 0.003 TIR REMOVE BURRS AND BREAK SHARP EDGES	FINISH:	PROPRIETARY AND CONFIDENTIAL THE INFORMATION CONTAINED IN THIS DRAWING IS THE SOLE PROPERTY OF SUNBRITE TV LLC. ANY REPRODUCTION IN PART OR AS A WHOLE WITHOUT THE WRITTEN PERMISSION OF SUNBRITE TV LLC IS PROHIBITED.		
	DRAWN TRW	TITLE: 09112501_sb4630 tech drawings		
	CHECKED TRW	SCALE: 1:6	DO NOT SCALE DRAWING	DWG. NO.
	ENG APPR. TRW	DATE:	SHEET 2 OF 7	REV

09112501_sb4630 tech drawings



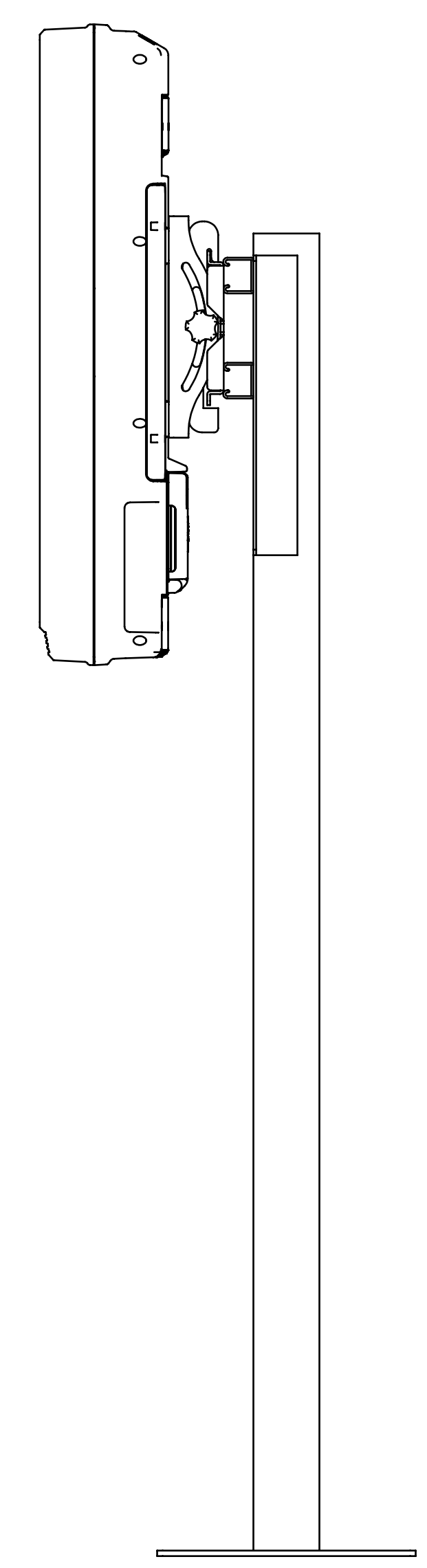
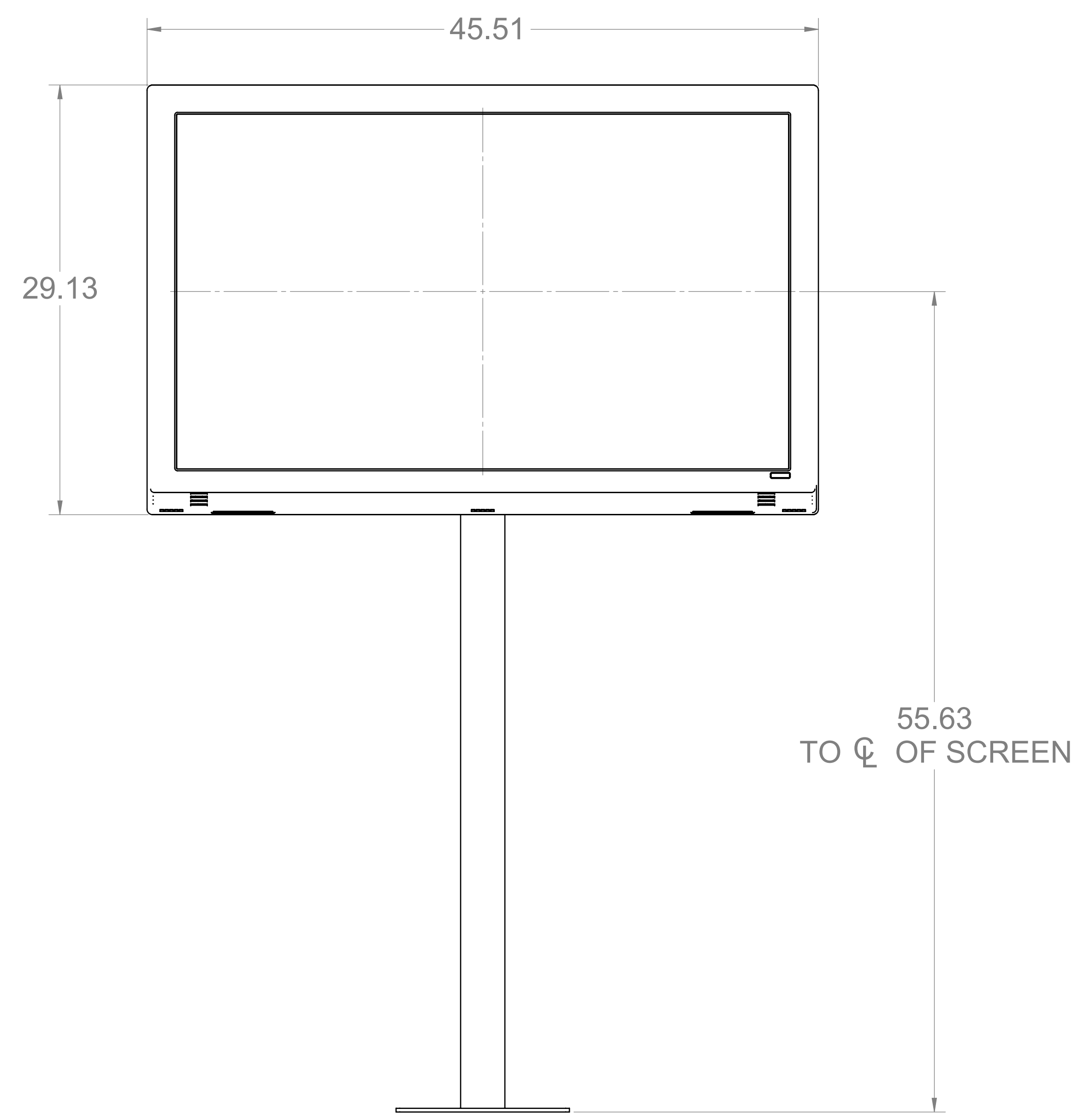
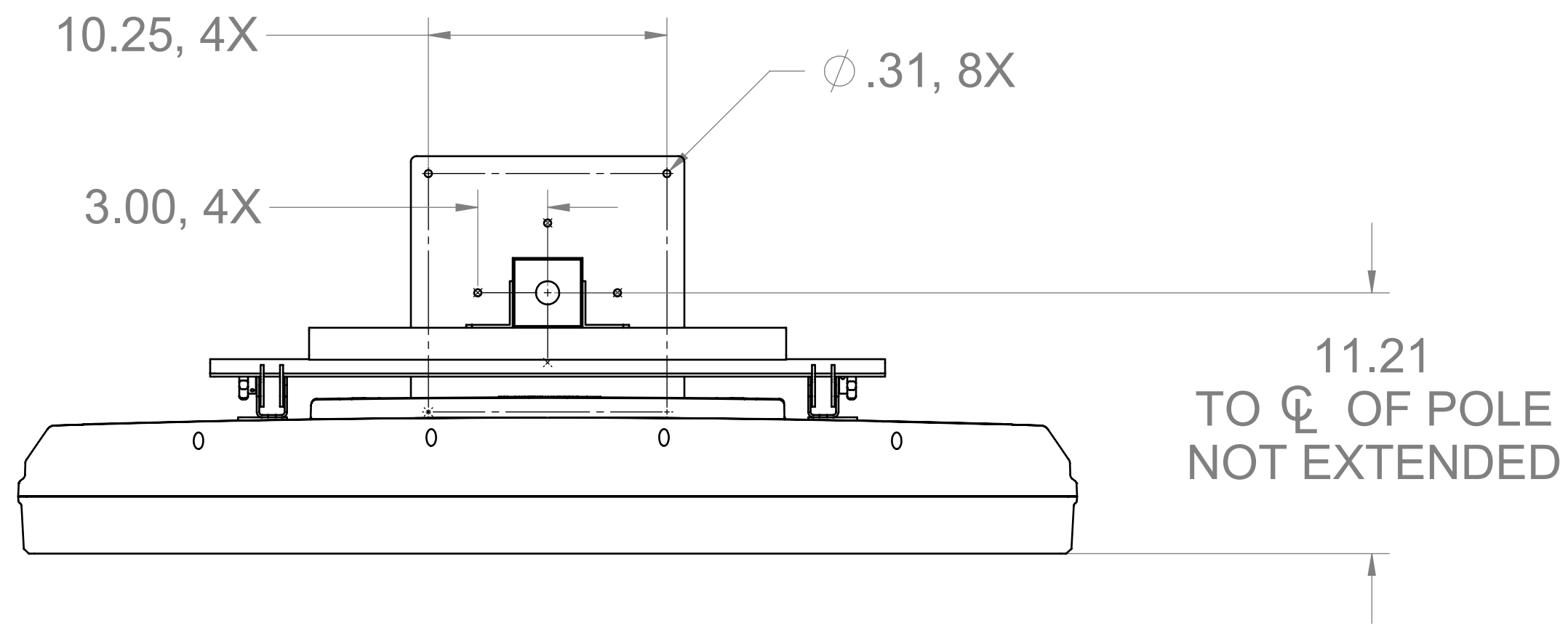

CHANGE BY DATE DESCRIPTION	TOLERANCES AND DIMENSIONING BEFORE PLATING UNLESS OTHERWISE SPECIFIED: DIMS INCHES mm X ±0.04 ±1 X.X ±0.03 ±0.5 X.XX ±0.015 ±0.1 X.XXX ±0.005 FRACTIONAL: ±0.03 ANGLE ±1/2° (BUT NOT OVER 0.03) HOLES ≤ φ .500 +0.003/-0.001 HOLES > φ .500 +0.005/-0.001 LOCATE φ TO ±0.015 (C) CONCENTRICITY 0.003 TIR REMOVE BURRS AND BREAK SHARP EDGES		FINISH: DRAWN TRW CHECKED TRW ENG APPR. TRW		PROPRIETARY AND CONFIDENTIAL THE INFORMATION CONTAINED IN THIS DRAWING IS THE SOLE PROPERTY OF SUNBRITEV LLC. ANY REPRODUCTION IN PART OR AS A WHOLE WITHOUT THE WRITTEN PERMISSION OF SUNBRITEV LLC IS PROHIBITED.	
	SCALE: 1:6		TITLE: 09112501_sb4630 tech drawings		DWG. NO.	
	DATE:		DO NOT SCALE DRAWING		SHEET 3 OF 7	
	REV		REV		REV	



09112501_sb4630 tech drawings

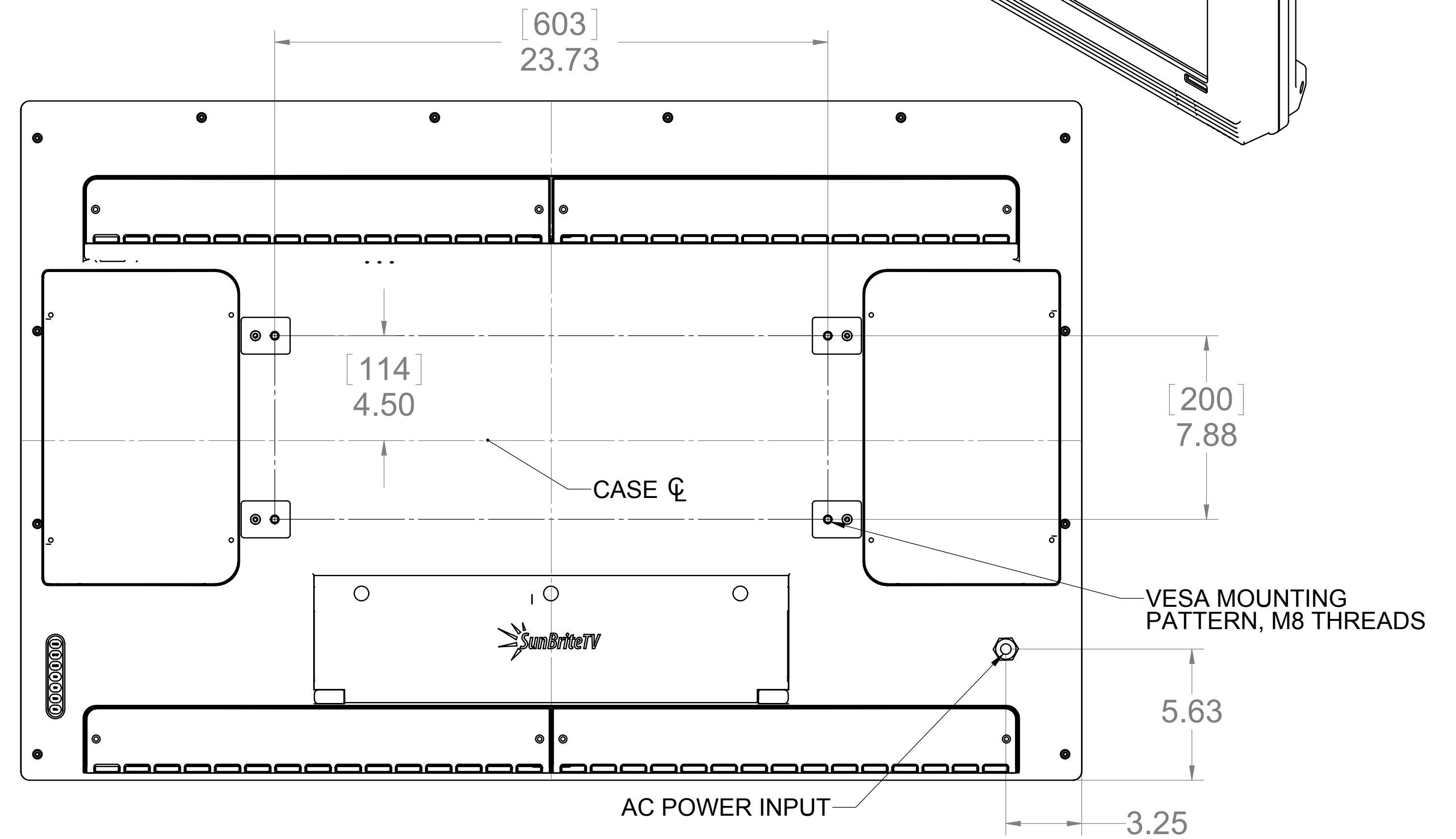
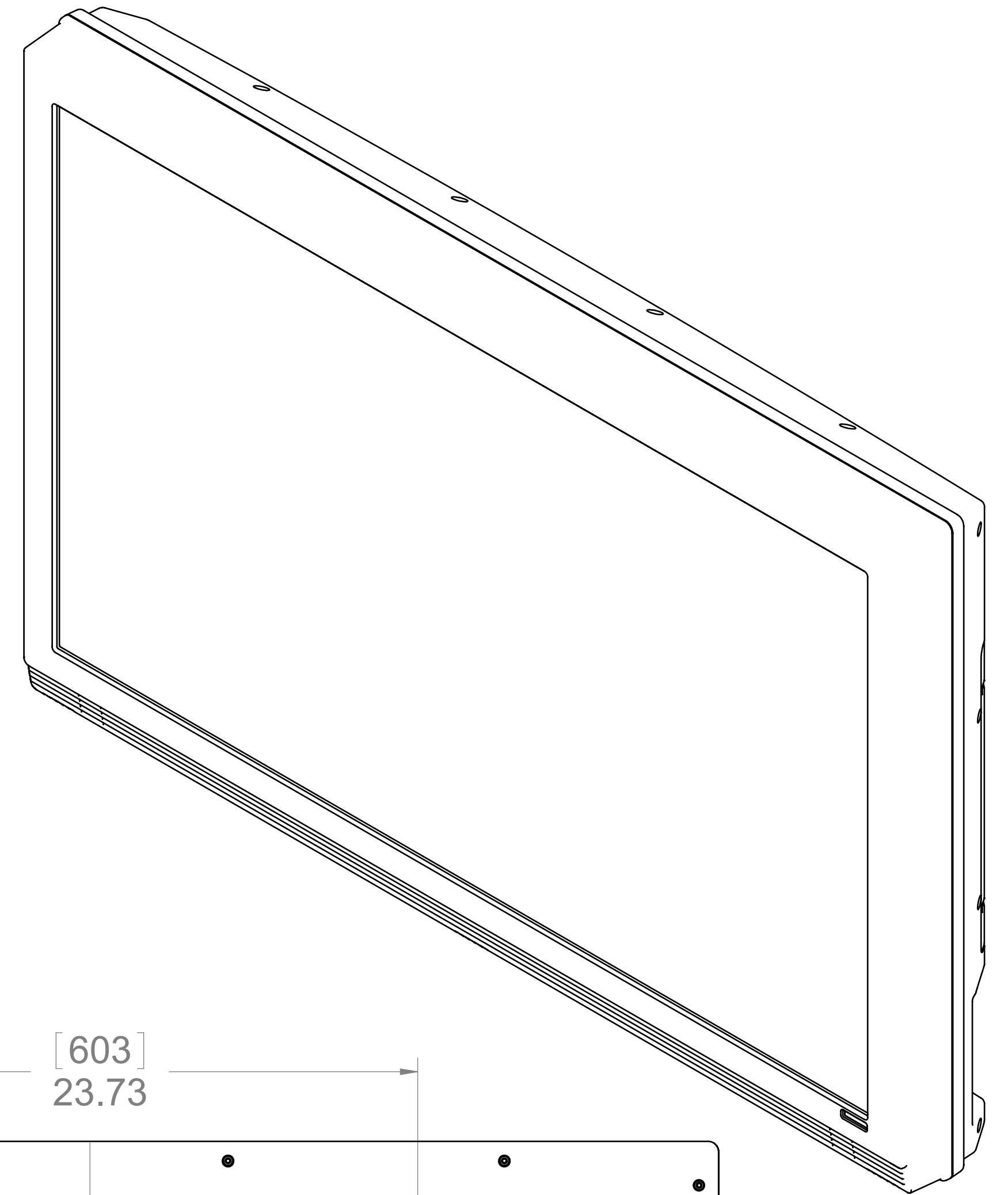
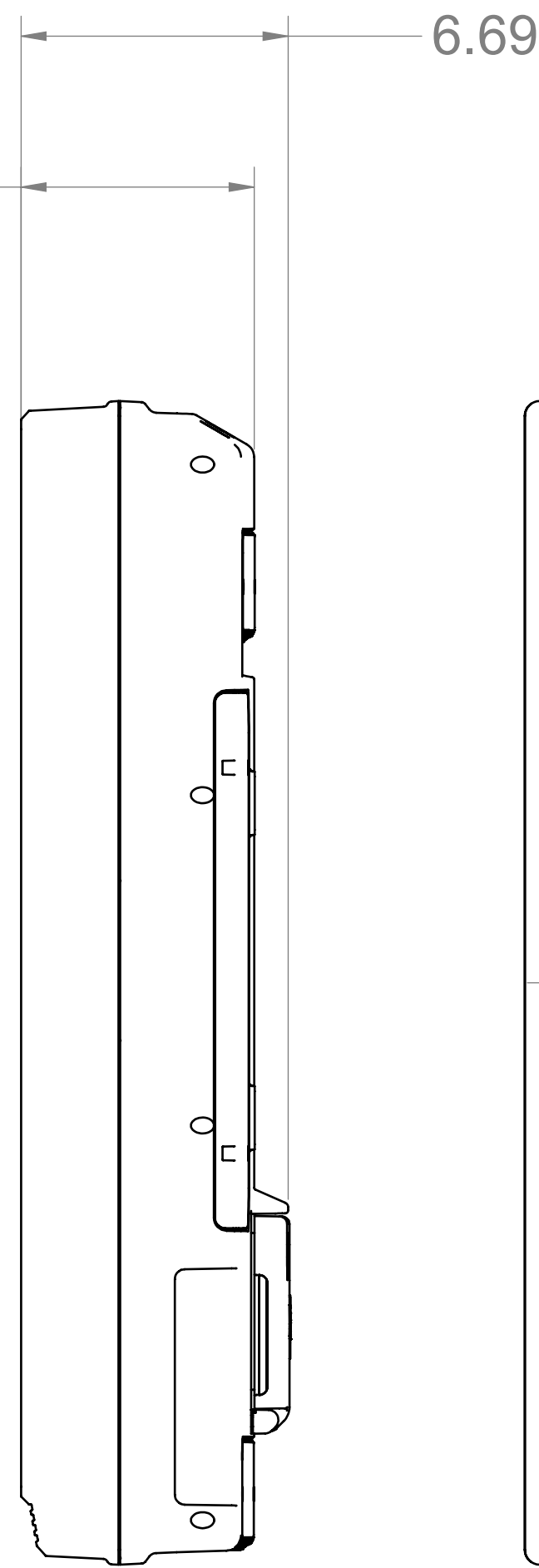
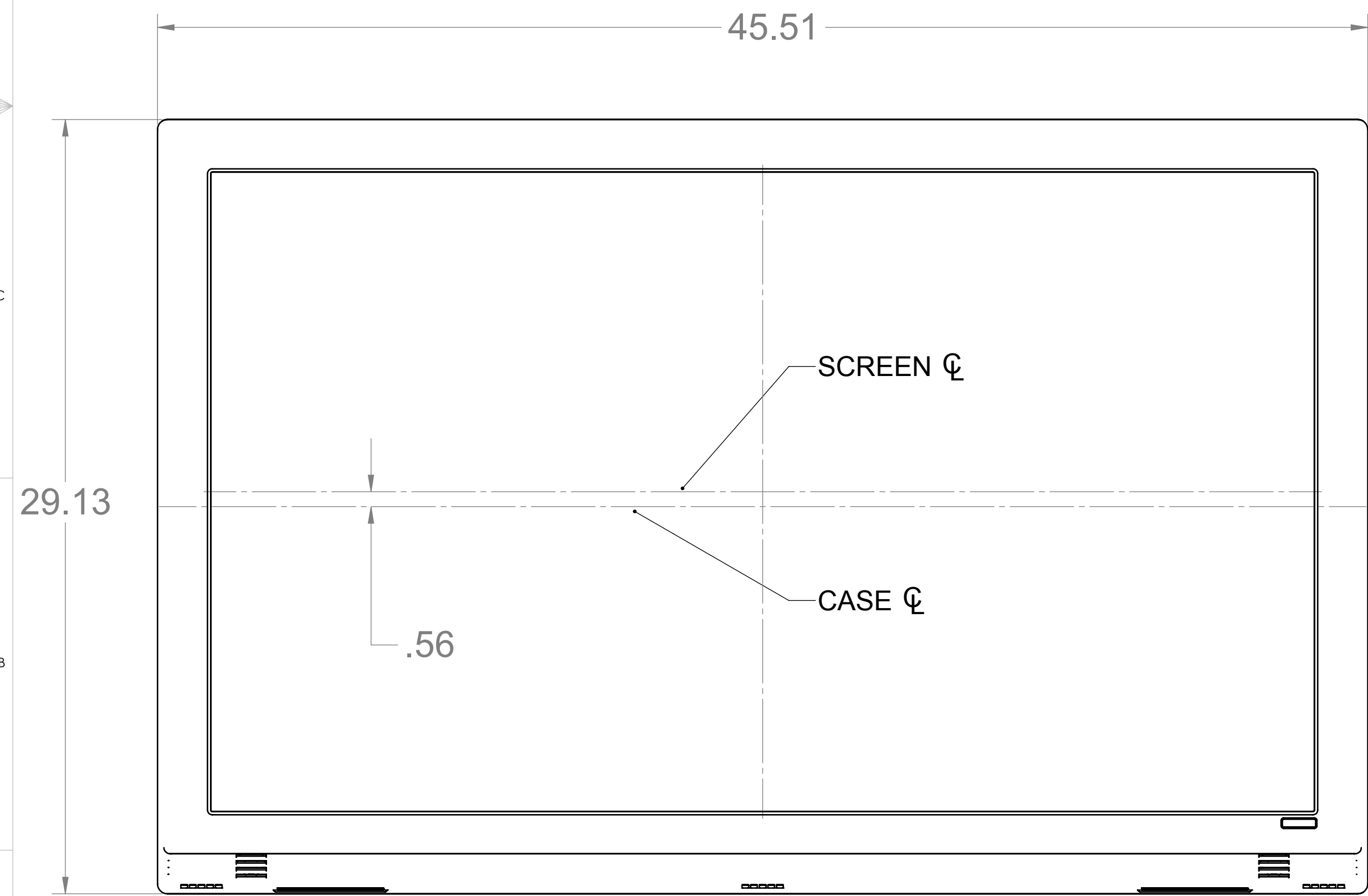
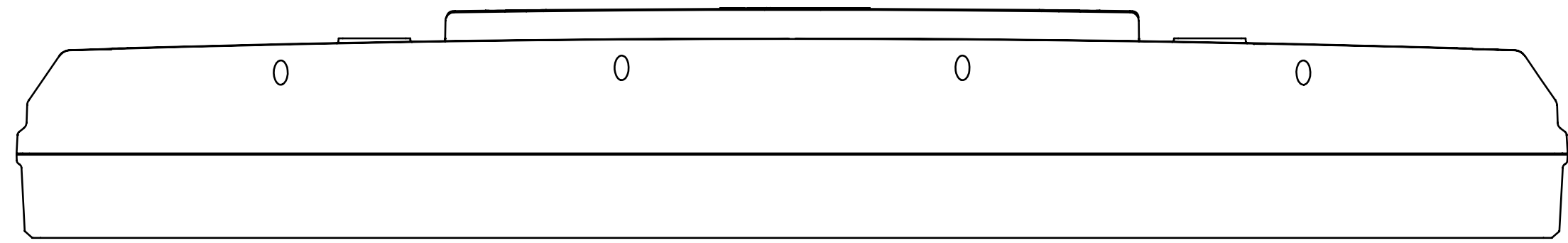

DIMS INCHES mm X.X ±0.04 ±1 X.XX ±0.03 ±0.5 X.XXX ±0.015 ±0.1 X.XXX ±0.005 FRACTIONAL: ±0.03 ANGLE ±1/2° (BUT NOT OVER 0.03) HOLES ≤ φ .500 +0.003/-0.001 HOLES > φ .500 +0.005/-0.001 LOCATE φ TO ±0.015 (C) CONCENTRICITY 0.003 TIR REMOVE BURRS AND BREAK SHARP EDGES	FINISH:	PROPRIETARY AND CONFIDENTIAL THE INFORMATION CONTAINED IN THIS DRAWING IS THE SOLE PROPERTY OF SUNBRITETV LLC. ANY REPRODUCTION IN PART OR AS A WHOLE WITHOUT THE WRITTEN PERMISSION OF SUNBRITETV LLC IS PROHIBITED.	SunBriteTV	
	DRAWN TRW CHECKED TRW ENG APPR. TRW			TITLE: 09112501_sb4630 tech drawings
	SCALE: 1:4 DATE:			DO NOT SCALE DRAWING DWG. NO. 1 SHEET 4 OF 7
	CHANGE RTR DATE DESCRIPTION			REV

09112501_sb4630 tech drawings

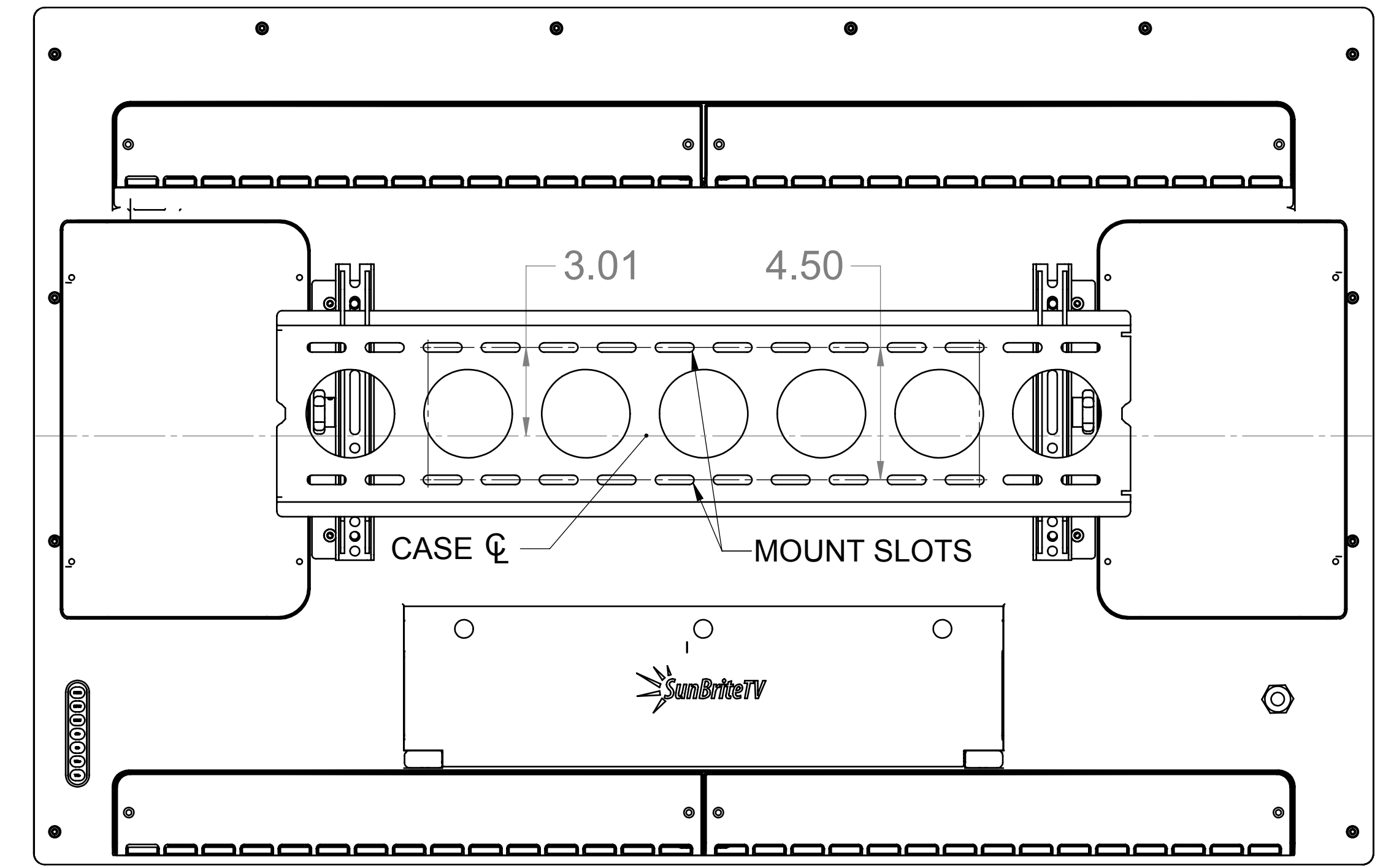
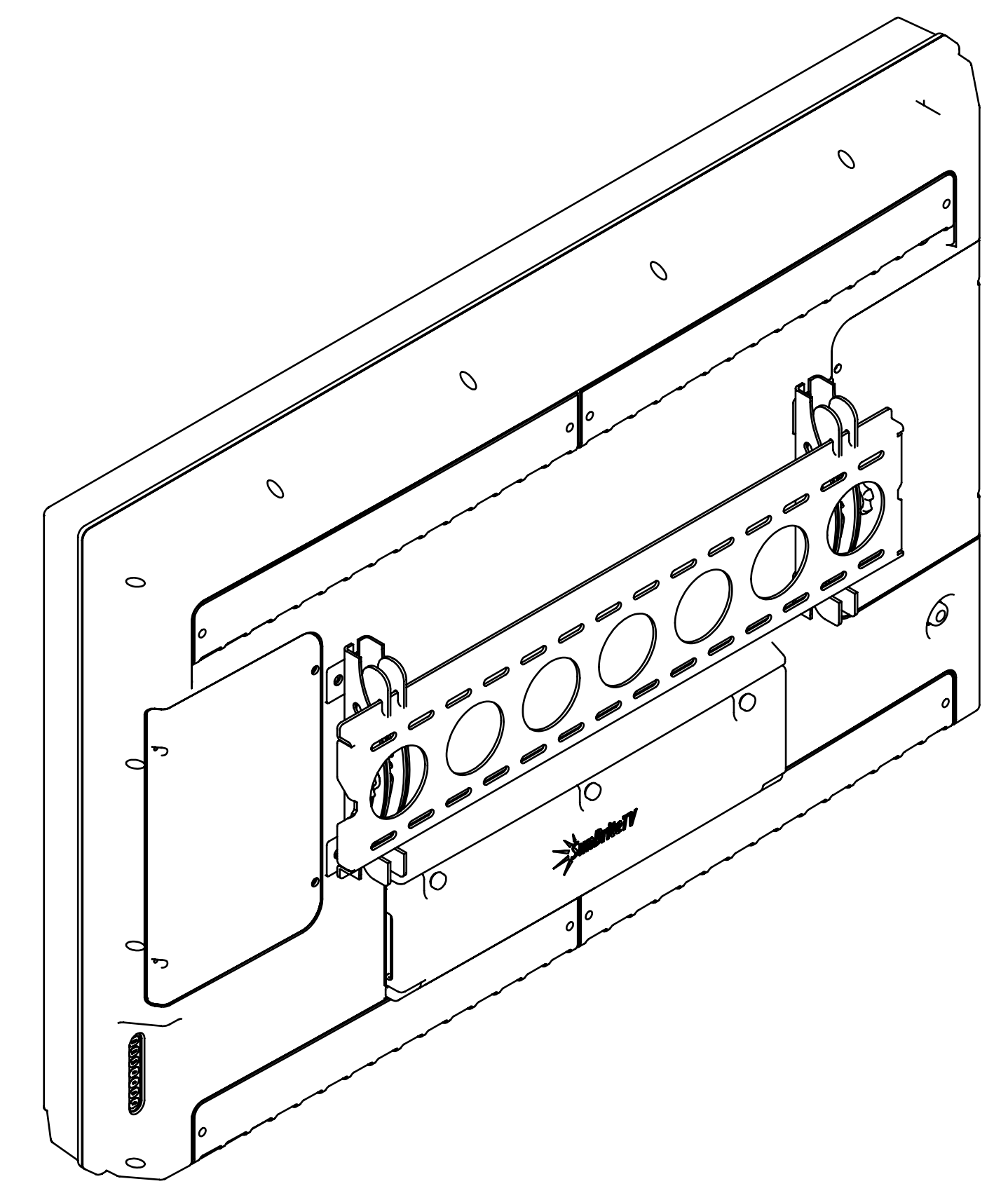
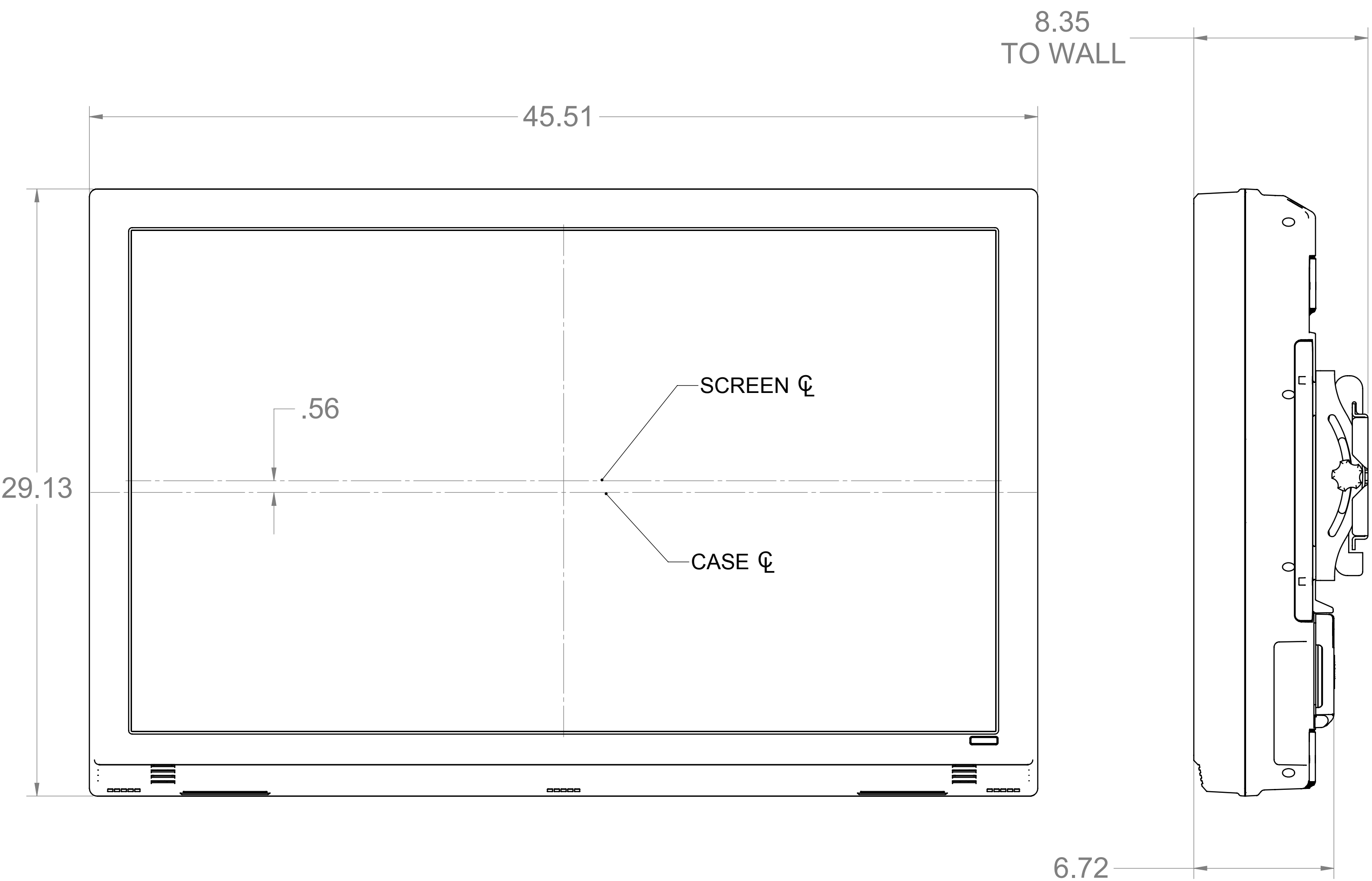
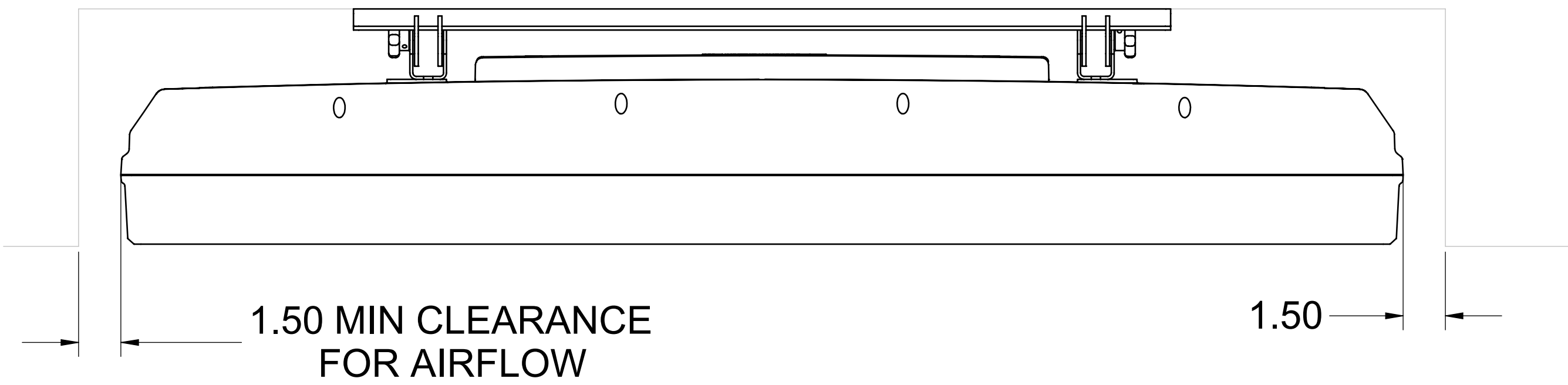

TOLERANCES AND DIMENSIONING BEFORE PLATING UNLESS OTHERWISE SPECIFIED: DIMS INCHES mm X.X ±0.04 ±1 X.XX ±0.03 ±0.5 X.XXX ±0.015 ±0.1 X.XXX ±0.005 FRACTIONAL: ±0.03 ANGLE ±1/2° (BUT NOT OVER 0.03) HOLES ≤ φ .500 +0.003/-0.001 HOLES > φ .500 +0.005/-0.001 LOCATE φ TO ±0.015 (C) CONCENTRICITY 0.003 TIR REMOVE BURRS AND BREAK SHARP EDGES	FINISH:	PROPRIETARY AND CONFIDENTIAL THE INFORMATION CONTAINED IN THIS DRAWING IS THE SOLE PROPERTY OF SUNBRITETV LLC. ANY REPRODUCTION IN PART OR AS A WHOLE WITHOUT THE WRITTEN PERMISSION OF SUNBRITETV LLC IS PROHIBITED.		
	DRAWN TRW CHECKED TRW ENG APPR. TRW	TITLE: 09112501_sb4630 tech drawings		
	SCALE: 1:4 DATE:	DO NOT SCALE DRAWING SHEET 5 OF 7	DWG. NO. 1	REV
	CHANGE BY DATE DESCRIPTION			

09112501_sb4630 tech drawings



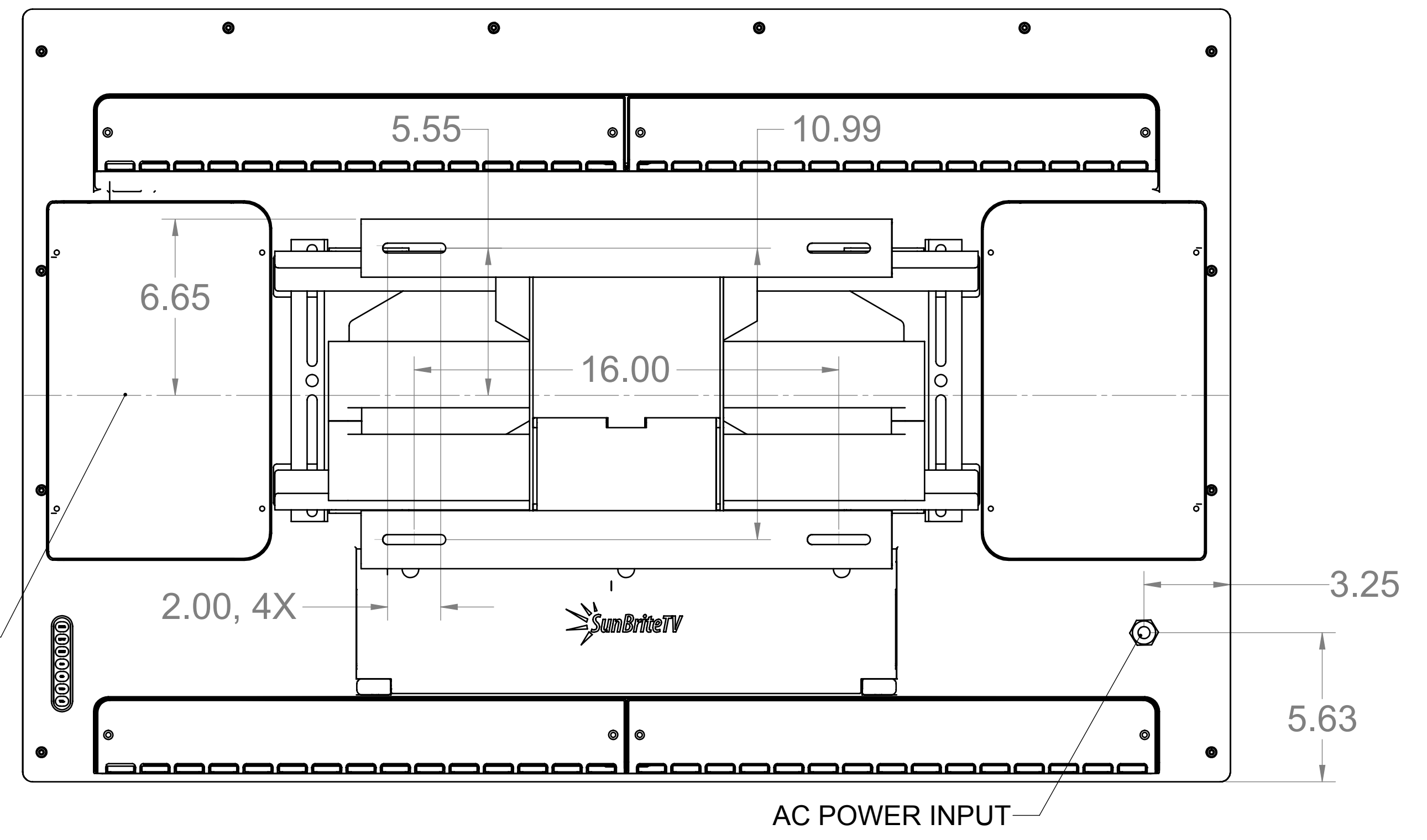
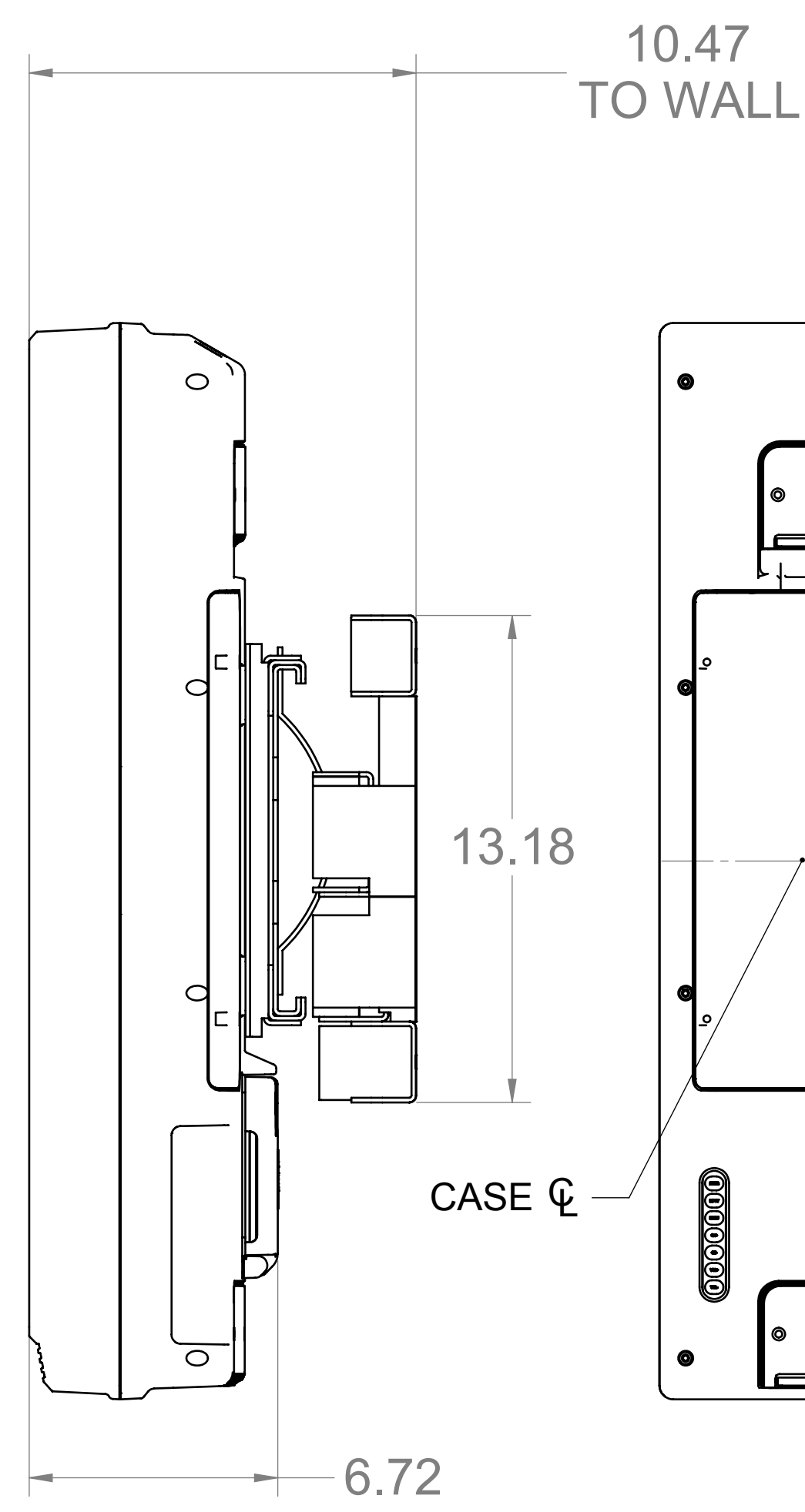
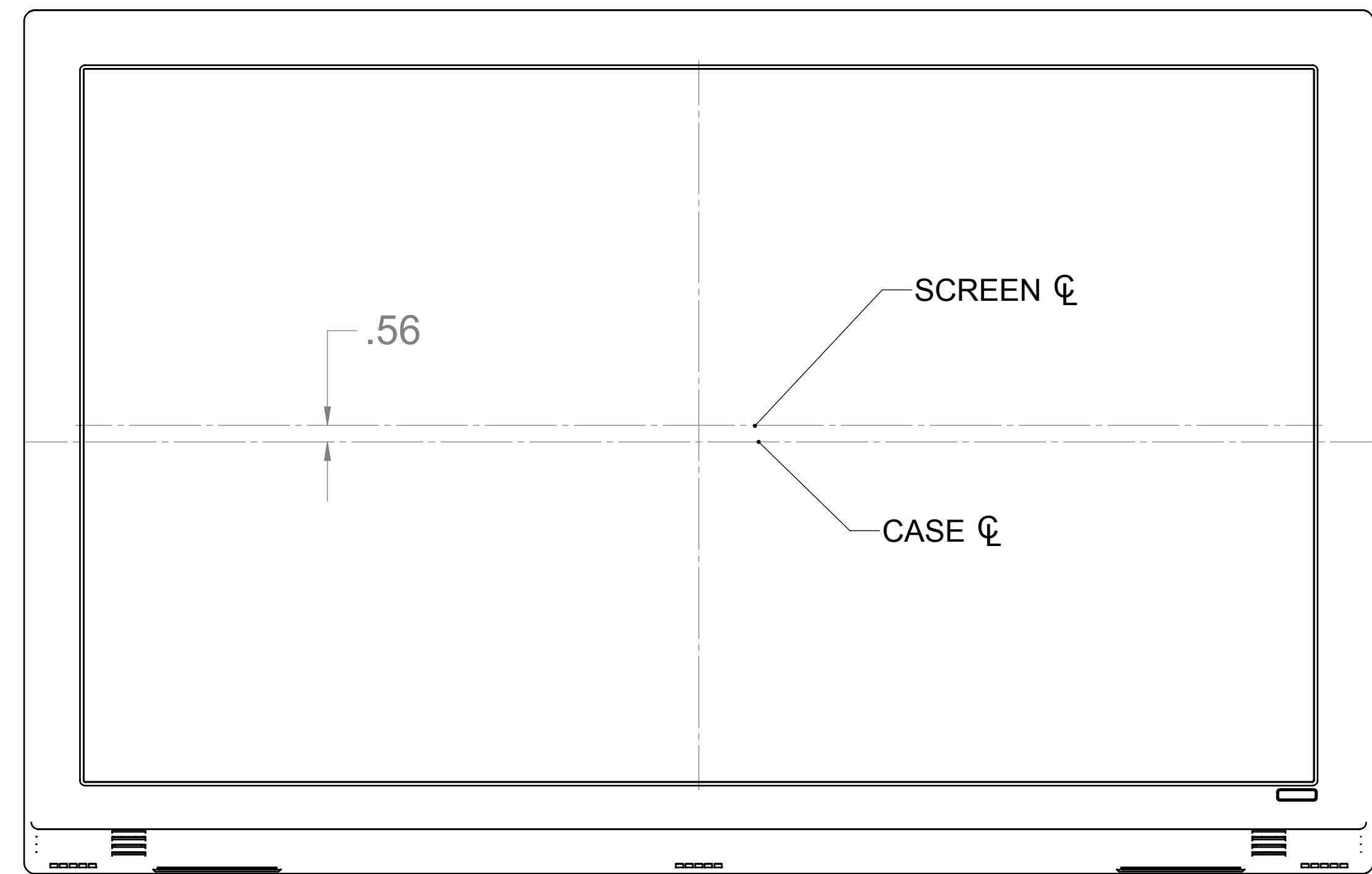
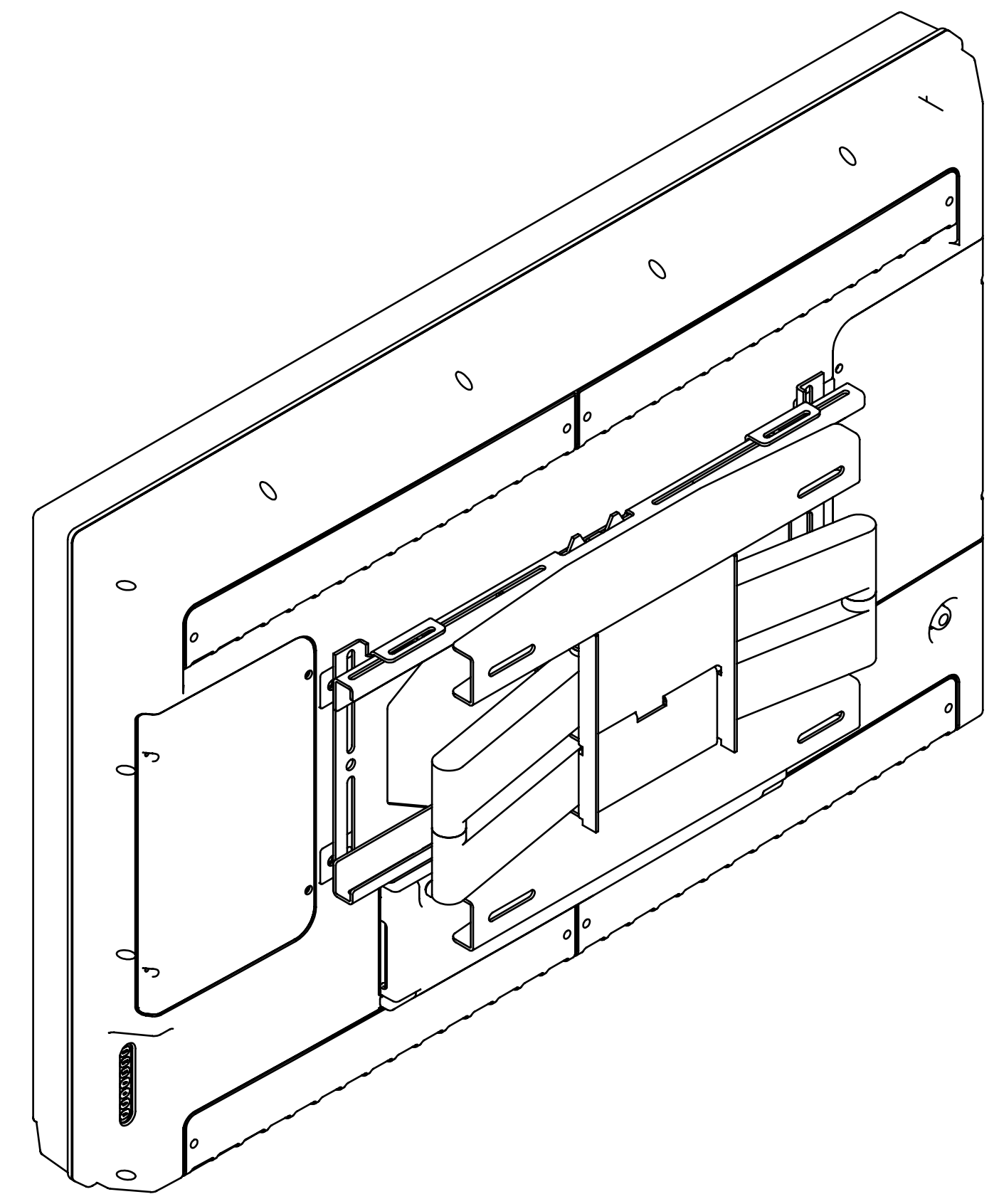
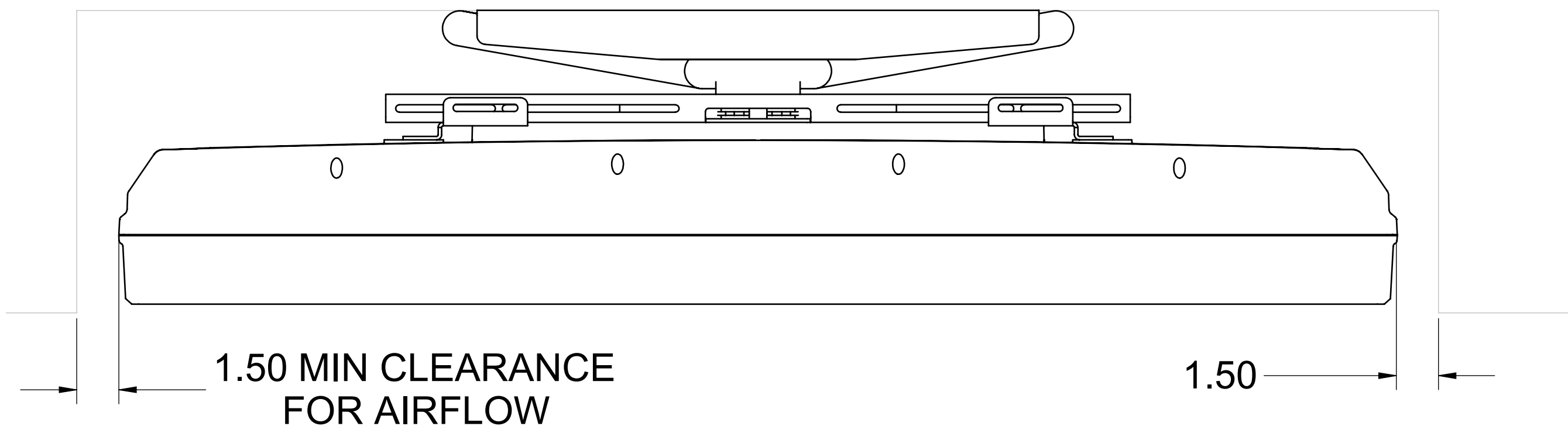

TOLERANCES AND DIMENSIONING BEFORE PLATING UNLESS OTHERWISE SPECIFIED: DIMS INCHES mm X.X ±0.04 ±1.5 X.XX ±0.03 ±0.5 X.XXX ±0.015 ±0.1 X.XXX ±0.005 FRACTIONAL: ±0.03 ANGLE ±1/2° (BUT NOT OVER 0.03) HOLES ≤ φ .500 +0.003/-0.001 HOLES > φ .500 +0.005/-0.001 LOCATE φ TO ±0.015 (C) CONCENTRICITY 0.003 TIR REMOVE BURRS AND BREAK SHARP EDGES	FINISH:	PROPRIETARY AND CONFIDENTIAL THE INFORMATION CONTAINED IN THIS DRAWING IS THE SOLE PROPERTY OF SUNBRITETV LLC. ANY REPRODUCTION IN PART OR AS A WHOLE WITHOUT THE WRITTEN PERMISSION OF SUNBRITETV LLC IS PROHIBITED.		
	DRAWN TRW CHECKED TRW ENG APPR. TRW			TITLE: 09112501_sb4630 tech drawings
	SCALE: 1:4 DATE:			DO NOT SCALE DRAWING DWG. NO. REV
	SHEET 6 OF 7			SHEET 6 OF 7

09112501_sb4630 tech drawings

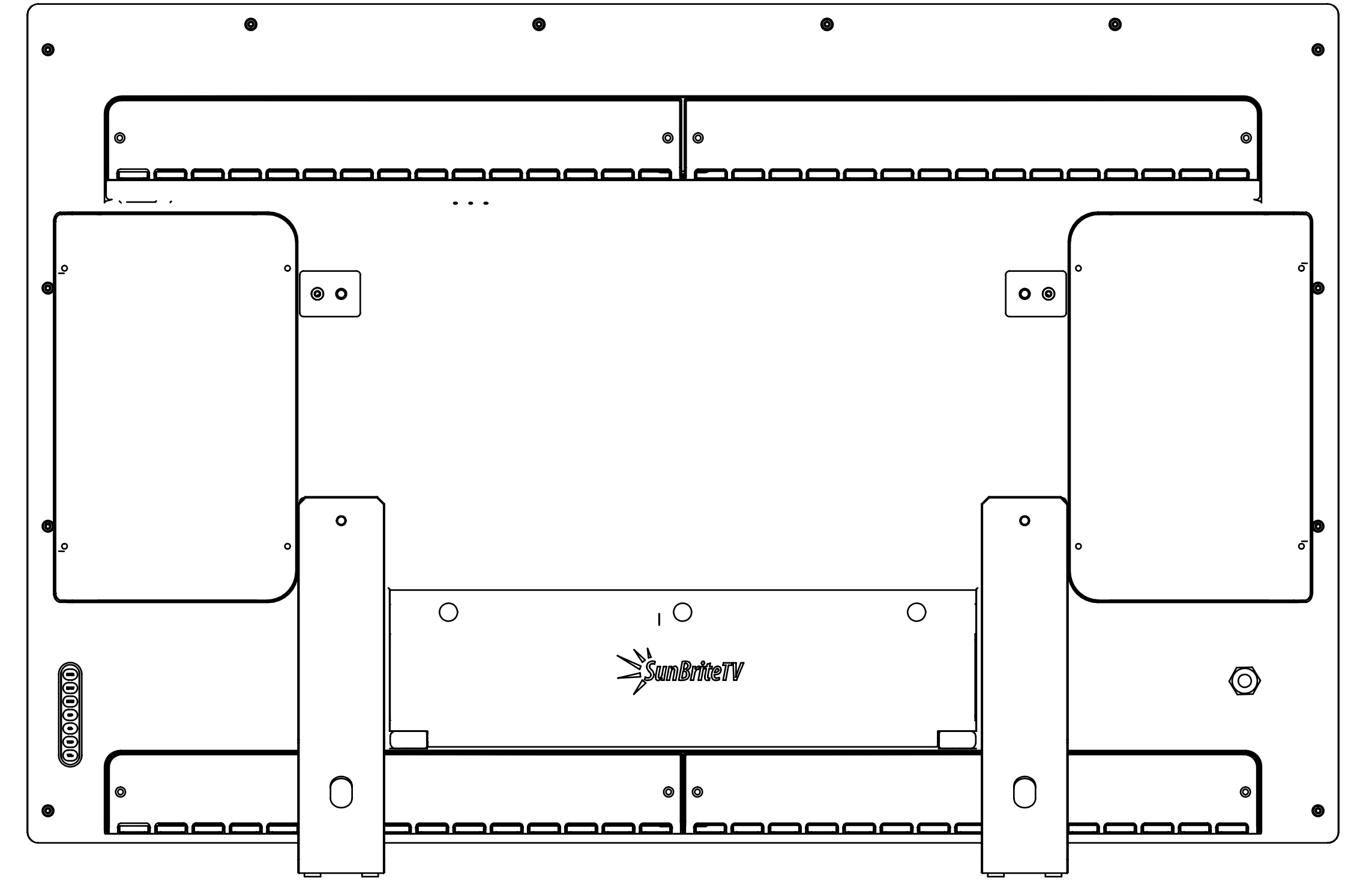
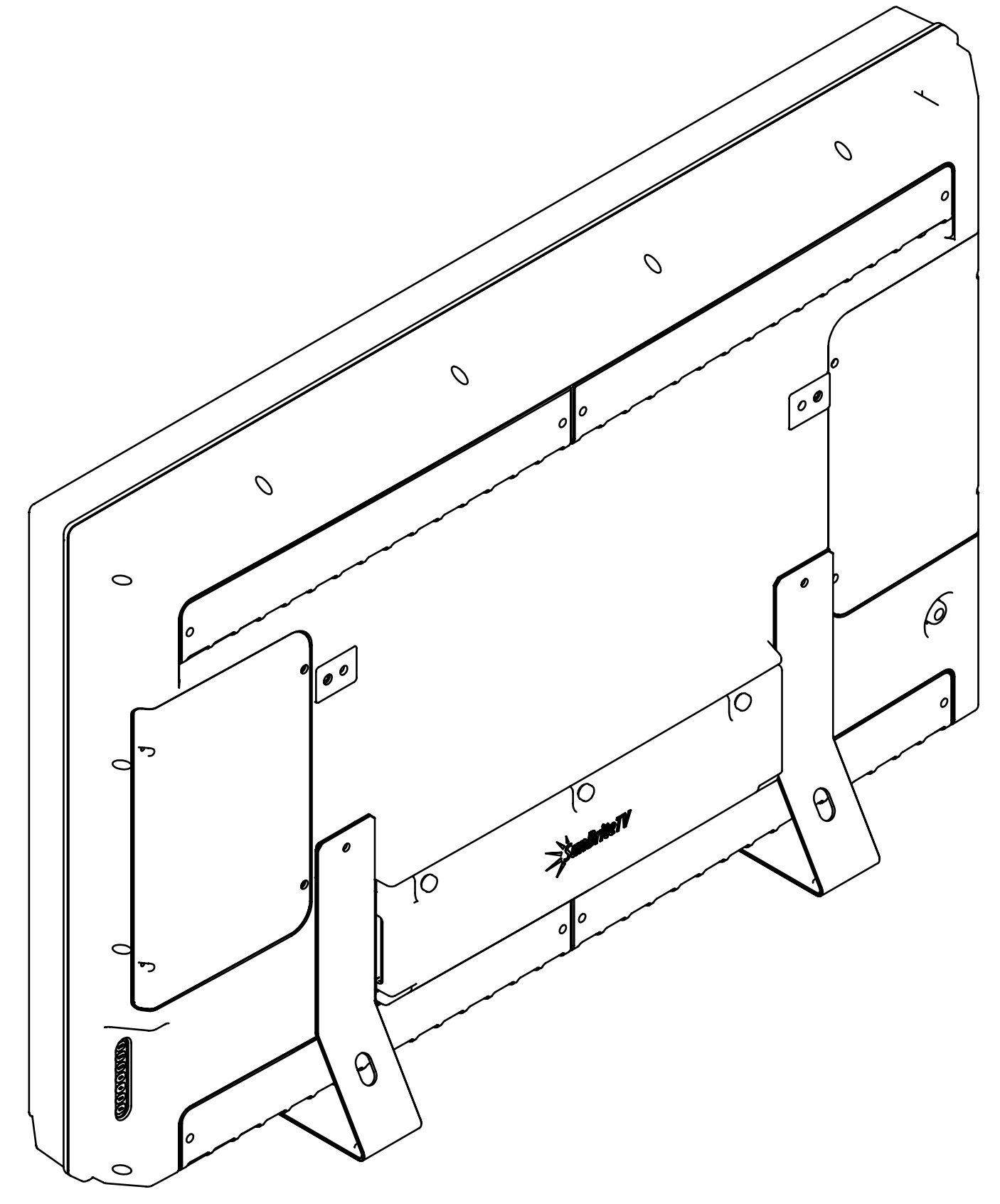
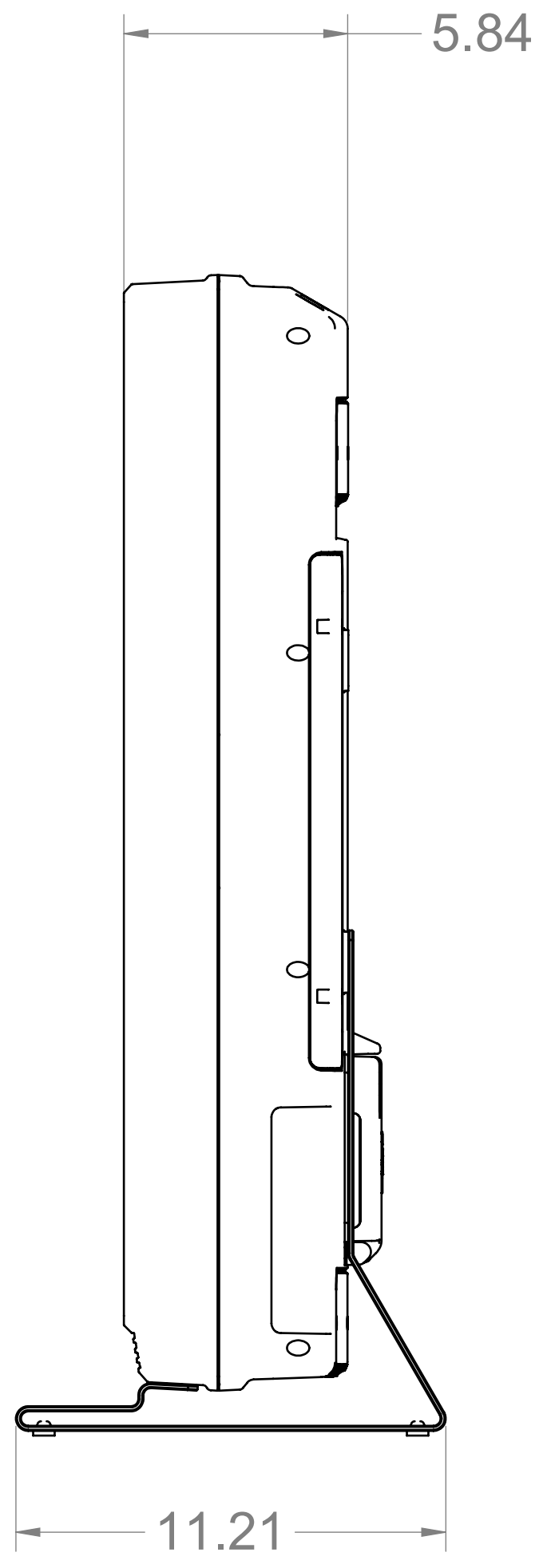
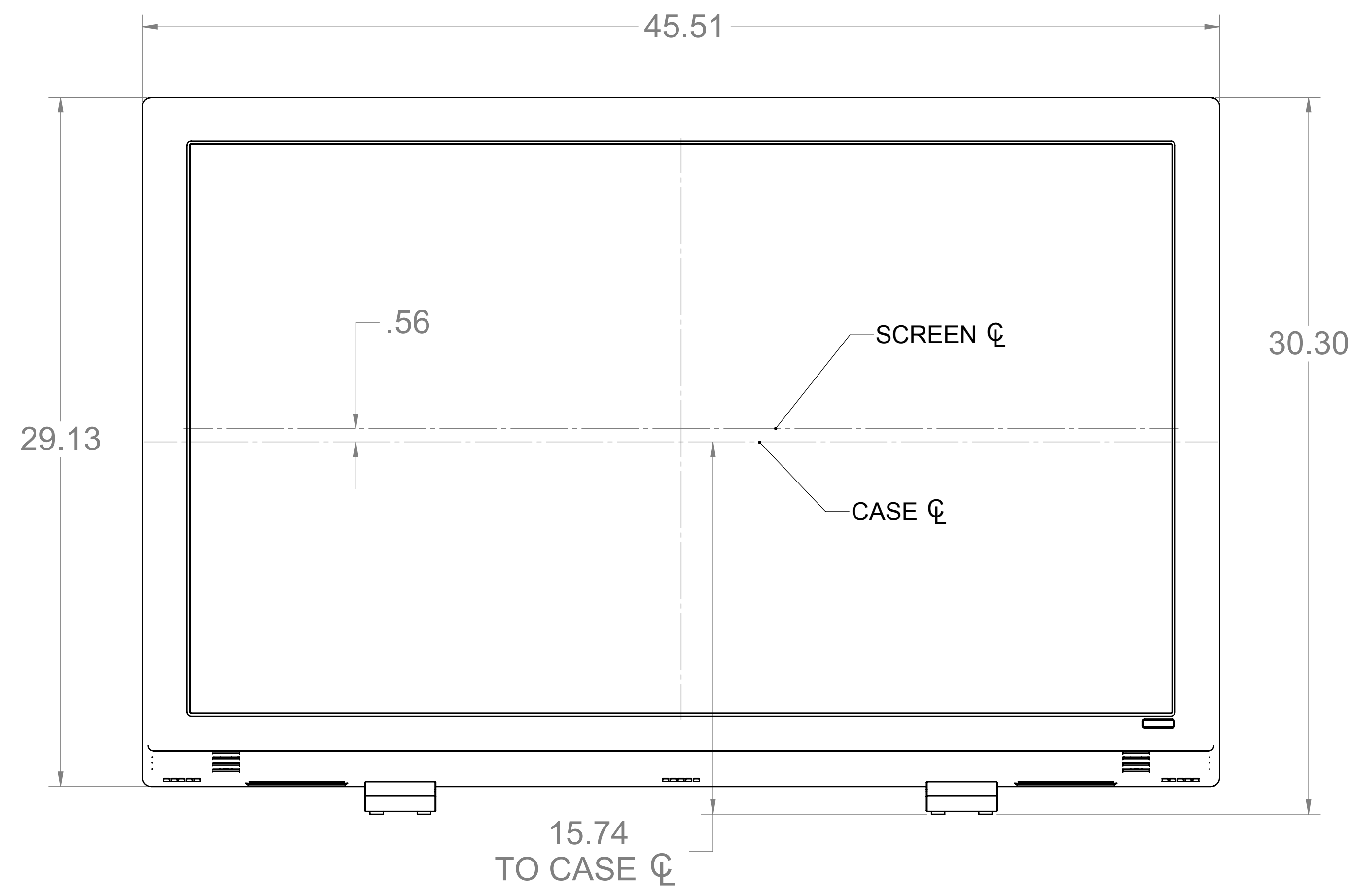
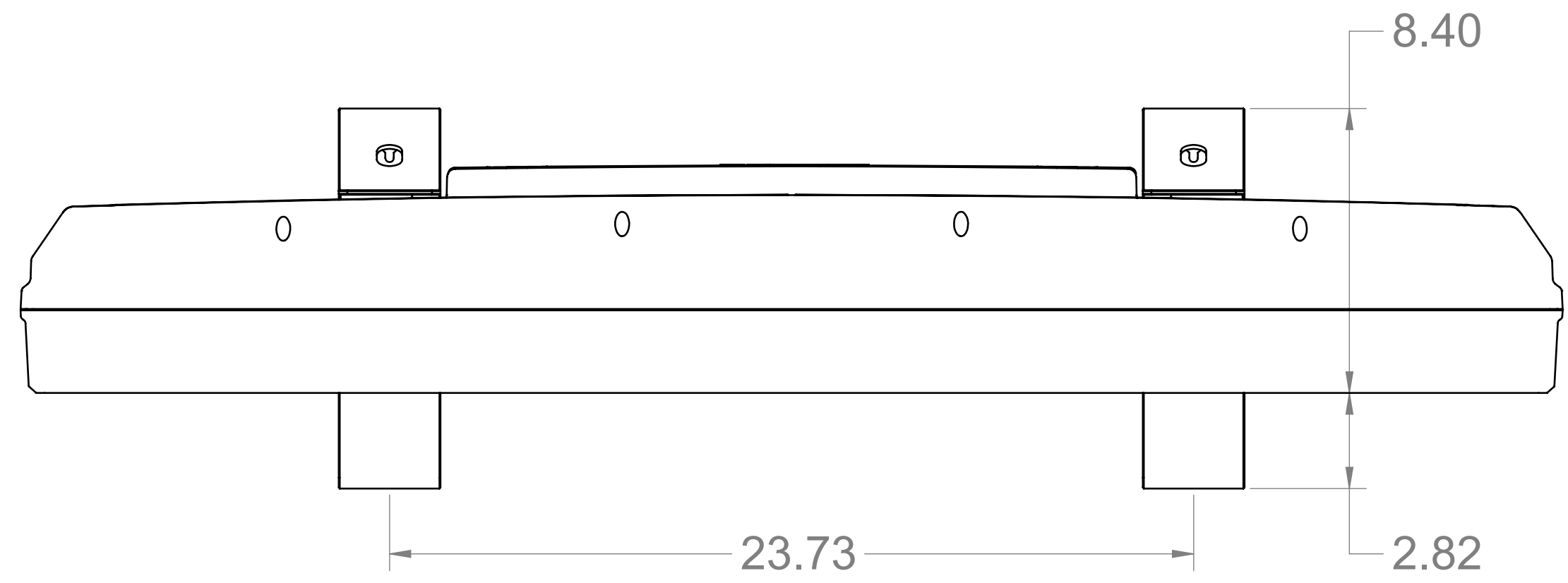

CHANGES BY DATE DESCRIPTION	TOLERANCES AND DIMENSIONING BEFORE PLATING UNLESS OTHERWISE SPECIFIED:		FINISH:		PROPRIETARY AND CONFIDENTIAL THE INFORMATION CONTAINED IN THIS DRAWING IS THE SOLE PROPERTY OF SUNBRITETV LLC. ANY REPRODUCTION IN PART OR AS A WHOLE WITHOUT THE WRITTEN PERMISSION OF SUNBRITETV LLC IS PROHIBITED.	
	DIMS	INCHES	mm			
	X.X	+0.04	±1			
	X.XX	+0.03	±0.5			
X.XXX	+0.015	±0.1				
X.XXX	+0.005					
FRACTIONAL: ±0.03		ANGLE ±1/2° (BUT NOT OVER 0.03)		TITLE:		
HOLES ≤ φ .500 +0.003/-0.001		HOLES > φ .500 +0.005/-0.001		09112501_sb4630 tech drawings		
LOCATE φ TO ±0.015		LOCATE φ TO ±0.015		DO NOT SCALE DRAWING DWG. NO.		
(C) CONCENTRICITY 0.003 TIR		REMOVE BURRS AND BREAK SHARP EDGES		SCALE: 1:4		
				DATE:		
				SHEET 7 OF 7		
				REV		

09112501_sb4630 tech drawings