

## FFAR21L

19.0" x 18.63" x 17.25" (H x W x D)

Compact 1.8 cu.ft. all-refrigerator with automatic defrost and front lock

### Highlights:

- Perfectly sized compact to fit tight spaces
- Automatic defrost saves you time and maintenance
- Factory-installed lock provides security you can depend on
- Cold wall interior for easier cleanup



|                            |  |
|----------------------------|--|
| Front-mounted lock         | Keyed lock for a secure interior                                 |
| Automatic defrost          | Reduced maintenance with auto defrost system                     |
| Door storage               | Store items right on the door for easy access                    |
| Reversible door            | User reversible door swing                                       |
| Adjustable thermostat      | Manage the temperature with ease and accuracy                    |
| Matching freezer available | Matches SUMMIT FS21L all-freezer                                 |
| Cold wall design           | No exposed evaporator  |
| 100% CFC                   | Environmentally friendly design without ozone-damaging chemicals |

## Specifications:

|                            |                |
|----------------------------|----------------|
| Height                     | 19.0"          |
| Width                      | 18.63"         |
| Depth                      | 17.25"         |
| Capacity                   | 1.77 cu.ft.    |
| Interior Height 1          | 15.5"          |
| Interior Width 1           | 16.0"          |
| Interior Depth 1           | 14.0"          |
| Comp Step Height           | 8.0"           |
| Comp Step Width            | 16.0"          |
| Comp Step Depth            | 5.5"           |
| Shipping Weight            | 55.0 lbs.      |
| Weight                     | 38.0 lbs.      |
| Energy Usage/Year          | 248.2 kWh/year |
| Canadian Electrical Safety | ULC            |
| Amps                       | 1.2            |
| US Electrical Safety       | UL             |
| Voltage/Frequency          | 115 V AC/60 Hz |
| Reversible                 | Yes            |
| Door Swing                 | RHD            |
| Shelf Quantity             | 1              |
| Shelf Type                 | Wire           |
| Full Door Shelf Quantity   | 1              |
| Half Door Shelf Quantity   | 1              |
| Defrost Type               | Automatic      |
| Height to Hinge Cap        | 19.38"         |
| Depth with door at 90°     | 34.38"         |
| Thermostat Type            | Dial           |
| Condensor Location         | Side of Unit   |
| Level Legs Quantity        | 2              |
| Compressor Warranty        | 5 Years        |
| Parts/Labor Warranty       | 1 Year         |

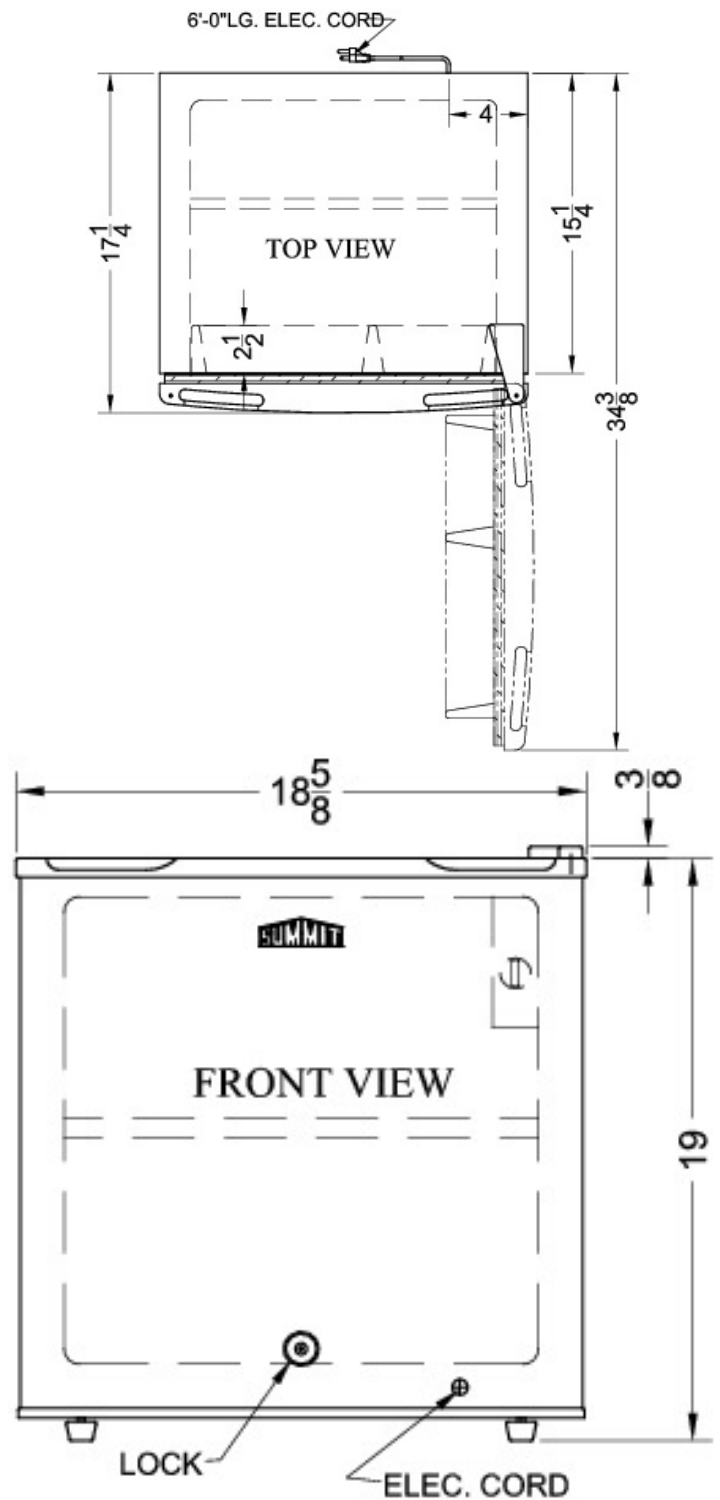

Summit Appliance Division, Felix Storch, Inc.  
 770 Garrison Ave • Bronx, NY 10474  
 Phone: 718-893-3900 • Fax: 718-842-3093  
 Email: info@summitappliance.com