CATALOGO DE REFACCIONES

Refrigerador 2 puertas deshielo automático

Summit

Modelos:

FF1320W

FF1325SS

(115 - 127, 60Hz)

PARTES PARA PUERTA

FF1320W
FF1325SS

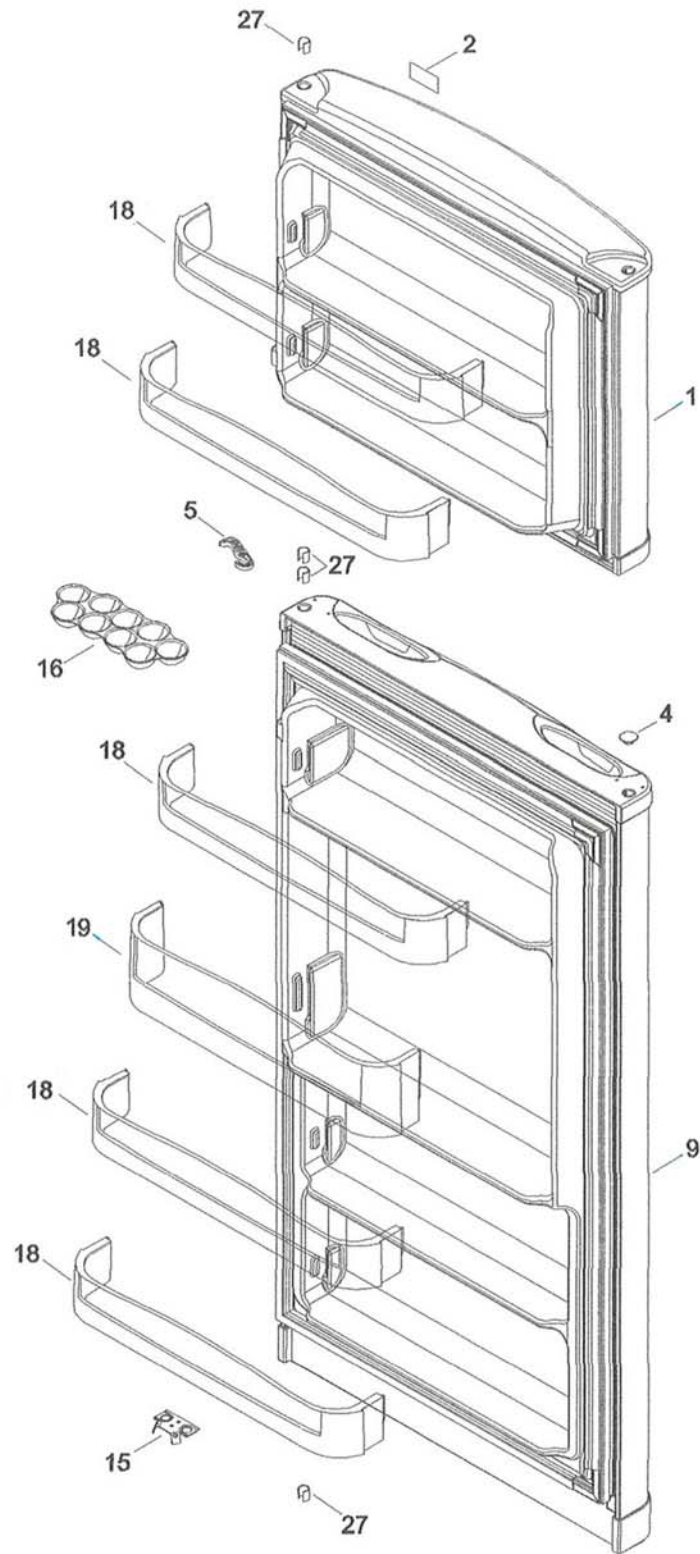

PARTES PARA GABINETE

FF1320W
FF1325SS

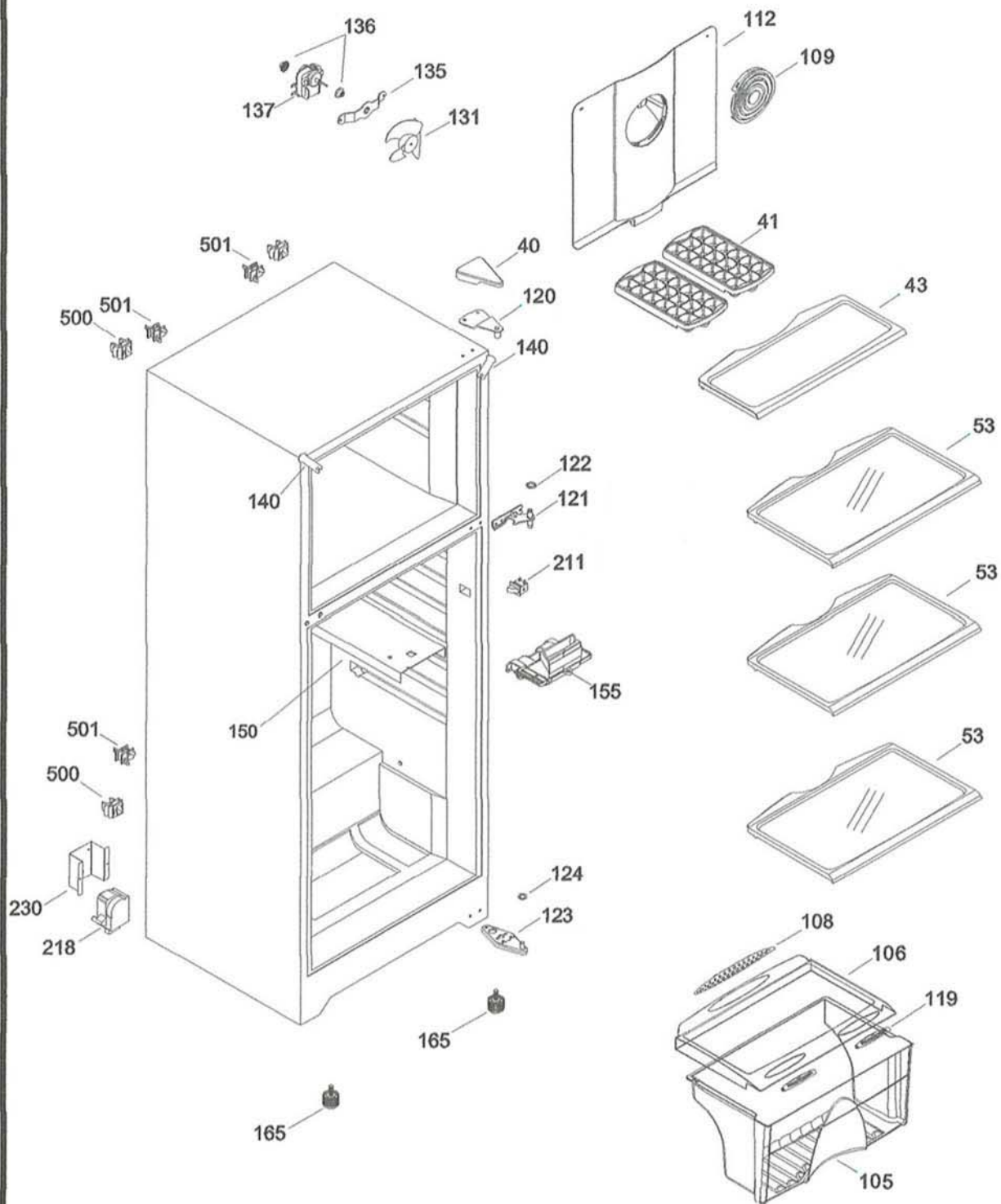

106 TAPA CAJON LEGUMBRES ENS.

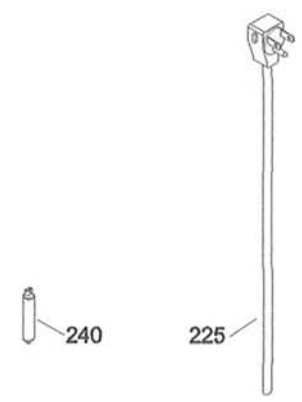
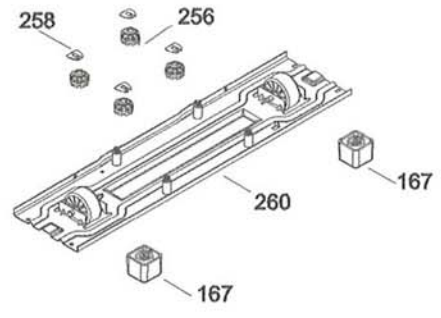
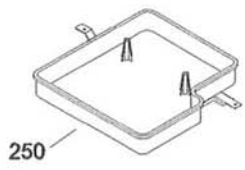
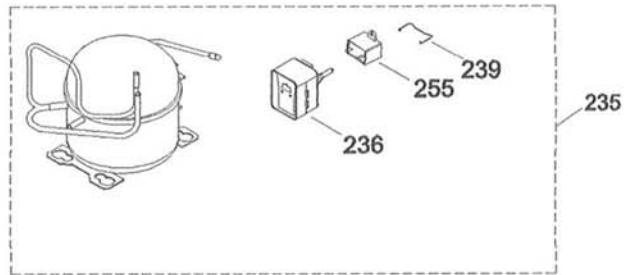
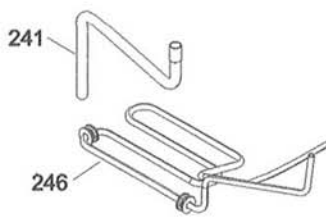
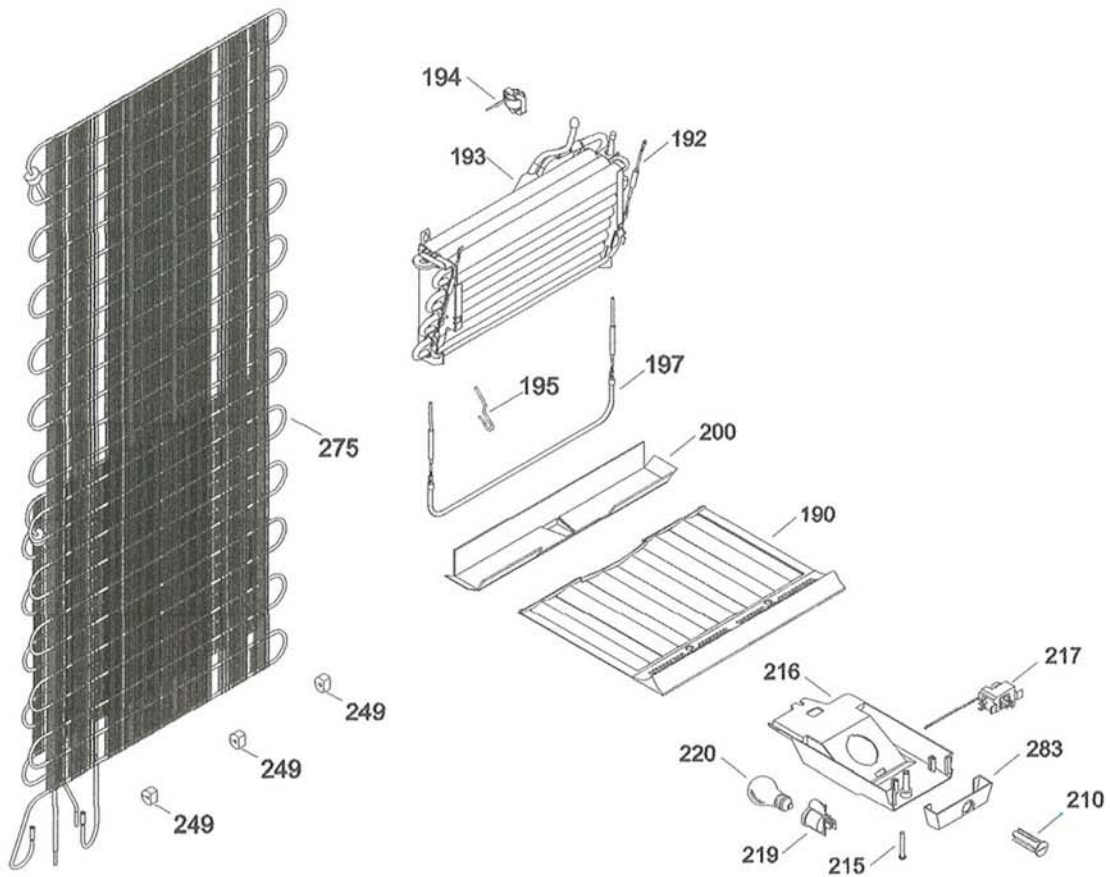

SUMMIT

FF1320W
FF1325S

Guide	Part Number	Description		
1	200D2728G067	CURVE FZ DOOR ASM (WH)	1	
1	200D2728G073	FZ FOAM DOOR ASM		1
2	355B2132P001	NAMEPLATE SUMMIT	1	1
4	238C1221P001	PLUG BUTTON THIMBLE (WH)	1	
4	238C1221P005	PLUG BUTTON THIMBLE (GRAY)		1
5	200D3835P002	STOP FZ DOOR FORCED CLOSIN	1	1
9	200D2755G052	FF FOAM DOOR ASM		1
9	8014140	CURVE FF DOOR ASM (WH)	1	
15	238C2045P001	STOP DOOR FF	1	1
16	238C1489P003	RACK EGGS		1
16	238C1489P006	RACK EGGS	1	
18	200D2698P001	SHELF FRONT DOOR FZ/FF	5	5
19	200D2699P001	SHELF FRONT DOOR FF	1	1
27	238C2207P001	DOOR BUSHING	4	4
40	186D1080P001	COVER HINGE (WH)	1	
40	186D1080P005	COVER HINGE (GRAY)		1
41	200D2953P003	ICE TRAY	2	2
43	200D3656G002	CRISTAL SHELF FZ ASM.	1	1
53	200D3657G002	CRISTAL SHELF FF ASM.	3	3
105	200D2717P001	VEG PAN	1	1
106	200D3921G013	GLASS PAN COVER ASM		1
106	200D3921G014	GLASS PAN COVER ASM	1	
108	200D2796P004	INSERT VEG PAN COVER		1
108	200D2796P007	INSERT VEG PAN COVER	1	
109	200D2778P013	FZ AIR DIFFUSER	1	
109	200D2778P014	FZ AIR DIFUSER		1
112	200D3202G036	COVER EVAP ASM	1	
112	200D3202G037	COVER EVAP ASM		1
119	200D2681P001	HUMIDITY CONTROL	2	2
120	355B1769G002	HINGE TOP & SHIM ASM	1	1
121	355B1718G009	HINGE CTR ASM	1	1
122	238C1981P001	SPACER HINGE	1	1
123	355B1530G001	HINGE BTM ASM	1	1
124	203C2032P010	WHASER BTM HINGE	2	2
131	197D3131G006	BLADE EVAP FAN & RING ASM	1	1

PARTES DE RAPIDO MOVIMIENTO/FAST MOVING PARTS

SUMMIT

F F
F F
1 1
3 3
2 2
0 5
W S
S

Guide	Part Number	Description		
	238C1189P001	BRACKET MOTOR FAN	1	1
	221C5143P001	GROMMET FAN	2	2
	200D2940P002	MOTOR EVAP FAN	1	1
	355B2047P001	CAB CORNER (WH)	2	
	355B2047P004	CAB CORNER		2
	221C7102P001	INSUL ELECT	1	1
	221C7094G001	DUCT FOAM & COVER FF ASM	1	1
	314B8640P009	GLIDER SCREW	2	2
	238C2459P001	SUPPORT COMPRESSOR PLATE	2	1
	186D2805P001	FLOOR FZ	1	1
	200D6739G001	EVAPORATOR ASM	1	1
	221C8290P002	ACCUMULATOR	1	1
	238C1015P008	DEF THERMOSTAT	1	1
	238C2646P001	HEATER CONDUCTION	1	1
	238C2216G007	HEATER & FUSE ASM 180W/120V BK	1	1
	186D2836P001	TROUGH DRAIN	1	1
	186D1664P018	KNOB CONTROL (WH)	1	1
	314B8274P001	SWITCH LIGHT	1	1
	314B8355P001	SCREW 8-19 HI/LO	1	1
	186D2923P002	HOUSING CONTROL	1	1
	200D5822P001	CONTROL TEMP	1	1
	162D6022P006	CONTROL DEFROST (115-127V)	1	1
	186D1259G001	SOCKET & TERMINAL ASM	1	1
	314B9124P001	LAMP (25 W)	1	1
	186D2830G008	HARNESS POWER	1	1
	314B8630P001	SUPPORT CONTROL DEFROST	1	1
	20505212499	COMPRESSOR CBE121L2G ASM	1	1
	200D5578P008	ACC.ELEC. 5SP16B317RH 10025	1	1
	355B2089P004	5SP CLIP RETAINER	1	1
	221C5100P002	DRYER	1	1
	314B8606P001	DRAIN TUBE	1	1
	221C8378G004	AUXILIAR TUBE ASM	1	1
	314B9163P003	GROMMET, CONDENSER	3	3
	238C2234G001	EVAPORATOR PAN ASM	1	1
	203C2799P004	CAPACITOR	1	1

PARTES DE RAPIDO MOVIMIENTO/FAST MOVING PARTS

SUMMIT

F F
 1 1
 3 3
 2 2
 0 5
 W S
 S

Guide	Part Number	Description		
256	203C5262P001	GROMMET COMPRESSOR	4	4
258	871516P006	CLIP COMPRESSOR	4	4
260	200D5454G005	SUPPORT COMPRESSOR ASM	1	1
275	200D5132G005	CONDENSER ASM	1	1
283	221C7127P009	FRONT HOUSING CONTROL	1	1
500	238C2369P002	CLIP CONDENSER	4	4
501	238C2369P004	CLIP DOUBLE CONDENSER	4	4

▣ PARTES DE RAPIDO MOVIMIENTO/FAST MOVING PARTS