

SAMSUNG

SERIES **7**
7100

QUICK START GUIDE



BN68-05033A-00

Welcome to your new Smart TV!

The following instructions cover assembling, connecting, and setting up your new TV. Make sure you have the accessories listed below.

Included in this box

Remote Control



Smart Touch Control



Batteries (AAA x 2)

Stand Parts and Cables



Power cord



Cable manager

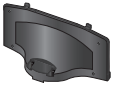

Stand Mount



IR extender

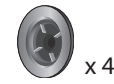

Wall mount adapter

Attach the TV to the Stand

Step 1

Connect video devices

Step 2

Insert the batteries into the remote control

Step 3

Power on and start the initial setup

Step 4

Warning: Screens can be damaged from direct pressure when handled incorrectly. We recommend lifting the TV by the edges, as shown.

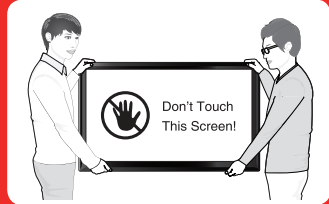

Also included: Cleaning cloth, user manual, regulatory guide, 3D Active Glasses

Step 1 Attach the TV to the Stand



Lay the TV on a soft surface, screen side down. Use the packing material to protect the screen.

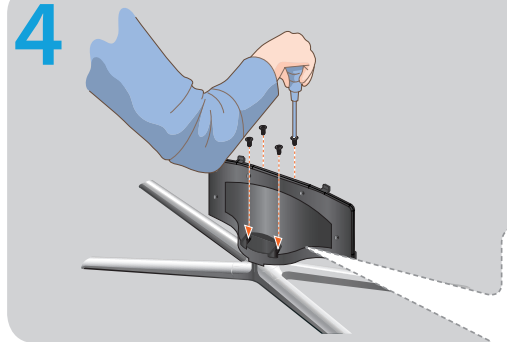

Insert 4 screws and secure the stand to the mount.

- x4 (M4 X L12) 40" ~ 55"
- x4 (M4 X L10) 60" ~ 65"

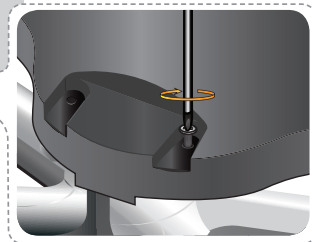

REQUIRED TOOLS: a Phillips head screwdriver and a soft, flat surface larger than the TV (such as the box).

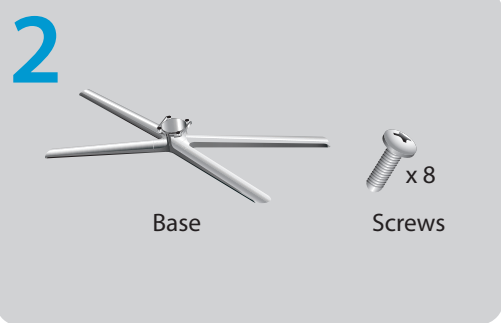

Put a base and screws off to assemble the stand out of the box.



Holding the stand parallel to the screen, slide the stand into the notches on the back of the TV.

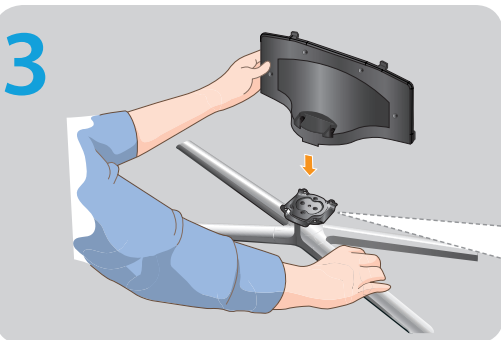
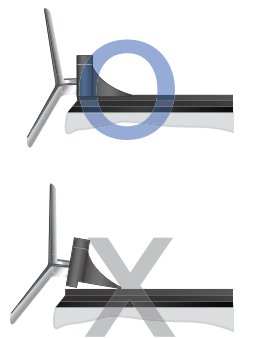
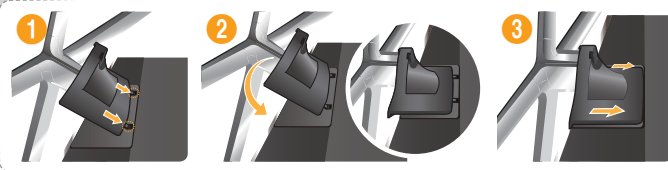

Fit the stand and mount together, making sure the notch on the mount aligns with the stand.

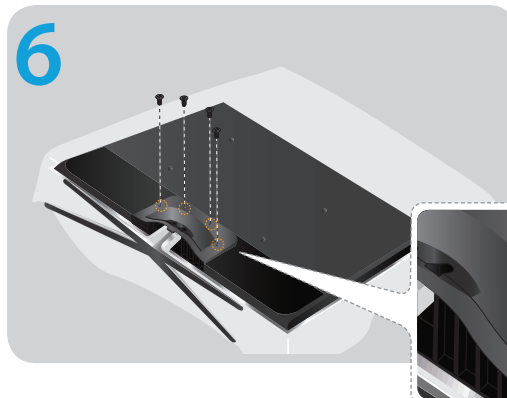

Insert 4 screws and secure the stand to the TV.

- x4 (M4 X L12) 40" ~ 55"
- x4 (M4 X L10) 60" ~ 65"

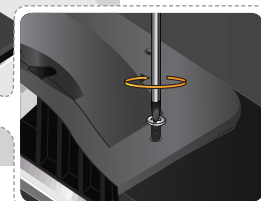

Step 2 Connect video devices

We suggest using HDMI connections whenever possible for the best picture quality.

The displayed image may differ depending on the model.

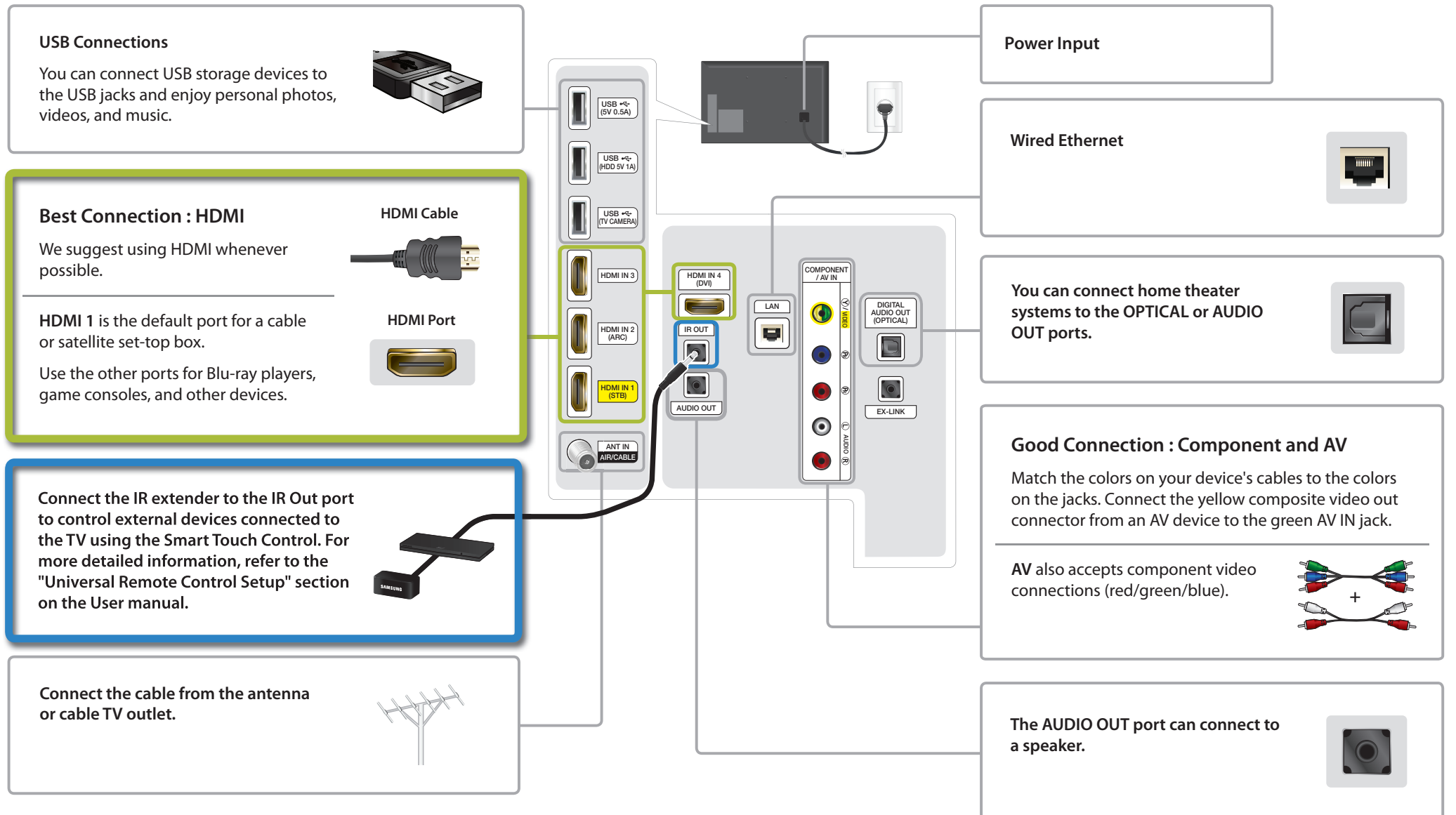

Step 3 Insert the batteries into the remote control

To open, put your plastic card into the notch.



Make sure you have the correct cable before plugging it in. Illustrations of common plugs and jacks are shown below.

	Cable Plugs	Ports / Jacks
HDMI		
USB		
Optical		

Warning Do not plug cables in upside down. Be sure to check the orientation of the plug before plugging it in.

Step 4 Power on and start the initial setup

Information required:

- Wi-Fi network password (if you use one)
- Zip code
- Cable or satellite provider info

The TV must be connected to the Internet to use the Smart Features. If you have a wireless network, we recommend that you confirm that your network router is switched on and working before you start the initial setup. If you have a wired network, we recommend that you connect the TV to the network with a CAT 7 cable before you begin.

Power on to start the initial setup.

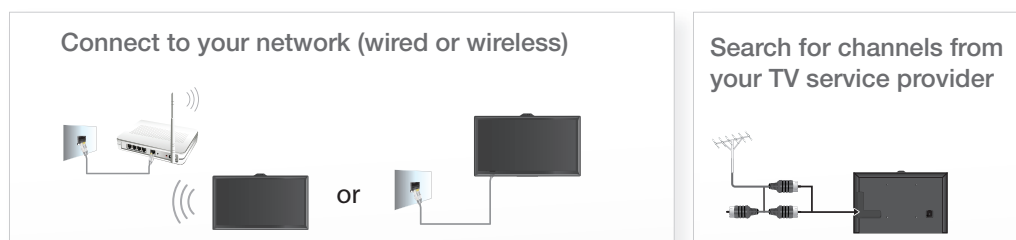

After you have finished the initial setup, you can configure the universal remote control settings. These settings let the Smart Touch remote control external devices connected to the TV, such as a set-top box or Blu-ray player.

Troubleshooting

The stand is wobbly or crooked

Make sure the arrows on the stand are properly aligned.

The TV won't turn on

Make sure all cables are fully inserted, and that the remote has batteries installed.

My remote, gesture, or voice controls don't work

The TV ships with protective stickers covering some of the sensors. Make sure all of them have been removed.

I have extra parts

The TV includes some optional parts to help with wall mounting and cable routing.



Congratulations on your new Smart TV!