

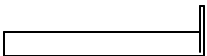

Installation & Assembly

Microwave Oven Bracket Installation Instruction

(Only to be used in models MO699SST-1/MO7080MW/MO7090MB/M07180TW/MO7280TB installation)

Parts List & Hardware	Before you start this installation make sure you have all the parts listed below. Read entire installation sheet before you start assembly of this item.			
Microwave Oven Models	MO699SST-1/MO7080MW/MO7090MB/M07180TW/MO7280TB			
	Part Number	Qty	Description	
A	MOM9704	1	Mounting Bracket	
B	9704-001	2	Locking Pin	
C	9704-002	3	No. 8 x 5/8" Phillips Hex Head Self Tapping Screw	
D	9704-003	4	No. 8 x 1" Phillips Pan Head Sheet Metal Screw	
E	9704-004	4	Plastic Anchor (1/4" x 1")	

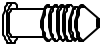
Installation Procedures:

1) Bracket Configuration:

Holes (A), (B) and (C) are the existing holes in the upper part of the Metal bracket. Holes (D), (E), (F) and (G) are also existing holes in the lower part of the Metal bracket.

See illustration #1.

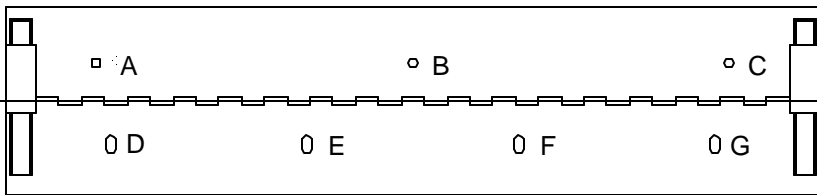

Illustration # 1

2) Installation of the upper side of the Metal bracket to the Microwave:

Place top of the bracket on the back of the microwave. Insert one of the (3) Phillips Hex Head Self Tapping screws provided into pilot hole (A) then proceed installing the remaining (2) two Phillips Hex Head Self Tapping screws into holes (B) and (C). Secure using a Phillips head screwdriver.

See illustration # 2.

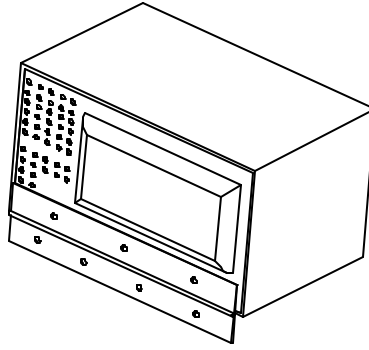

Illustration # 2

3) Installation of the lower side of the Metal bracket to the Refrigerator:

Lay and center the Microwave oven (with bracket installed) on top of the refrigerator.

Flip down the lower part of the bracket.

Using the four (4) existing holes on the bracket as a guide, mark the locations where to drill the holes (D), (E), (F) and (G). See illustration # 3.

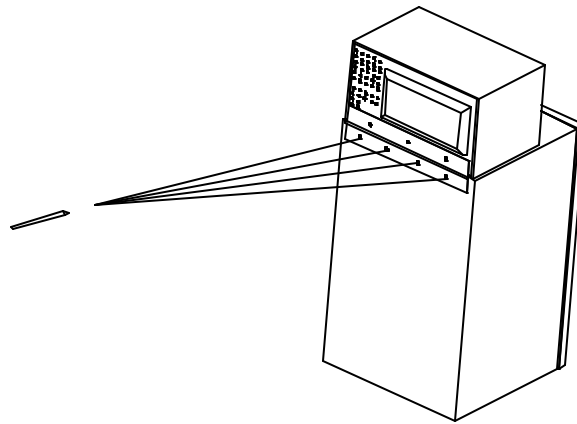

Illustration # 3

4) Drilling the four holes to the Refrigerator:

After marking the locations of the four (4) holes, remove the Microwave oven and bracket from the top of the refrigerator and proceed drilling the four (4) holes with a 1/4" drill bit into the rear of the Refrigerator. See illustration # 4.

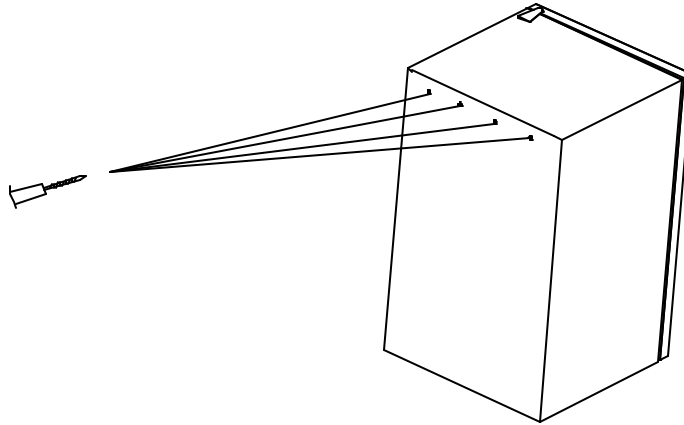

Illustration # 4

5) Inserting the Plastic Anchors to the Refrigerator:

Insert the four (4) Plastic Anchors provided into the four (4) holes (step 5) in the back of the refrigerator. See illustration # 5.

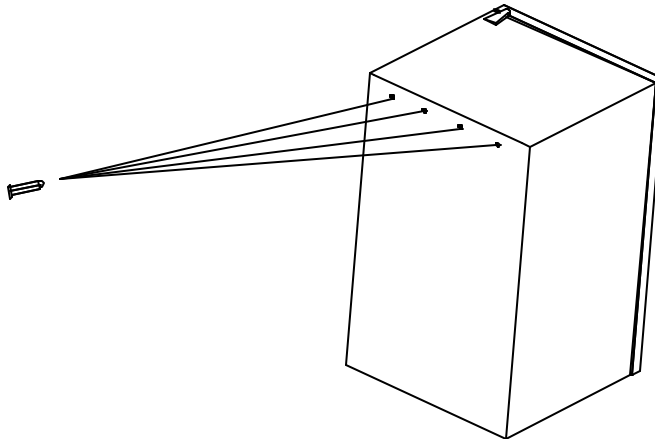

Illustration # 5

6) Completing the assembly:

Lay the Microwave oven with the metal bracket already installed on top of the refrigerator.

Align the four (4) holes of the lower part of the metal bracket to meet the four (4) plastic anchors installed in previous step 6.

Attach the lower part of the metal bracket to the refrigerator.

Secure with the four (4) Phillips Pan Head Sheet Metal screws (provided) using a Phillips head screwdriver.

7) Safety features :

For your Safety, this metal bracket comes with two Lock Pins that will prevent the Microwave oven from tilting back while in use. These two (2) Lock Pins (provided) can be lifted and removed to allow you to clean the refrigerator top.

It is recommended to have both Lock Pins installed once the refrigerator is cleaned. See illustration # 6.

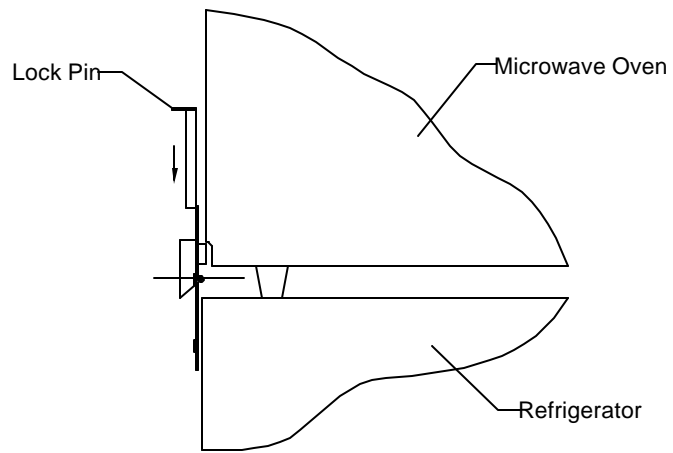

Illustration # 6