



LASTS AND LASTS AND LASTS.®

2-STAGE HEAT/2-STAGE COOL OR HEAT PUMP THERMOSTAT

7-Day, 5-2 Day & 5-1-1 Day Programmable

2246008

AMANA BRAND QUALITY

Americans have been relying on long-lasting Amana brand products since 1934, when Amana, Iowa, native George Foerstner accepted the challenge of building a dependable beverage cooler. Since then, the Amana brand has enjoyed many firsts, including developing the first cold storage locker, being the first manufacturer to nationally market an upright freezer for home use, and introducing the first portable countertop microwave oven.



- 2-Stage Heat/2-Stage Cool
- 2-Stage Heat Pump
- Patented Thermal Intrusion Barrier
- Large Display with Backlight
- Permanent Memory
- Accuracy: $\pm 1^{\circ}\text{F}$, $\pm 0.5^{\circ}\text{C}$
- Programmable Fan Mode
- Manual or Auto Changeover
- Field Adjustable Calibration
- Hardwired
- Extra Comfort and Energy Savings Modes Between Stages

FEATURING:

- Premium Amana® brand Quality



Hardwired



R C W1/O/B Y1 W2 Y2 G S1 S2

- Adjustable Maximum Heat/Minimum Cool Setpoints
- Adjustable Temperature Differential
- Configurable Remote Sensor Compatible
- Selectable $^{\circ}\text{F}$ or $^{\circ}\text{C}$
- Keypad Lockout
- Soft Touch Controls

www.amana-PTAC.com

2246008

PROGRAMMABLE THERMOSTAT

7-DAY, 5-2-DAY & 5-1-1-DAY

2-STAGE HEAT/2-STAGE COOL OR HEAT PUMP

Hardwired



- 2-Stage Heat/2-Stage Cool
- Compressor Heat Pump
- Large Display with Backlight
- Field Temperature Calibration



Dimensions:

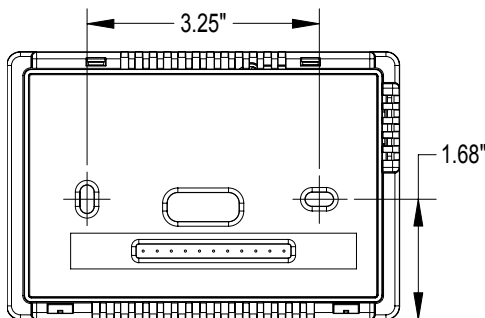
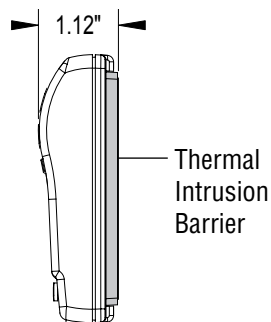
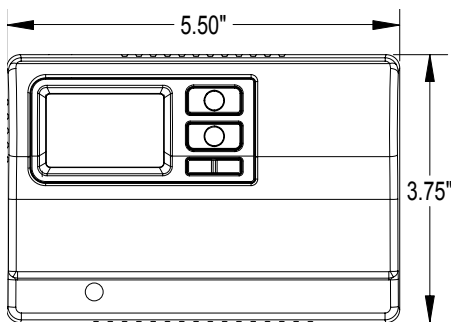

Specifications:

Electrical Rating:

- 24 VAC (18-30 VAC)
- 1 amp maximum per terminal
- 3 amp maximum total load
- Easy access terminal block

Temperature Control Ranges:

- 45°F to 90°F, Accuracy: $\pm 1^\circ\text{F}$
- 7°C to 32°C, Accuracy: $\pm .5^\circ\text{C}$

System Configurations:

- 2-stage heat/2-stage cool

Terminations: R, C, W1/O/B, Y1, W2, Y2, G, S1, S2

Other Amana® brand thermostats available:

2246002

- 1-Stage Heat/1-Stage Cool
- 1-Stage Heat Pump
- 4- or 5-Wire Compatible (C is Optional for Non-Heat Pump Systems)
- Manual Changeover



2246003

- 2-Stage Heat/1-Stage Cool Heat Pump
- Manual Changeover



2246007

- 2-Stage Heat/Cool or 2-Stage HP
- Large Display with Backlight
- Field Temperature Calibration



Heating & Air Conditioning
Amana
LASTS AND LASTS AND LASTS.®

Patent No. Design: 424,953

Patent No. Thermal Intrusion Barrier: 6,597,275

Patented - SimpleSet™ Target Programming Technology: 7,575,179B2

Specifications subject to change without notice.

www.amana-PTAC.com

Our continuing commitment to quality products may mean a change in specifications without notice. © 2012 Goodman Company, L.P. Amana is a registered trademark of Maytag Corporation or its related companies and is used under license to Goodman Company, L.P., Houston, TX. USA. All rights reserved.

PM-PSAT-008 10-12