



48" Signature Series Freezer/Refrigerator Specification Sheet

Model Nos.

- HP48FR-B
- HP48FR-S



HP48FR-S-5-5



HP48FR-S-IL-1R

Features:

- Multi-zone, Multi-door undercounter refrigeration unit: Available in two temperature zones
- Designed with fully-integrated depth to allow flush fit with surrounding cabinetry (with 3/4" wood overlay)
- Zero-clearance hinging allows for abutment with surrounding cabinetry
- Perlick's exclusive Variable Speed Compressor
- Front-vented, forced-air refrigeration
- Industry Exclusive full-extension shelving
- Industry Exclusive stainless steel interior
- Two (2) year full warranty on complete unit – Additional four year limited warranty on the sealed refrigeration system
- Maintenance-free automatic defrost cycle
- Industry Exclusive Convertible Door Design allows all doors to be converted to wood overlay from stainless steel
- Low E, UV coated glass provides industry leading insulation and protection
- Doors lock available
- Interior digital display
- 12 cubic feet of capacity

48" freezer/refrigerator features:

- Freezer equipped with automatic hot gas defrost for maintenance-free defrosting
- Refrigerator rated for both food and beverage storage
- Door locks prevent unwanted access
- Adjustable full-extension shelving allow easy storage and access to goods
- Door options for each compartment include solid stainless steel door, two (2) stainless steel drawers, glass door (refrigerator only), glass door with wood overlay (refrigerator only) or with solid wood overlay
- Freezer temperature - 10 – 10 degrees F
- Refrigerator temperature 33 – 39 degrees F

Luxury YOU DESIRE.
INNOVATION YOU CAN'T LIVE WITHOUT.



8300 W. Good Hope Rd. • Milwaukee, WI 53223

1-800-558-5592 • Fax: (414) 353-7069 • www.Perlick.com

Perlick is committed to continuous improvement. Therefore, we reserve the right to change specifications without warning

Indoor Models	Freezer/Refrigerator
HP48FR-B	48" freezer/refrigerator – built-in
HP48FR-S	48" freezer/refrigerator – freestanding

Job _____
 Area _____
 Item No. _____
 Model No. _____

Freezer Door Options
1 – solid stainless door (Left or Right hinge)
2 – solid wood overlay door (Left or Right hinge)
5 – solid stainless steel drawers
6 – solid wood overlay drawers

Refrigerator Door Options
1 – solid stainless door (Left or Right hinge)
2 – solid wood overlay door (Left or Right hinge)
3 – stainless glass door (Left or Right hinge)
4 – wood overlay glass door (Left or Right hinge)
5 – solid stainless steel drawers
6 – solid wood overlay drawers

Overall Width: 47-7/8", 121.603 cm
Overall Height: 34-5/16", 87.154 cm
Overall Depth: 23-15/16", 60.801 cm
Capacity: 12 cubic ft.
Minimum Height Required: 34-3/8"
Door Swing Clearance: 24-25/32"
Electrical: 115V, 60 Hz., 1 phase AC, 2.3 amps
Plumbing: none required
Shipping Weight: 360 lbs.

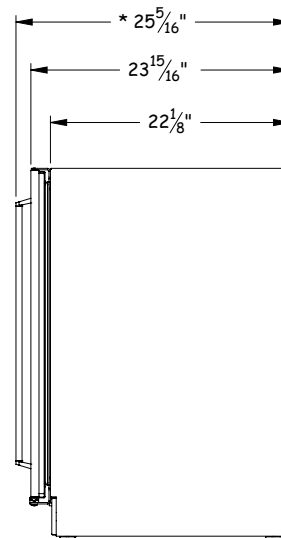
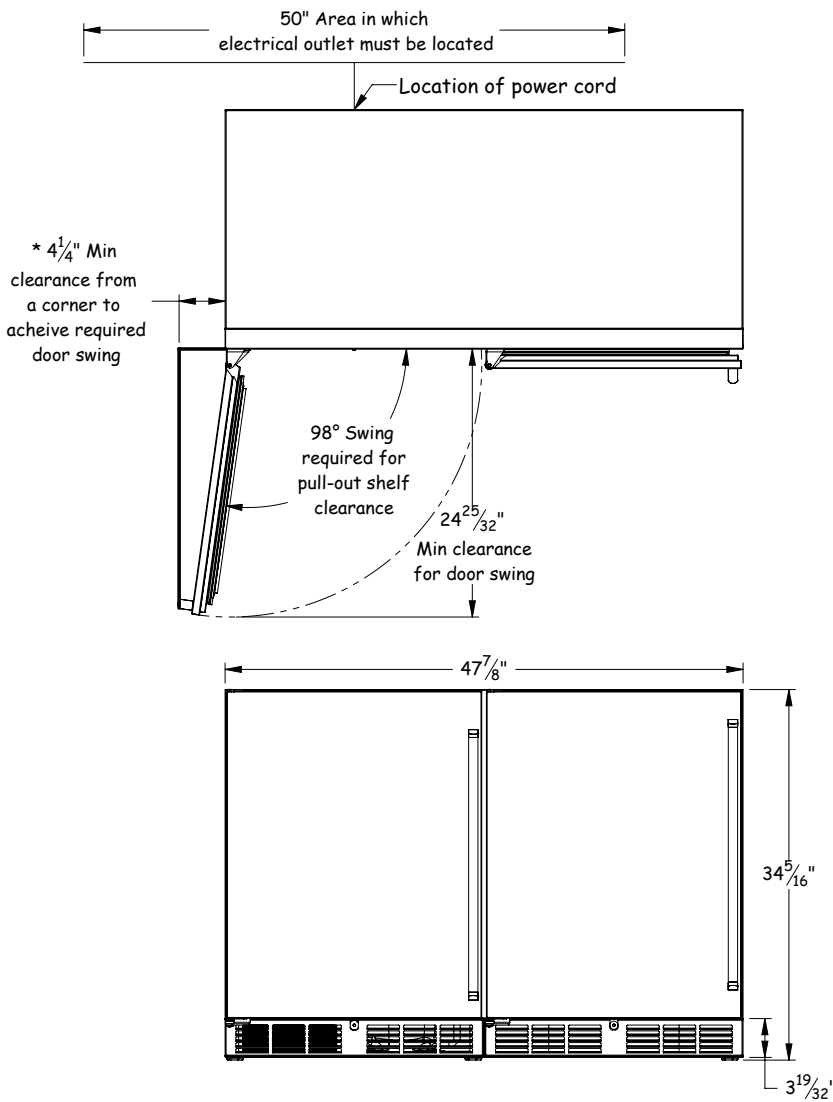
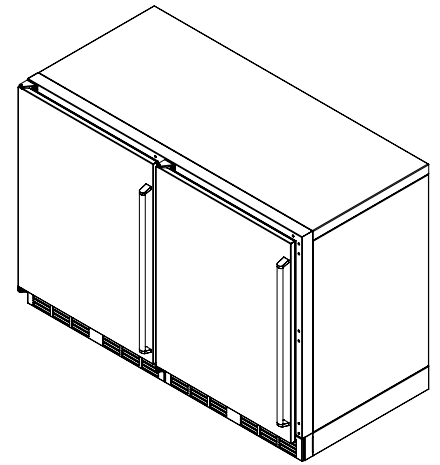

* - Values may change due to custom pull with a wood overlay door



8300 W. Good Hope Rd. • Milwaukee, WI 53223

1-800-558-5592 • Fax: (414) 353-7069 • www.Perlick.com

Perlick is committed to continuous improvement. Therefore, we reserve the right to change specifications without warning