

Owner's Manual

30" Built-In
Bottom-Freezer
2-Drawer
Refrigerator

197D8243P001

49-60615

08-10 GE

monogram.com



Introduction

Your new Monogram Refrigerator makes an eloquent statement of style, convenience and kitchen planning flexibility. Whether you chose it for its purity of design or the assiduous details, you will find that your Monogram Refrigerator's superior blend of form and function will delight you for years to come.

The information on the following pages will help you operate and maintain your Refrigerator properly. If you have any other questions, visit our Website at: monogram.com

Contents

Consumer Services

Important Phone Numbers23
 Model and Serial Numbers3
 Performance Data Sheet19
 Problem Solver17, 18
 Safety Instructions 4, 5
 State of California Water
 Treatment Device Certificate20
 Warranty Back Cover

Care and Cleaning

Cleaning—Outside and Inside14
 Light Bulb Replacement 15
 Vacation15

Operating Instructions

Features6
 Automatic Icemaker8
 Customizable Drawer 11
 Door Bins 11
 External Moisture Control12
 LED Display Lighting12
 Sabbath Mode13
 Shelves10
 Temperature Controls7
 Vegetable Pan10
 Water Filter9
 Wine/Beverage Rack11

Preparation

Clearances16
 Location16

Before using your refrigerator

Read this manual carefully. It is intended to help you operate and maintain your new refrigerator properly.

Keep it handy for answers to your questions.

If you don't understand something or need more help, there is a list of toll-free consumer service numbers included in the back section of this manual.

OR

Visit our Website at: monogram.com

Consumer Information

30" Bottom-Freezer

*Write
down the
model &
serial
numbers*

You'll see them on a label inside the fresh food compartment, below the vegetable pan.

Before sending in this card, please write these numbers here:

Model Number

Serial Number

Use these numbers in any correspondence or service calls concerning your refrigerator.

*If you
received a
damaged
refrigerator*

The warranty does not cover damage caused after delivery.

Immediately contact the dealer (or builder) that sold you the refrigerator.

*Save time
& money*

Before you request service, check the Problem Solver in the back of this manual.

It lists causes of minor operating problems that you can correct yourself.

*If you
need
service*

To obtain service, see the Consumer Services page in the back of this manual.

We're proud of our service and want you to be pleased. If for some reason you are not happy with the service you receive, here are steps to follow for further help.

FIRST, contact the people who serviced your appliance. Explain why you are not pleased. In most cases, this will solve the problem.

NEXT, if you are still not pleased, write all the details—including your phone number—to:

Manager, Customer Relations
GE Appliances
Appliance Park
Louisville, KY 40225

IMPORTANT SAFETY INSTRUCTIONS

READ AND SAVE THESE INSTRUCTIONS

⚠ WARNING—When using this appliance, always exercise basic safety precautions, including the following:

- **Use this appliance only for its intended purpose** as described in this Owner's Manual.
- **This refrigerator must be properly installed in accordance with the Installation Instructions before it is used.**
- **Do not allow children to climb, stand or hang on the door bins in the refrigerator.** They could damage the refrigerator and seriously injure themselves.
- **Do not touch the cold surfaces in the freezer compartment when hands are damp or wet.** Skin may adhere to these extremely cold surfaces.
- **Do not store or use gasoline or other flammable vapors and liquids in the vicinity of this or any other appliance.**
- **Your freezer has an automatic icemaker in the freezer drawer**—avoid contact with the moving parts of the ejector mechanism, or with the heating element located on the bottom of the icemaker. Do not place fingers or hands on the automatic icemaking mechanism while the freezer is plugged in.
- **Turn off the circuit breaker to disconnect power when cleaning or making repairs.** Repairs should be made by a qualified service technician.
- **Do not try to replace a burned-out LED light.** An authorized technician will need to replace the LED lights.
- **Do not refreeze frozen foods which have thawed completely.**

DANGER: RISK OF CHILD ENTRAPMENT

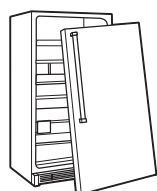

Child entrapment and suffocation are not problems of the past. Junked or abandoned refrigerators are still dangerous...even if they will sit for "just a few days." If you are getting rid of your old refrigerator, please follow these instructions to help prevent accidents.

Before You Throw Away Your Old Refrigerator:

- Take off the door/drawers.
- Leave the shelves in place so that children may not easily climb inside.

REFRIGERANTS

All refrigeration products contain refrigerants, which under federal law must be removed prior to product disposal. If you are getting rid of an old refrigeration product, check with the company handling the disposal about what to do.

⚠ WARNING—R600a Refrigerant

Warning: This appliance contains isobutane refrigerant, R600a, a natural gas with high environmental compatibility. However it is also combustible. Please adhere to the warnings below:

- 1) When handling, installing and operating the appliance, care should be taken to avoid damage to the refrigerant tubing.
- 2) Servicing shall be performed by factory-authorized service personnel and component parts shall be replaced with manufacturer-authorized replacement components.
- 3) Refrigeration products contain refrigerants, which under federal law must be removed prior to product disposal.
- 4) Keep ventilation openings in the appliance enclosures or in the built-in structure clear of obstruction.
- 5) Do not use mechanical devices or other means to accelerate the defrosting process.
- 6) Do not damage refrigerant circuit.
- 7) Do not use electrical appliances inside the food storage compartment of the appliance.

IMPORTANT SAFETY INSTRUCTIONS

HOW TO CONNECT ELECTRICITY

Do not, under any circumstances, cut or remove the third (ground) prong from the power cord. For personal safety, this appliance must be properly grounded.

The power cord of this appliance is equipped with a 3-prong (grounding) plug which mates with a standard 3-prong (grounding) wall outlet to minimize the possibility of electric shock hazard from this appliance.

Have the wall outlet and circuit checked by a qualified electrician to make sure the outlet is properly grounded.

Where a standard 2-prong wall outlet is encountered, it is your personal responsibility and obligation to have it replaced with a properly grounded 3-prong wall outlet.

The refrigerator should always be plugged into its own individual electrical outlet which has a voltage rating that matches the rating plate.

DO NOT USE AN ADAPTER PLUG TO CONNECT THE REFRIGERATOR TO A 2-PRONG OUTLET.

DO NOT USE AN EXTENSION CORD WITH THIS APPLIANCE.

This provides the best performance and also prevents overloading house wiring circuits, which could cause a fire hazard from overheated wires.

Never unplug your refrigerator by pulling on the power cord. Always grip plug firmly and pull straight out from the outlet.

Repair or replace immediately all power cords that have become frayed or otherwise damaged. Do not use a cord that shows cracks or abrasion damage along its length or at either end.

When moving the refrigerator away from the wall, be careful not to roll over or damage the power cord.

**SAVE THESE
INSTRUCTIONS**

Features

30" Bottom-Freezer

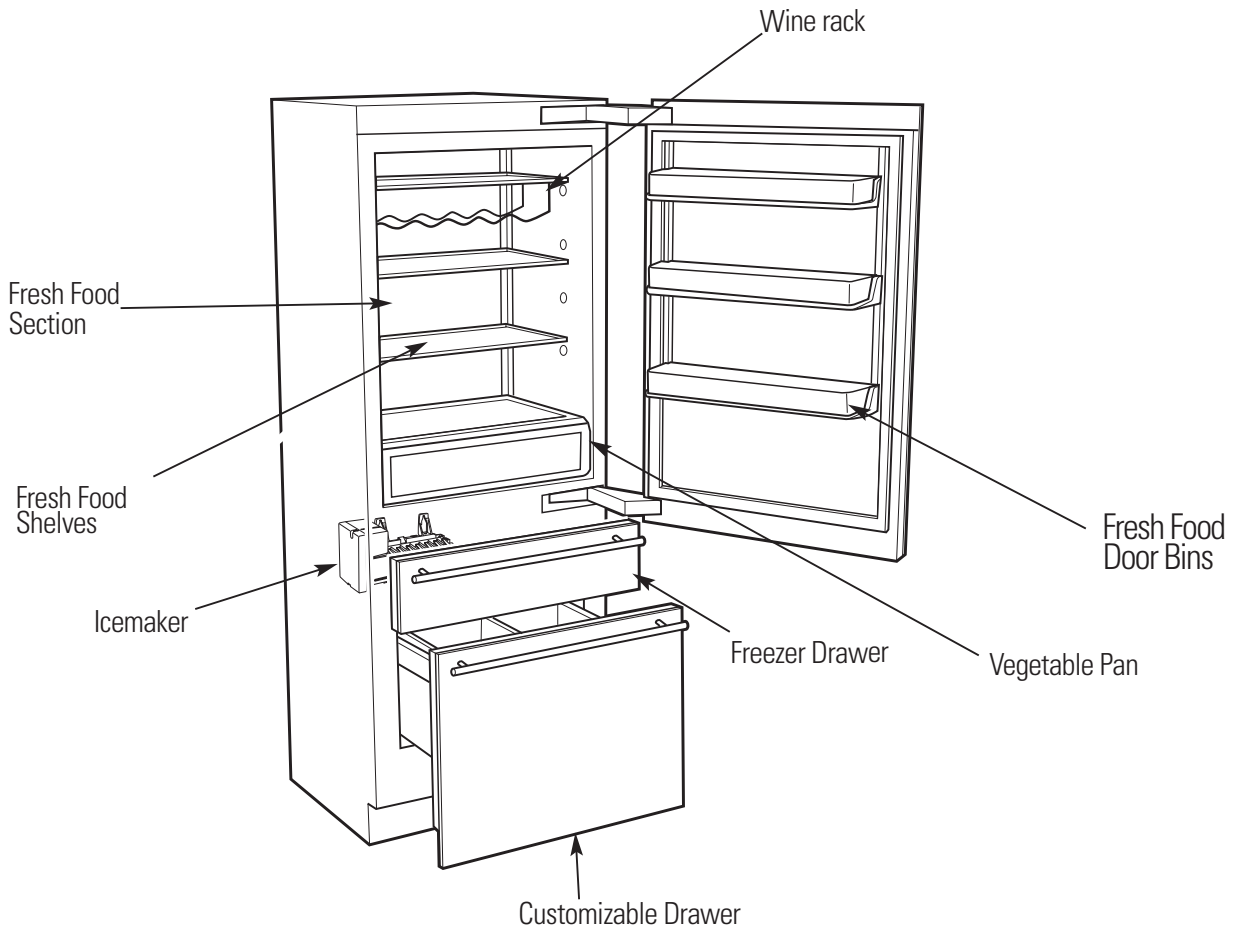

Temperature Controls

30" Bottom-Freezer

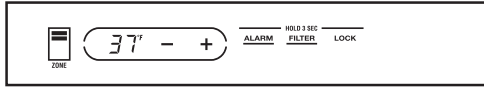

Fresh Food – Solid Door Unit

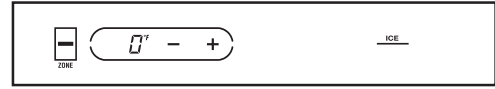

Upper Drawer – Freezer

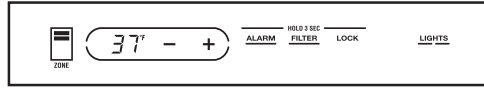

Fresh Food – Glass Door Unit

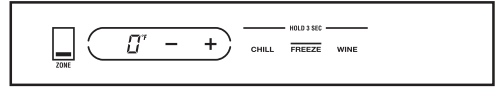

Lower Drawer – Customizable

Temperature controls

The temperature display shows the actual temperature of the fresh-food compartment, freezer drawer or customizable drawer when each one is selected by toggling the Zone indicator. The actual temperature will vary from the set temperature based on factors such as frequency of door openings, amount of food, defrost cycling and room temperature.

NOTE: Frequent door openings or doors left open for periods of time may increase the internal temperature of the compartments temporarily.

To turn off the cooling system, toggle the **ZONE** indicator to the fresh-food mode. Press the plus (+) pad until the display shows **OFF**.

To turn the cooling system on, toggle the **ZONE** indicator to the fresh-food mode and press the minus (-) pad until the desired temperature is displayed. The preset temperature of 0°F for the freezer or 37°F for the fresh-food unit will appear in the display.

To check the current temperature setting for a compartment, press the plus (+) or minus (-) pad once. After 5 seconds, the display will return to the actual temperature.

To change the temperature settings, press the plus (+) or minus (-) pad for each increment to the desired temperature set point. Allow 24 hours for the unit to reach the temperature you have set.

Temperature Ranges

	Low	High
Fresh Food	34°F 1°C	46°F 8°C
Freezer Drawer	-6°F -21°C	+6°F -14°C

Customizable Drawer Temperature Ranges

	Low	High
Freezer	-6°F -21°C	+6°F -14°C
Chill	34°F 1°C	46°F 8°C
Wine	40°F 4°C	55°F 13°C

NOTE: Setting the controls to **OFF** stops cooling, but **does not** shut off electrical power to the unit. All readings in °C will be rounded.

Changing display temperatures from °F to °C

To change the temperature display between Fahrenheit and Celsius, press both the plus (+) and minus (-) pads for 5 seconds.

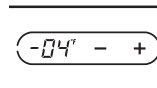

Alarm

To turn the Alarm feature on, press and hold the **ALARM** button for 3 seconds. **ALARM** will be underlined when active. To turn off, press and hold the **ALARM** button for 3 seconds. The underline will disappear.

When the **ALARM** is active, the alarm will flash and beep if you keep the door open for more than 2 minutes.

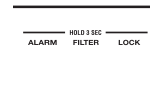

Automatic Ice maker (freezer models)

30" Bottom-Freezer

Automatic ice maker

A newly installed refrigerator may take 12–24 hours to begin making ice. The refrigerator is shipped with the icemaker set to ON.

The icemaker will produce seven cubes per cycle—approximately 15 cycles in a 24-hour period, depending on freezer compartment temperature, room temperature, number of door openings and other use conditions.

If the refrigerator is operated before the water connection is made to the icemaker, set the icemaker to **OFF**. To set the icemaker to OFF, press the **ZONE** indicator on the control pad twice to select the freezer drawer. Press the **ICE** icon to the right. The line under **ICE** will disappear and the word **OFF** will show under **ICE**.

Throw away the first full bucket of ice.

Be sure nothing interferes with the sweep of the feeler arm.

When the bin fills to the level of the feeler arm, the icemaker will stop producing ice.

It is normal for several cubes to be joined together.

If ice is not used frequently, old ice cubes will become cloudy, taste stale and shrink.

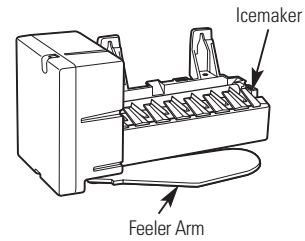

After the icemaker has been turned on again, there will be a delay of about 45 minutes before the icemaker resumes operations.

NOTE: In homes with lower-than-average water pressure, you may hear the icemaker water valve cycle on several times when making one batch of ice.

NOTE: Icemaker works best between 40 and 120 PSI home water pressure.

Accessing the icemaker and freezer drawer

The icemaker is located on the ceiling of the freezer drawer and to the left rear. There is an LED strip in the freezer drawer ceiling. The freezer drawer contains 1 ice bin.

Water Filter

30" Bottom-Freezer

Water filter cartridge

The water filter cartridge is located below the customizable drawer on the lower-right side of the appliance.

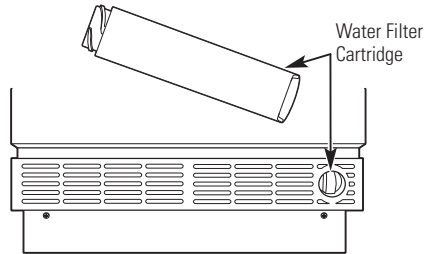

To Replace the Filter:

While the filter cartridge may last up to 1 year, replacement frequency will depend on ice usage. There is a replacement indicator light for the water filter cartridge on the control panel. The filter cartridge should be replaced when the word **REPLACE** appears beneath **FILTER** on the control panel.

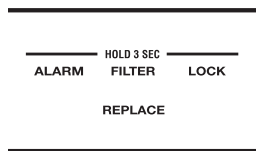

Installing the Filter Cartridge:

1. Open the customizable drawer to gain access to the water filter cartridge.
2. Remove the old cartridge by twisting counterclockwise. Pull forward on the filter to remove.
3. Insert the new filter into the compartment and twist clockwise until the cartridge stops.

To Reset the Filter Status Light:

Press and hold the **FILTER** button for 3 seconds.

Filter Bypass Plug:

You **must** use the filter bypass plug if:

- a) you have a household reverse osmosis water system and/or another form of home water filtration system.
- b) a replacement filter is not available.

The icemaker will not operate without the filter or filter bypass plug installed.

The bypass plug and mini manual are located in the bottom machine compartment.

Replacement filters:

To order additional filter cartridges, visit our Website at monogram.com, or call GE Parts and Accessories, 800.626.2002.

Filter Model Number GSWF

IMPORTANT NOTE: Remove the water filter to immediately stop any water leak from the icemaker.

Child control lockout

This child control lockout feature prevents unwanted changes to your temperature settings.

After the desired temperature is set, the temperature can be locked. To lock, press and hold the **LOCK** button for 3 seconds. To unlock, press and hold the **LOCK** button for 3 seconds.

Vegetable pan

The Vegetable Pan in the fresh-food section of the refrigerator has LED strip lighting above the drawer.

There are adjustable dividers with several different position options. The divider is held in place by a tab located under the handle, a slot located on the back wall and a stabilizing rib on the bottom of the drawer for each position.

To change the divider position:

1. Pull up on the back of the divider to release it from the slot in the back and off of the tab in the front.
2. Slide the divider into a new location, making sure it seats into the rib on the bottom of the drawer.
3. Pull up on the back of the divider to locate the front under the tab at the new location.

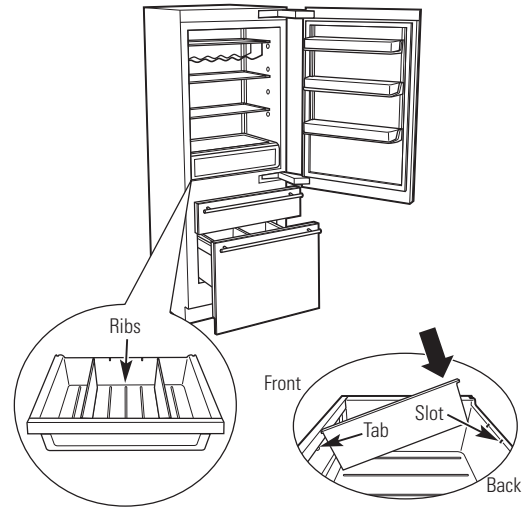

4. Push down on the back of the divider to seat it into the slot at the new location.

Lighted vegetable drawer shelf

The lighted vegetable drawer shelf provides lighting for the lower compartments. The lights are recessed into the shelf to illuminate the drawers below.

To remove the shelf:

1. Lift the shelf and carefully pull forward to expose the wires.
2. Unplug the shelf and carefully remove it from the refrigerator.

To replace the shelf:

1. Carefully set the shelf onto the side rails, leaving the plug exposed.
2. Plug the shelf into the refrigerator.
3. Carefully slide the shelf into place.

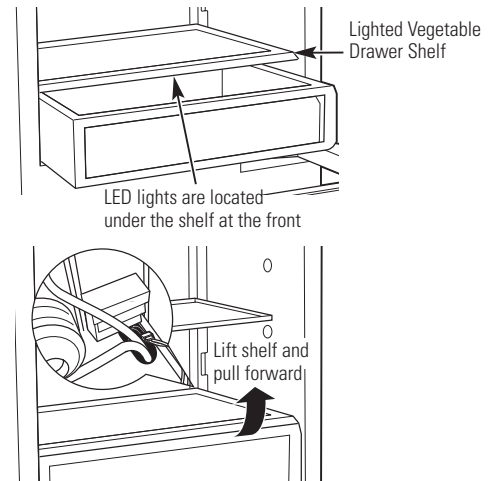

Adjustable shelves

Tempered glass shelves in the fresh food section enable you to make efficient shelf arrangements to fit your family's food storage needs.

To adjust shelves: Tilt the shelf up at the front and slide it up or down along the back wall to the placement you want.

Handle glass shelves carefully. Rough handling of tempered glass can cause it to shatter.

To remove shelves:

NOTE: To remove a shelf, all shelves under it must first be removed.

1. Remove any food from the shelf
2. Remove covers at the bottom of each track.
3. Tilt the first shelf up at the front.
4. Slide the shelf down along the back wall until you reach the bottom where the notch is located. Slide the shelf through the notch.

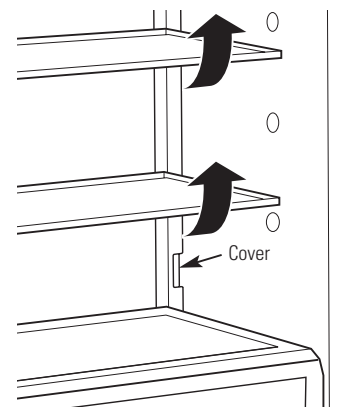

5. Repeat for removing the other shelves.

To replace shelves:

Replace shelves by perform steps 1 through 4 in reverse.

Door bins

The door bins are removable. Lift bin out of the bin bracket to remove.

The bin brackets are adjustable and can move up and down to meet your storage needs.

Do this by tilting the bin up at the front and sliding it up or down along the door to the placement you desire.

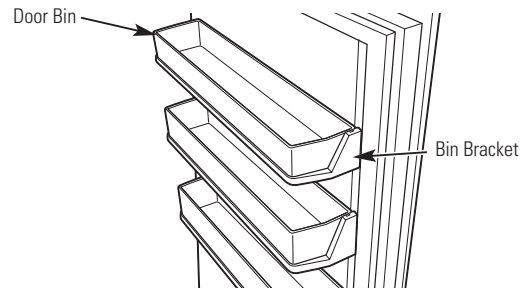

Wine/ beverage rack

The wine/beverage rack fits onto one of the glass shelves in the fresh-food compartment. The rubber coating on the portions of the rack that sit on top of the shelf keeps the rack from slipping or scratching the shelf. The wine/beverage rack will hold 2-liter bottles, wine bottles and champagne bottles.

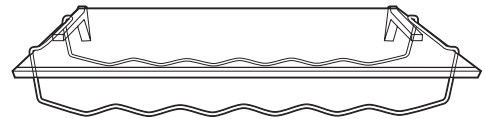

Customizable drawer

The customizable drawer can be used as a freezer, as a fresh-food refrigerator or as a wine/beverage drawer.

To customize your drawer:

Press the **ZONE** indicator on the control pad to select the customizable drawer.

Recommended Temperatures for Customizable Drawer:

Button	Function	Temperature
Chill	Fresh Food	37°F/3°C
Freeze	Freezer	0°F/-18°C
Wine	Wine Storage	55°F/13°C

This drawer has LED strip lighting above it. There is also one adjustable divider that can be placed in different positions and a bin that can slide left or right in the drawer.

To change the divider position:

1. Pull in the tabs at the top of the divider to release it from the tab holes at the front and back of the drawer.
2. Lift the divider off of the raised tabs at the bottom of the drawer.
3. Move the divider to its new location and slide it onto the raised tabs.
4. Pull in the tabs at the top of the divider and position the divider so the tabs will fit into the tab holes. Release the tabs so they lock into place.

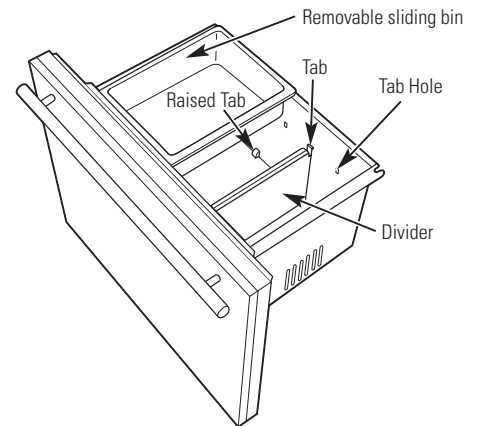

External moisture control

This product is equipped with an external moisture control feature. The refrigerator is shipped with the external moisture control feature off.

In some humid environments, moisture can form on the front surface of the refrigerator cabinet. If moisture does appear on the front surface of the refrigerator cabinet, turn on the external moisture control feature by pressing and holding the **ALARM** and **LOCK** buttons on the control panel for 5 seconds. When activated, a small picture of a water droplet with a line through it will appear below the **(+)** and **(-)** signs on the control panel.

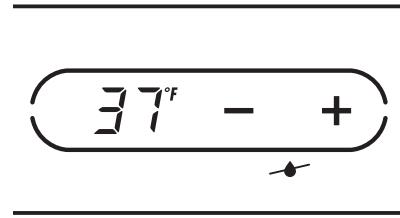

LED display lighting

This refrigerator has LED lighting on both sides of the interior as well as above the freezer drawer and above the customizable drawer.

Glass Door Models Only

The glass door models have a display light option for the interior side lights: full power and 1/2 power.

In display mode at either full or 1/2 power, the lights will stay on after the door is closed and automatically go off after 1 hour.

To access the lighting options, press the **ZONE** indicator on the control pad. In fresh-food mode, the **LIGHTS** button is to the right on the control pad. When lights are at full power, there are 2 bars under **LIGHTS**; at 1/2 power, there is 1 bar; when the lights are off, there are no bars.

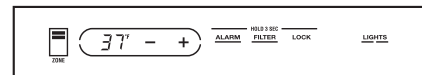

Glass Door Model – Lights at Full Power

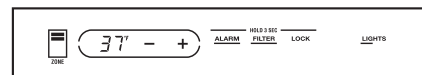

Glass Door Model – Lights at 1/2 Power

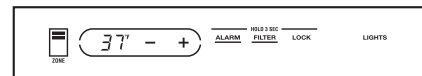

Glass Door Model – Lights Off

Sabbath Mode

30" Bottom-Freezer

Sabbath Mode

The Sabbath Mode was designed for use on the Jewish Sabbath and Holidays. The Sabbath Mode feature makes it possible for observant Jews to refrigerate and freeze food during the duration of the holiday.

The Sabbath Mode feature can be set to override typical reactions caused by your interaction with the refrigerator. While in the Sabbath Mode, your refrigerator will still operate. However, the refrigerator will not respond to your actions.

While in the Sabbath Mode, you may notice the fan running when the door is opened, however, this is not a result of your actions. The fan will operate at predetermined times. The defrost heater will continue to defrost the refrigerator and freezer and will be activated on a timer. The defrost heater will not defrost as a result of door openings or any consumer actions.

ON/OFF—To activate the Sabbath Mode, hold down the **ALARM** button and **(+)** pad on the control panel for 5 seconds. **SAB** will be displayed on the control. **SAB** will remain in the display and the **(+)** pad and alarm button will remain lit until the Sabbath mode is deactivated. Controls and lights do not work until the **ALARM** button and **(+)** pad are held again for 5 seconds.

DISPLAYS, ALARMS and LIGHTS—The main temperature control displays will be deactivated, therefore they will not be lit, sound a tone or operate when touched. Door alarms and lights will be disabled.

ICEMAKER—The icemaker will continue to operate. The icemaker can be disabled by turning the icemaker **OFF** prior to the Sabbath (see *Automatic Icemaker*).

Care and Cleaning

30" Bottom-Freezer

Cleaning outside

Door handles and trim—Clean with a cloth dampened with soapy water. Dry with a soft cloth.

Keep the outside clean. Wipe with a clean cloth lightly dampened with mild liquid dish detergent. Dry with a clean, soft cloth.

Do not wipe the refrigerator with a soiled dish cloth or wet towel. These may leave a residue that can damage the finish. Do not use scouring pads, powdered cleaners, bleach or cleaners containing bleach because these products can scratch and damage the finish.

Stainless steel—Regularly clean and polish the Stainless Steel Door Panels and Handles

(on some models) with a commercially available stainless steel cleaner such as *Stainless Steel Magic™* to preserve and protect the fine finish. *Stainless Steel Magic* is available through GE Parts and Accessories, 800.626.2002, or GEAppliances.com. Order part number WX10X15.

Do not use appliance wax or polish on the stainless steel.

Custom Wood Panels - please contact your custom panel supplier for direction on cleaning and care.

Cleaning inside

Turn off power at the circuit breaker or fuse box before cleaning. If this is not practical, wring excess moisture out of sponge or cloth when cleaning around switches, lights or controls.

Use warm water and baking soda solution— about a tablespoon (15 ml) of baking soda to a quart (1 liter) of water. This both cleans and neutralizes odors. Thoroughly rinse and wipe dry.

Other parts of the refrigerator—including door gaskets, vegetable drawer, ice storage bins and all plastic parts—can be cleaned the same way. After cleaning the door gaskets, apply a thin layer of petroleum jelly to the door gaskets at the hinge side. This helps keep the gaskets from sticking and bending out of shape.

Avoid cleaning cold glass shelves with hot water because the extreme temperature difference may cause them to break. Handle glass shelves carefully. Rough handling of tempered glass can cause it to shatter.

Do not wash any plastic parts in the dishwasher.

Care and Cleaning

30" Bottom-Freezer

Preparing for vacation

For long vacations or absences, remove food from the refrigerator. Adjust the temperature up **(+)** until the unit turns off. Clean the interior with a baking soda solution of one tablespoon (15 ml) of baking soda to one quart (1 liter) of water. Leave the door open.

For shorter vacations, remove perishable foods and leave the control at the regular setting. However, if the room temperature is expected to drop below 60°F (16°C), follow the same instructions as for extended vacations.

Turn off the icemaker and shut off the water supply to the freezer.

Interior Light replacement

Do not try to replace a burned-out LED light. An authorized technician will need to replace the LED lights.

Refrigerator location

Do not install the refrigerator where temperatures will be below 60°F (16°C) because it will not maintain proper temperatures, and the refrigerator could develop high internal humidity.

For proper installation, the refrigerator must be placed on a level surface of hard material the same height as the rest of the flooring. This surface should be strong enough to support a fully loaded refrigerator, or approximately 1,200 lbs. each. See the Installation Instructions for complete directions.

Clearances

Allow 15" minimum clearance between the door and wall for a full 115° door swing. Allow 5" min. clearance to a wall for a 90° door swing for Monogram Stainless Steel (European) models.

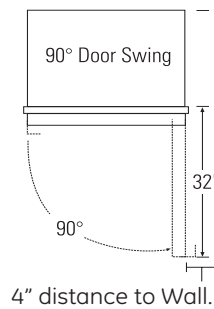
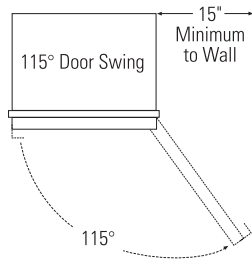

Questions?
Use this
problem
solver!

PROBLEM	POSSIBLE CAUSE
REFRIGERATOR SYSTEM DOES NOT OPERATE	<ul style="list-style-type: none"> • May be in defrost cycle when refrigerating system does not operate for about 45 minutes. • Temperature control in the OFF position. • If interior light is not on, refrigerator may not be plugged in at wall outlet. • The house fuse is blown/house circuit breaker is tripped. Replace fuse or reset the breaker. • Turn off the Sabbath Mode. • If your control panel says SHO, then your showroom mode was enabled. To turn this off, hold the ALARM button and (-) pad simultaneously for 5 seconds.
REFRIGERATING SYSTEM OPERATES FOR LONG PERIODS OR CYCLES ON FREQUENTLY (Modern refrigerators and freezers with more storage space and a larger freezer require more operating time. They start and stop often to maintain even temperatures.)	<ul style="list-style-type: none"> • Normal when refrigerator is first plugged in. Wait 24 hours for the refrigerator to completely cool down. • Often occurs when large amounts of food are placed in refrigerator. This is normal. • Door left open or package holding door open. • Hot weather or frequent door openings. This is normal. • Temperature control set at the coldest setting. See Temperature Control.
VIBRATION OR RATTLING (Slight vibration is normal.)	<ul style="list-style-type: none"> • Refrigerator may not be properly installed. <ul style="list-style-type: none"> – Anti-tip bracket may be loose. – Unit may not be level.
THUMPING SOUND WHEN CLOSING DOOR	<ul style="list-style-type: none"> • This is a normal operating sound. • Closing the door slowly will minimize the sound.
OPERATING SOUNDS	<ul style="list-style-type: none"> • The variable speed compressor. • Normal fan air flow—multiple fans blow cold air through the fresh-food and freezer compartments—other fans cool the compressor. • The fans change speeds in order to provide optimal cooling and energy savings. • These NORMAL sounds will also be heard from time to time: <ul style="list-style-type: none"> – You may hear a whooshing or gurgling sound when the door closes. This is due to pressure equalizing within the refrigerator. – A water dripping sound may occur during the defrost cycle as ice melts from the evaporator and flows into the drain pan. – The flow of refrigerant through the freezer cooling coils may make a gurgling sound like boiling water. – Water dropping on the defrost heater can cause a sizzling, popping or buzzing sound during the defrost cycle. – You may hear cracking or popping sounds when the refrigerator is first plugged in or during/after the defrost cycle. This happens as the refrigerator cools to the correct temperature. – The compressor may cause a clicking or chirping sound when attempting to restart (this could take up to 5 minutes). – The electronic control board may cause a clicking sound when relays activate to control refrigerator components. – Ice cubes dropping into the bin and water running in pipes as icemaker refills. – The icemaker water valve will buzz when the icemaker fills with water.

PROBLEM	POSSIBLE CAUSE
DOOR NOT CLOSING PROPERLY	<ul style="list-style-type: none"> • Package or bottle may be holding door open. • Check the door gasket; it may be out of position • Refrigerator is not level. See <i>Installation Instructions</i>. • Hinge springs deactivated. See <i>Installation Instructions</i>.
REFRIGERATOR TOO WARM	<ul style="list-style-type: none"> • Temperature control not set cold enough. See Temperature Control. • Hot weather or frequent door openings. • Door left open for long time. • Package may be holding door open.
ACTUAL TEMPERATURE NOT EQUAL TO SET TEMPERATURE	<ul style="list-style-type: none"> • Refrigerator just plugged in. Allow 24 hours for system to stabilize. • Door open for too long. Allow 24 hours for system to stabilize. • Warm food added to refrigerator. Allow 24 hours for system to stabilize. • Defrost cycle is in process. Allow 24 hours for system to stabilize.
FROST OR ICE CRYSTALS ON FROZEN FOOD (Frost within package is normal)	<ul style="list-style-type: none"> • Drawer left open or package holding door open. • Too frequent or too long door openings. • Drawer may have been left open. • Ice cubes or some other object may be stuck behind the drawer.
SLOW ICE CUBE FREEZING	<ul style="list-style-type: none"> • Drawer may have been left open. • Turn temperature control to a colder setting. • Package may be holding drawer open.
ICE CUBES HAVE ODOR/TASTE	<ul style="list-style-type: none"> • Old cubes need to be discarded. • Ice storage bin needs to be emptied and washed. • Unsealed packages in freezer may be transmitting odor/taste to ice cubes. • Interior of freezer needs cleaning. See Care and Cleaning. • Poor-tasting incoming water. Change the water filter.
AUTOMATIC ICEMAKER DOES NOT WORK	<ul style="list-style-type: none"> • Icemaker is turned off. • Water supply turned off or not connected. • Freezer too warm. • Piled up cubes in storage bin may cause icemaker to shut off too soon. Level cubes by hand. • Ice bin is not in position • Clogged water filter
MOISTURE FORMS ON OUTSIDE OF REFRIGERATOR	<ul style="list-style-type: none"> • Not unusual during periods of high humidity. Wipe surface dry. • Turn on the External Moisture Control feature.
MOISTURE COLLECTS INSIDE	<ul style="list-style-type: none"> • Too frequent or too long door openings. • In humid weather, air carries moisture into refrigerator when doors are opened. • Lower drawer switched from (freezer) to chill or wine.
REFRIGERATOR HAS ODOR	<ul style="list-style-type: none"> • Foods with strong odors should be tightly covered. • Check for spoiled food. • Interior needs cleaning. See Care and Cleaning.
INTERIOR LIGHTS DO NOT WORK	<ul style="list-style-type: none"> • No power at outlet. • LEDs need replacing. See Consumer Service Section. • The Sabbath Mode may be operating. Turn off Sabbath Mode.
DOOR DIFFICULT TO REOPEN IMMEDIATELY AFTER CLOSING	<ul style="list-style-type: none"> • Tight door seal is due to pressure equalizing within the refrigerator. After closing the door, wait 5–30 seconds to reopen.

Performance Data Sheet
SmartWater Filtration System
GSWF Cartridge

This system has been tested according to NSF/ANSI 42/53 for reduction of the substances listed below. The concentration of the indicated substances in water entering the system was reduced to a concentration less than or equal to the permissible limit for water leaving the system, as specified in NSF/ANSI 42/53.*
(100% safety factors built in for unmetered usage)

Parameter	USEPA MCL	Influent Average	Standard No. 42: Aesthetic Effects			% Reduction		Min. Required Reduction
			Influent Challenge Concentration	Average	Maximum	Average	Minimum	
Chlorine	—	1.845 mg/L	2.0 mg/L \pm 10%	< 0.05 mg/L	0.05 mg/L	> 97.29%	96.43%	\geq 50%
T & O	—	—	—	—	—	—	—	—
Particulate**	—	143,333 #/mL	at least 10,000 particles/mL	29.83 #/mL	140 #/mL	99.98%	99.91%	\geq 85%

Parameter	USEPA MCL	Influent Average	Standard No. 53: Health Effects			% Reduction		Min. Required Reduction
			Influent Challenge Concentration	Average	Maximum	Average	Minimum	
Turbidity	1 NTU***	10.3 NTU***	1 \pm 1 NTU***	0.106 NTU	0.14 NTU	98.97%	98.61%	0.5 NTU
Cysts	99.95% Reduction	200,000 #/L	Minimum 50,000 L	0	0	> 99.99%	> 99.99%	> 99.95%
Lead at pH 6.5	0.015 mg/L	0.15 mg/L	0.15 mg/L \pm 10%	< 0.001 mg/L	< 0.001 mg/L	> 99.33%	> 99.33%	0.010 mg/L
Lead at pH 8.5	0.015 mg/L	0.14 mg/L	0.15 mg/L \pm 10%	0.001 mg/L	0.003 mg/L	> 99.29%	97.86%	0.010 mg/L
Lindane	0.0002 mg/L	0.0216 mg/L	0.002 mg/L \pm 10%	< 0.00002 mg/L	< 0.00002 mg/L	99.07%	98.75%	0.0002 mg/L
Atrazine	0.003 mg/L	0.008 mg/L	0.009 mg/L \pm 10%	< 0.002 mg/L	< 0.002 mg/L	> 76.12%	> 66.67%	0.003 mg/L

* Tested using a flow rate of 0.5 gpm; pressure of 60 psig; pH of 7.5 \pm 0.5; temp. of 68° \pm 5°F (20° \pm 3°C)

** Measurement in Particles/ml. Particles used were 0.5-1 microns

*** NTU=Nephelometric Turbidity units

Operating Specifications

- Capacity: certified for up to 750 gallons (2,838 l); up to six months
- Pressure requirement: 40–120 psi (2.8–8.2 bar)
- Temperature: 33–100°F (0.6–38°C)
- Flow rate: 0.5 gpm (1.9 lpm)

General Installation/Operation/Maintenance Requirements

- Flush new cartridge at full flow for 3 minutes to purge out trapped air.
- Replace cartridge when flow becomes too slow.

Special Notices

- Installation instructions, parts and service availability, and standard warranty are included with the product when shipped.
- This drinking water system must be maintained according to manufacturer’s instructions, including replacement of filter cartridges.
- Do not use with water that is microbiologically unsafe or of unknown quality without adequate disinfection before or after the system. Systems certified for cyst reduction may be used on disinfected water that may contain filterable cysts.
- The contaminants or other substances removed or reduced by this water treatment system are not necessarily in your water.
- Check for compliance with the state and local laws and regulations.
- Note that while the testing was performed under standard laboratory conditions, actual performance may vary. Systems must be installed and operated in accordance with manufacturer’s recommended procedures and guidelines.

System tested and certified by NSF International against Standard 42 for the reduction of chlorine, taste and odor, particulate Class I and Standard 53 for the reduction of cyst, lead, Lindane, Atrazine and turbidity.



Manufactured for: General Electric Company, Louisville, KY 40225

State of California
Department of Health Services
Water Treatment Device
Certificate Number

03 - 1559

Date Issued: April 28, 2003

Trademark/Model Designation

GE GSWF

Replacement Elements

GSWF

Manufacturer: General Electric Consumer Products

The water treatment device(s) listed on this certificate have met the testing requirements pursuant to Section 116830 of the Health and Safety Code for the following health related contaminants:

Microbiological Contaminants and Turbidity

Cysts
Turbidity

Inorganic/Radiological Contaminants

Asbestos
Lead

Organic Contaminants

Atrazine
Lindane
2,4-D

Rated Service Capacity: 750 gal

Rated Service Flow: 0.5 gpm

Conditions of Certification:

Do not use where water is microbiologically unsafe or with water of unknown quality, except that systems certified for cyst reduction may be used on disinfected waters that may contain filterable cysts.

Notes

30" Bottom-Freezer

Notes

30" Bottom-Freezer

With the purchase of your new Monogram appliance, receive the assurance that if you ever need information or assistance from GE, we'll be there. All you have to do is call!

**GE Answer
Center®
800.626.2000**

Whatever your question about any Monogram major appliance, GE Answer Center® information service is available to help. Your call—and your question—will be answered promptly and courteously. Call the GE Answer Center® Monday to Friday, 8 a.m. to 10 p.m. EST, and Saturday, 8 a.m. to 7 p.m.

OR

Visit our Website at: monogram.com

**In-Home Repair
Service
800.444.1845**

A GE consumer service professional will provide expert repair service, scheduled at a time that's convenient for you. To schedule service, call Monday to Friday, 7 a.m. to 10 p.m. EST, or Saturday and Sunday, 8 a.m. to 6 p.m. Many GE Consumer Service company-operated locations offer you service today or tomorrow, or at your convenience. Our factory-trained technicians know your appliance inside and out—so most repairs can be handled in just one visit.

**For Customers
With Special
Needs...
800.626.2000**

GE offers Braille controls for a variety of GE appliances, and a brochure to assist in planning a barrier-free kitchen for persons with limited mobility.

Consumers with impaired hearing or speech who have access to a TDD or a conventional teletypewriter may call 800.TDD.GEAC (800.833.4322) to request information or service.

**Service
Contracts
800.626.2224**

You can have the secure feeling that GE Consumer Service will still be there after your warranty expires. Purchase a GE contract while your warranty is still in effect and you'll receive a substantial discount. With a multiple-year contract, you're assured of future service at today's prices.

**Parts and
Accessories
800.626.2002**

Individuals qualified to service their own appliances can have parts or accessories sent directly to their home. The GE parts system provides access to over 47,000 parts...and all GE Genuine Renewal Parts are fully warranted. VISA, MasterCard and Discover cards are accepted. Visit www.GEAppliances.com.

User maintenance instructions contained in this manual cover procedures intended to be performed by any user. Other servicing generally should be referred to qualified service personnel. Caution must be exercised, since improper servicing may cause unsafe operation.

YOUR MONOGRAM REFRIGERATOR AND FREEZER WARRANTY
Staple sales slip or cancelled check here. Proof of original purchase date is needed to obtain service under warranty.

WHAT IS COVERED

From the Date of the Original Purchase

LIMITED TWO-YEAR WARRANTY

For two years from date of original purchase, we will provide, free of charge, parts and service labor in your home to repair or replace *any part of the refrigerator or freezer* that fails because of a manufacturing defect.

LIMITED FIVE-YEAR WARRANTY

For five years from date of original purchase, we will provide, free of charge, parts and service labor in your home to repair or replace *any part of the sealed refrigerating system* (the compressor, condenser, evaporator and all connecting tubing) that fails because of a manufacturing defect.

LIMITED ADDITIONAL SIXTH- THROUGH TWELFTH-YEAR WARRANTY ON THE SEALED SYSTEM

For the sixth through twelfth year from the date of the original purchase, we will provide, free of charge, replacement parts for *any part of the sealed refrigerating system* (the compressor, condenser, evaporator and all connecting tubing) that fails because of a manufacturing defect. You pay for the service trip to your home and for service labor charges.

LIMITED THIRTY-DAY WARRANTY ON WATER FILTER CARTRIDGE (Water filter, if included)

From the date of the original purchase we will provide, free of charge, replacement parts for *any part of the water filter cartridge* that fails because of a manufacturing defect. During this limited thirty-day warranty, we will also provide, free of charge, a replacement water filter cartridge.

.....
This warranty is extended to the original purchaser and any succeeding owner for products purchased for ordinary home use in the 48 mainland states, Hawaii, Washington, D.C. or Canada. If the product is located in an area where service by a GE Authorized Servicer is not available, you may be responsible for a trip charge or you may be required to bring the product to an Authorized GE Service location for service. In Alaska the warranty is the same except that it is LIMITED because you must pay to ship the product to the service shop or for the service technician's travel costs to your home.

All warranty service will be provided by our Factory Service Centers or by our authorized Customer Care® servicers during normal working hours.

Should your appliance need service, during warranty period or beyond, call 800.444.1845. Please have your serial number and model number available when calling for service.

WHAT IS NOT COVERED

- Service trips to your home to teach you how to use the product.
- Replacement of house fuses or resetting of circuit breakers.
- Damage to the product caused by accident, fire, floods or acts of God.
- Failure of the product if it is used for other than its intended purpose or used commercially.
- Damage caused after delivery.
- Improper installation, delivery or maintenance. If you have an installation problem, contact your dealer or installer. You are responsible for providing adequate electrical, plumbing and other connecting facilities.
- Replacement of the light bulbs, if included, or water filter cartridge, if included, other than as noted above.
- Replacement of the water filter cartridge, if included, due to water pressure that is outside the specified operating range or due to excessive sediment in the water supply.
- Loss of food due to spoilage.
- Incidental or consequential damage caused by possible defects with this appliance.
- Product not accessible to provide required service.

EXCLUSION OF IMPLIED WARRANTIES—Your sole and exclusive remedy is product repair as provided in this Limited Warranty. Any implied warranties, including the implied warranties of merchantability or fitness for a particular purpose, are limited to one year or the shortest period allowed by law.

Some states do not allow the exclusion or limitation of incidental or consequential damages, so the above limitation or exclusion may not apply to you. This warranty gives you specific legal rights, and you may also have other rights which vary from state to state. To know what your legal rights are in your state, consult your local or state consumer affairs office or your state's Attorney General.

**Warrantor: General Electric Company,
Louisville, KY 40225**



GE Consumer & Industrial Appliances
General Electric Company
Louisville, KY 40225
GEAppliances.com

197D8243P001
49-60615

08-10 GE