



# Freestanding Ranges

FGEF301DN F/W/B

30" Electric



## Product Dimensions

Height (Max.)	49"
Width	30"
Depth (Including Handle)	28-1/4"

## More Easy-To-Use Features

**One-Touch Keep Warm Setting**  
Just one touch of a button keeps food warm until everything – and everyone – is ready.

**Smudge-Proof Stainless Steel<sup>1</sup>**  
Real Stainless Steel with a protective coating reduces fingerprints and smudges so it's easy to clean.

**Even Baking Technology**  
Our latest technology ensures even baking every time.

**One-Touch Self Clean**  
Start the self-cleaning cycle with just the touch of a button.

**Quick Clean**  
For a quick, light oven cleaning.

**Delay Start**  
Set your oven to begin cooking on your schedule. It can be programmed from one to 24 hours.

Sabbath Mode (Star-K® Certified)

## Available in:



## Signature Features

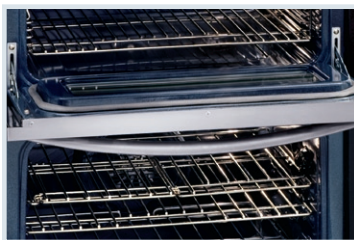

### Fits-More™ Double Oven Range

A second 2.3 cu. ft. oven gives you more space to cook multiple dishes at the same time.



### Quick Boil

Boils water faster.

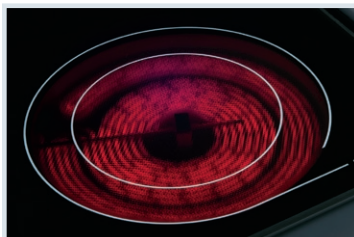

### SpaceWise® Expandable Element

Flexible element expands to your cooking needs.



### Express-Select® Controls

Easily go from warm to boil.

Elements	Size	Watts
Right Front	6" / 9" Expandable	1,600 / 3,000
Right Rear	6"	1,200
Left Front	9"	2,500
Left Rear	6"	1,200

<sup>1</sup>Select model only

Features	
Oven Control/Timing System	Express-Select® Controls
Surface Type	Black Ceramic Glass
Window	Large
Exterior Door Finish	Smudge-Proof Stainless Steel (F), Color-Coord. (W/B)
Handle Design	Stainless Steel (F), Color-Coordinated (W/B)
Exterior Finish (Side Panels)	Black (F), Color-Coord, (W/B)
Convection System	
Oven Cleaning System	Self Clean
Upper Oven	Fits-More™ Upper Oven
Oven Controls	
Bake/Broil	Yes/Variable (400-550°F)
Effortless™ Convection Conversion	
Convection Bake/Broil/Roast	
Quick Bake Convection	
Quick Preheat	
Effortless™ Temperature Probe	
My Favorite	
Chicken Nugget Button	
Pizza Button	
Keep Warm	Yes
Add-a-Minute	Yes
Delay Start	Yes
Self Clean	Yes
Quick Clean Option	Yes
Delay Clean	2, 3, 4 Hours
Kitchen Timer / Timed Cook Option	Yes/Yes
Auto Oven Shutoff	6 Hours
Oven Lock-Out	Yes
Cooktop Features	
Right Front Element (Watts)	SpaceWise® Expandable 6"/9"- 1,600/3,000
Right Rear Element (Watts)	6" - 1,200
Left Front Element (Watts)	9" - 2,500
Left Rear Element (Watts)	6" - 1,200
Bridge Element (Watts)	
Center Element (Watts)	
Oven Features	
Upper/Lower Oven Capacity (Cu.Ft.)	2.3/4.4
Upper/Lower Oven Light	1/1
Hidden Bake Element	
Upper/Lower Rack Configuration	1/2 Standard
Baking System	Even Baking Technology
Broiling System	Vari-Broil™
Upper Bake/Broil Burners (Watts)	2,200/3,000
Lower Bake/Broil Burners (Watts)	3,000/3,400
Certifications	
Sabbath Mode (Star-K® Cert.)	Yes
Specifications	
Upper Oven Interior (H x W x D)	8-3/8" x 24-3/8" x 19-3/8"
Lower Oven Interior (H x W x D)	16-1/2" x 24-1/8" x 18-7/8"
Power Supply Connection Location	Left Bottom Rear
Voltage Rating	240V/208V/60Hz
Connected Load (kW Rating) @ 240/208 Volts	14.5/10.9
Minimum Circuit Required (Amps)	40A
Shipping Weight (Approx.)	255 Lbs

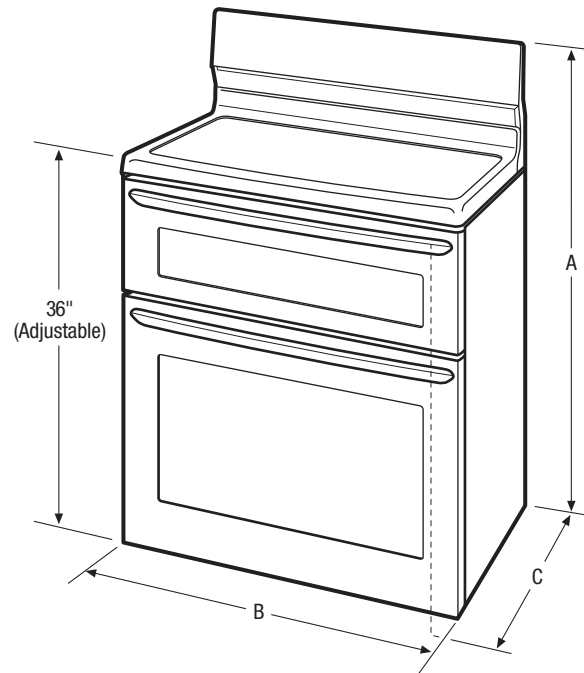

*NOTE: For planning purposes only. Always consult local and national electric codes. Refer to Product Installation Guide for detailed installation instructions on the web at [frigidaire.com](http://frigidaire.com).*



Product Dimensions	
A - Height (Max.)	49"
B - Width	30"
C - Depth (Including Handle)	28-1/4"
Depth with Door Open 90°	46"

Cutout Dimensions	
Height (Stand.)	36"
Width (Min.)	30-1/8"
Depth (Min.)	24"

Accessories information available on the web at [frigidaire.com](http://frigidaire.com)

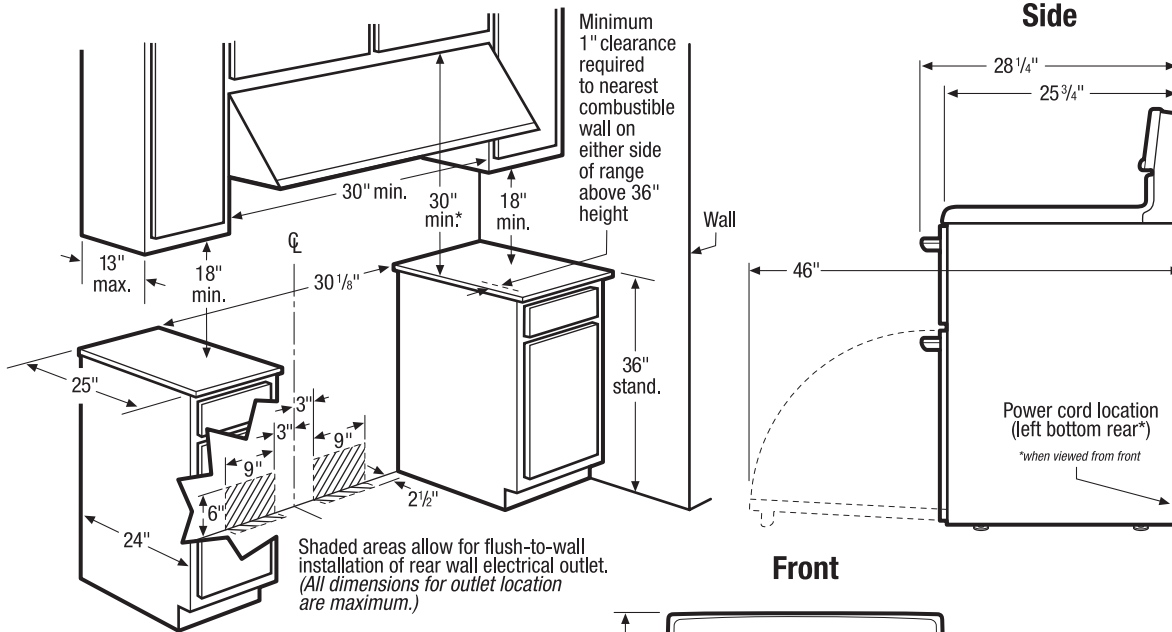

**\*Note:** 30" minimum clearance between top of cooking surface and bottom of unprotected wood or metal overhead cabinet; or 24" minimum clearance when bottom of wood or metal overhead cabinet is protected by not less than 1/4" flame-retardant millboard covered with not less than No. 28 MSG sheet steel, 0.015" stainless steel, 0.024" aluminum or 0.020" copper. 0" clearance is minimum for rear of range. Follow all dimension requirements provided above to prevent property damage, potential fire hazard, and incorrect countertop and cabinet cuts.

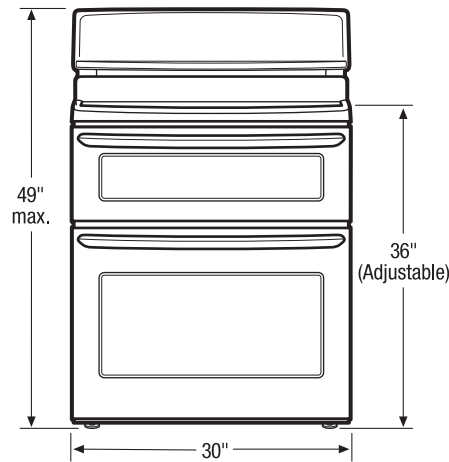

**Freestanding Range Specifications**

- Product Shipping Weight (approx.) - 255 Lbs.
- Single phase 3- or 4-wire cable, 120/240 or 120/208 Volt, 60 Hertz, fused on both sides of line with ground.
- Connected Load (kW Rating) @ 240/208 Volts = 14.5/10.9
- Recommended Circuit Breaker - 40 Amps
- Always consult local and national electric codes.
- Floor beneath range MUST be solid and level.
- Overhead cabinetry should not exceed a 13" maximum depth.
- Absolute minimum horizontal distance between overhead cabinets installed to either side of appliance must be no less than maximum width of appliance.
- Range can be installed flush to wall with 0" minimum rear clearance.
- Minimum 1" clearance required from edge of rangetop to nearest combustible wall on either side of range above 36" height.

- Allow 30" minimum clearance between top of cooking surface and bottom of unprotected wood or metal overhead cabinet; or 24" minimum clearance when bottom of wood or metal overhead cabinet is protected by not less than 1/4" flame retardant millboard covered with not less than No. 28 MSG sheet steel, 0.015" stainless steel, 0.024" aluminum or 0.020" copper.
- To reduce risk of fire when using overhead cabinetry, install range hood that projects horizontally a recommended minimum of 5" beyond bottom of cabinets.
- Follow all dimension requirements provided to prevent property damage, potential fire hazard, and incorrect countertop and cabinet cuts.

**Note:** For planning purposes only. Refer to Product Installation Guide on the web at [frigidaire.com](http://frigidaire.com) for detailed instructions.



Use these dimensions and clearance instructions for planning purposes only. For detailed installation instructions, refer to installation guide, packed with product, or on the web at frigidaire.com.

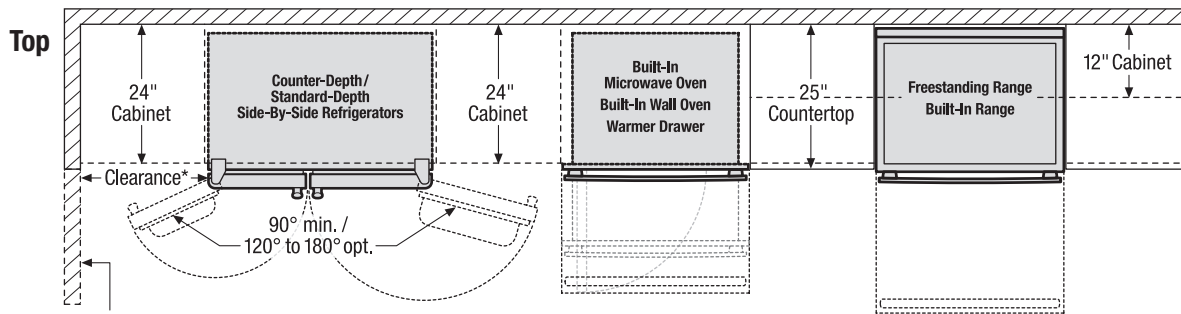
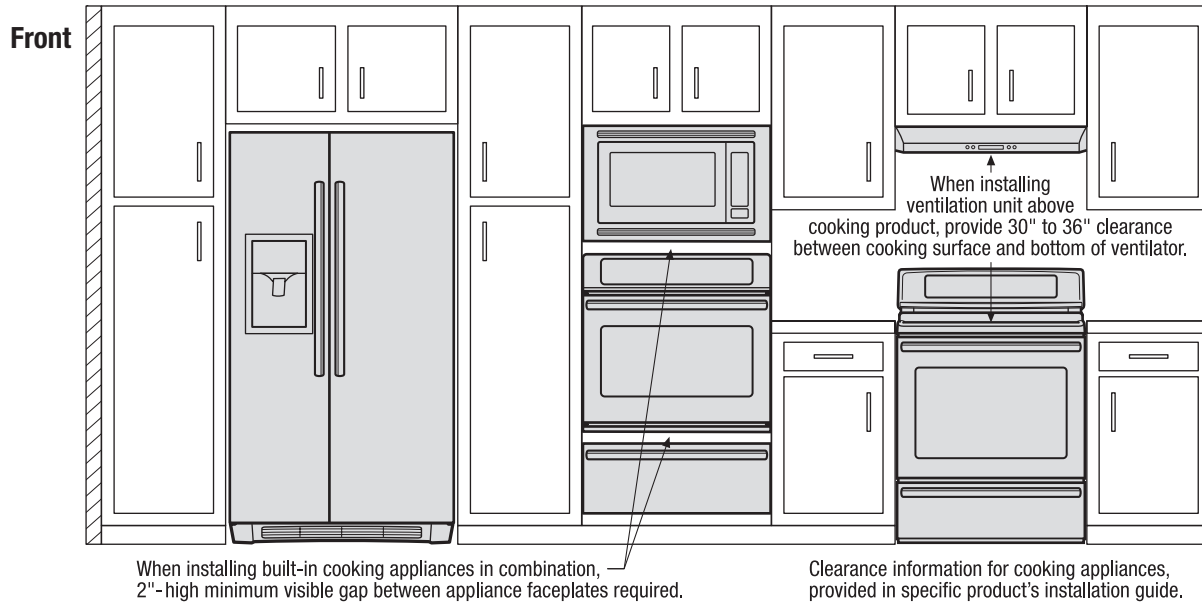

\*When installing side-by-side refrigerator adjacent to wall, cabinet or another appliance that extends beyond front edge of unit, 20" minimum clearance recommended to allow for optimum 120° to 180° door swing, providing complete drawer/crisper access and removal. (Absolute 4-1/2" minimum clearance will ONLY allow for 90° door swing which will provide limited drawer/crisper access with restricted removal.)

When installing appliance with sliding drawer, swinging or drop-down door directly across from obstructions, provide sufficient clearance for drawer extension or door swings.

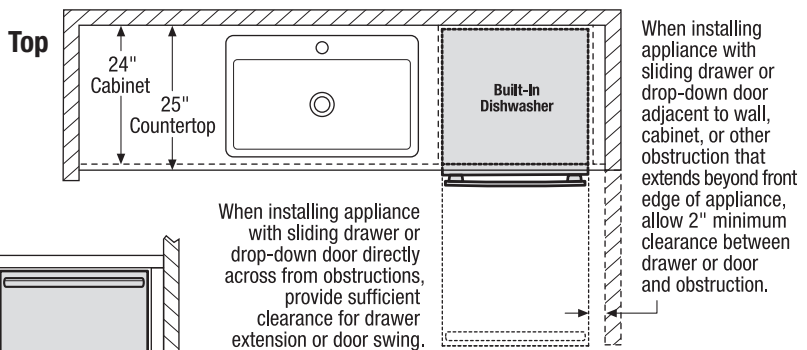

Use these dimensions and clearance instructions for planning purposes only. For detailed installation instructions, refer to installation guide, packed with product, or on the web at frigidaire.com.

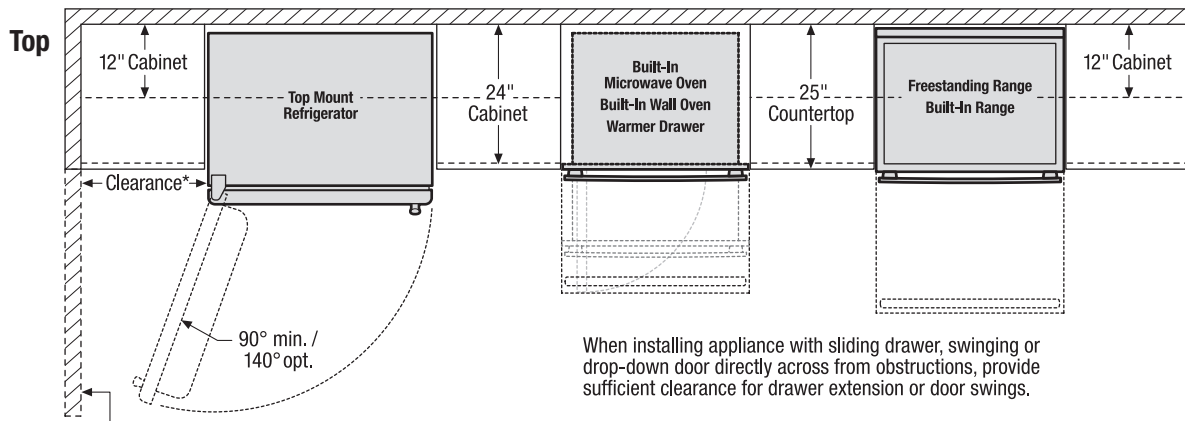
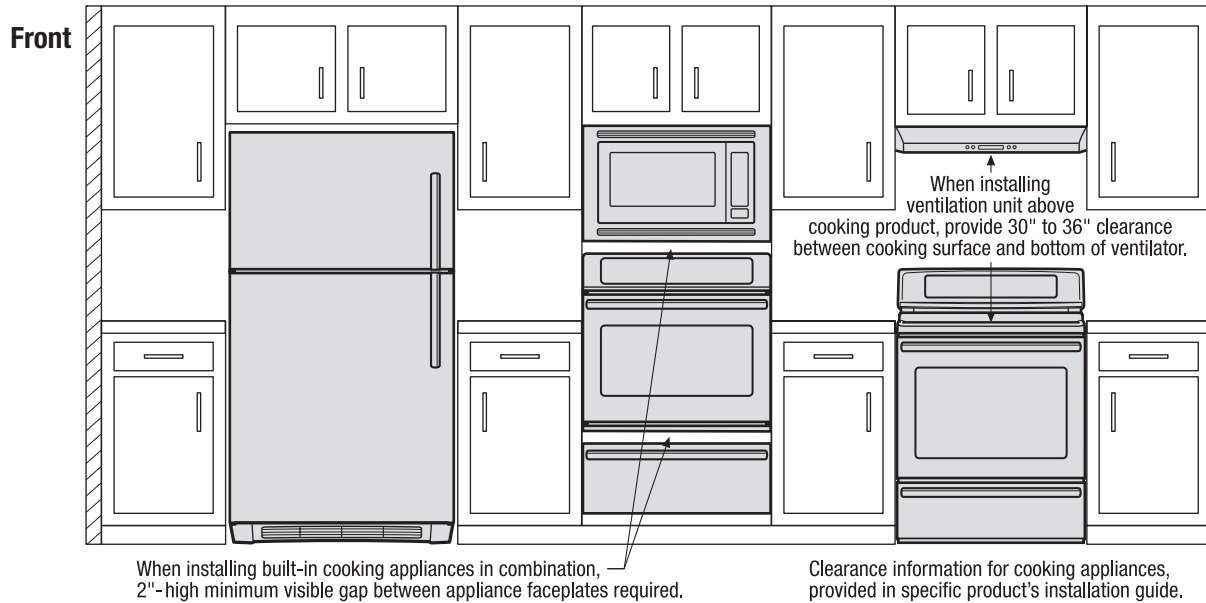

\*When installing top mount refrigerator adjacent to wall, cabinet or other appliance that extends beyond front edge of unit, 20" minimum clearance recommended to allow for optimum 140° door swing, providing complete crisper access and removal. (Absolute 3" minimum clearance will ONLY allow for 90° door swing which will provide limited crisper access with restricted removal.)

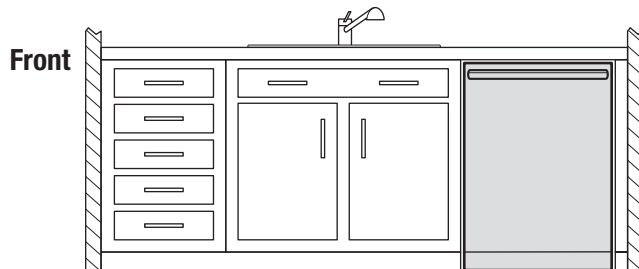
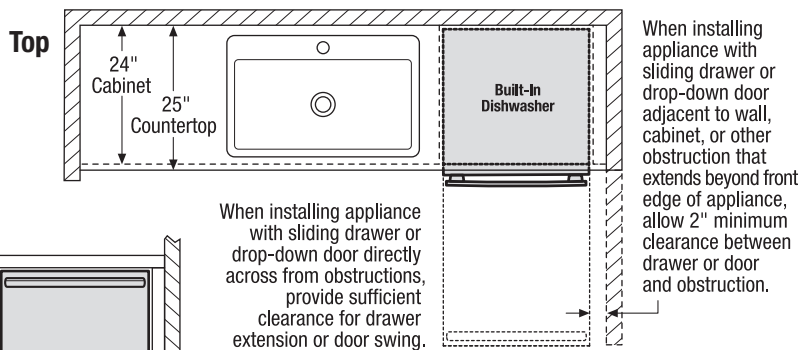

Use these dimensions and clearance instructions for planning purposes only. For detailed installation instructions, refer to installation guide, packed with product, or on the web at frigidaire.com.

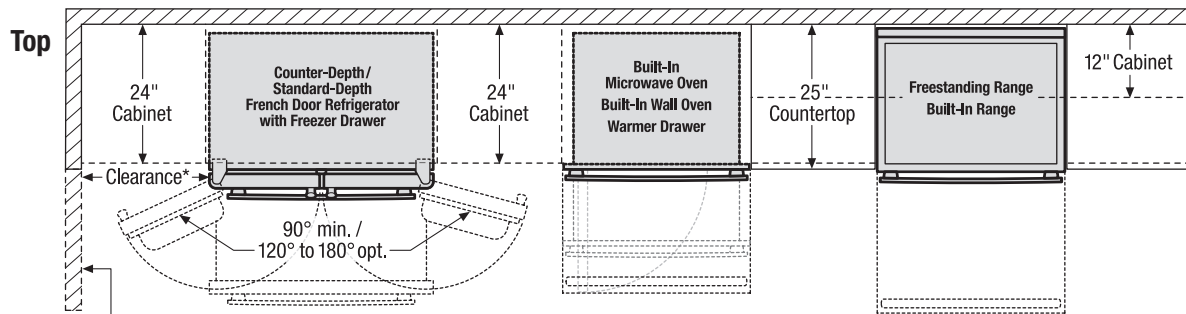
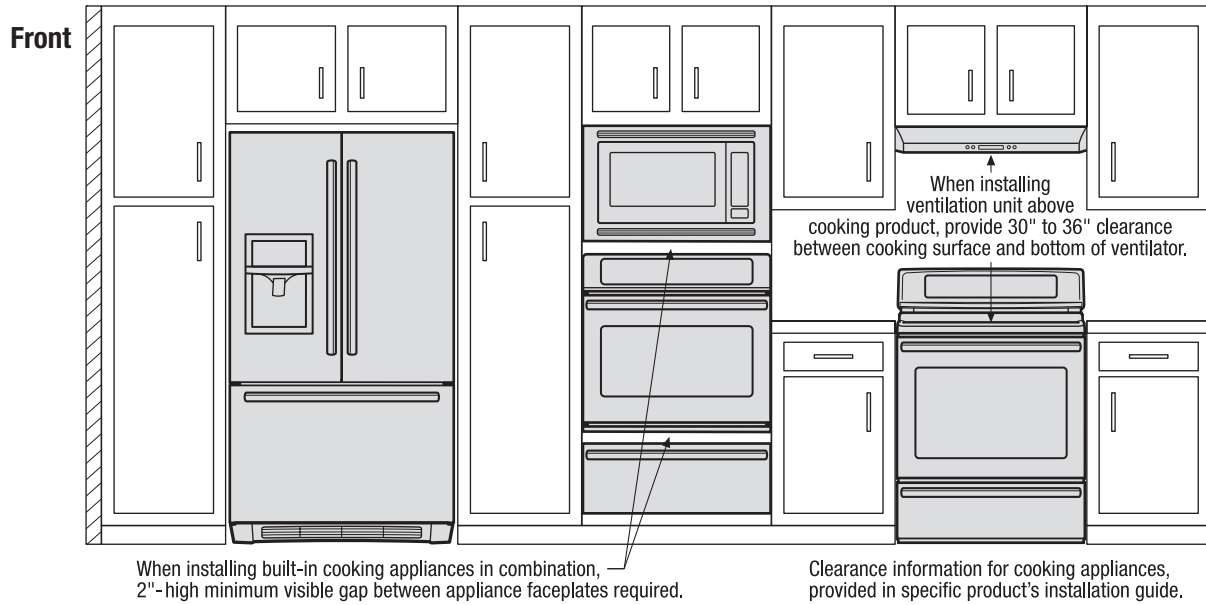

\*When installing French door refrigerator adjacent to wall, cabinet or another appliance that extends beyond front edge of unit, 20" minimum clearance recommended to allow for optimum 120° to 180° door swing, providing complete drawer/crisper access and removal. (Absolute 4-1/2" minimum clearance will ONLY allow for 90° door swing which will provide limited drawer/crisper access with restricted removal.)

When installing appliance with sliding drawer, swinging or drop-down door directly across from obstructions, provide sufficient clearance for drawer extension or door swings.

