

Como



WALL-MOUNT CHIMNEY HOOD

Como combines arched glass wings and stainless steel to create a light and airy environment...the perfect centerpiece for any contemporary kitchen. This gently flowing design is powered by a 600 CFM blower that can handle the demands generated by today's cooktops. The high-tech LCD panel controls multiple functions, including halogen lighting with 2 light intensities and a sensor that tells you when to clean your dishwasher-safe anodized aluminum mesh filters. Designed for standard ducted installation, Como can also be installed as a recirculating system using the Recirculating Kit, available as an accessory.

FEATURES

• **Advanced Electronic Touch Controls**

State-of-the-art electronics deliver maximum user convenience and control. LCD function display with elegant blue illumination combined with low-profile, easy-to-clean touchpads is your interface with a multi-function control system, including...

- On/Off control
- Programmable timer and buzzer
- Four blower speeds
- Clock
- **HeatGuard™** automatically adjusts blower speed if heat exceeds 158°F for safety and convenience
- Two light intensities
- Filter Saturation Monitor detects excessive levels within both grease and charcoal filters



• **600 CFM 4-Speed Internal Blower**

• **2 Halogen Lamps** with two light intensities (12V 20W bulbs included)

• **Dishwasher-Safe Anodized Aluminum Mesh Filter**

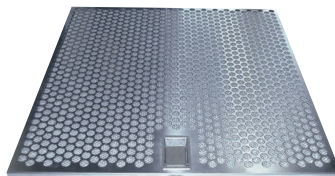

Stainless Steel Mesh Filter

Available as an optional upgrade
(see back for accessory details)

- **Telescopic Chimney Extension** – For ceiling heights 7' 5" to 10'
- **8" Round Duct Transition**
- **One-Way No Return Valve** eliminates outside air drafts.

elica

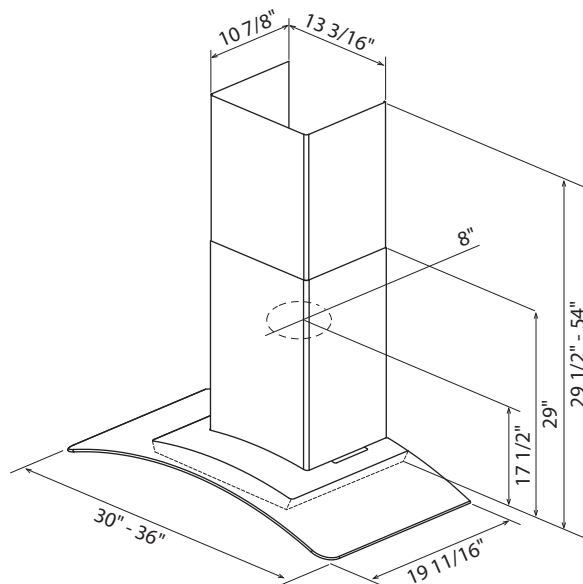

MODEL NUMBER	FINISH	DIMENSIONS		SHIPPING WEIGHT
		WIDTH	DEPTH	
ECM630SS	Stainless Steel & Glass	30"	19-11/16"	62 lbs
ECM636SS	Stainless Steel & Glass	36"	19-11/16"	68 lbs

HOOD MOUNTING HEIGHT ABOVE COOKING SURFACE

GAS		ELECTRIC	
minimum	maximum	minimum	maximum
30"	34"	24"	30"

CHIMNEY HEIGHT *(based on recommended mounting heights listed above)*

DUCTED		RECIRCULATING	
Gas min./max.	Electric min./max.	Gas min./max.	Electric min./max.
7' 11" - 10'	7' 5" - 9' 8"	8' 3" - 10' 4"	7' 9" - 10'

BLOWER PERFORMANCE

SPEED LEVEL	AIRFLOW IN CFM (CUBIC FEET PER MINUTE)	SOUND LEVEL (IN SONES)
1	160	1.6
2	280	3.5
3	470	6.5
4	600	8.7

COMO ACCESSORIES

MODEL NUMBER	DESCRIPTION	SHIPPING WEIGHT
EXXRCK05	Recirculating Kit	6.6 lbs
EXXRCK02	CFM Reduction Kit	5.5 lbs
EXXGFKSS	Stainless Steel Mesh Filter	5.5 lbs

  **ELECTRICAL:**
AC Input: 120V - 60Hz, AC Power Max.: 490W at 4.1 Amps