

## SCR1155W

58.38" x 23.63" x 22.88" (H x W x D)

Commercial beverage merchandiser with 11 cu.ft. capacity, self-closing door, and a digital thermostat; replaces SCR1155

### Highlights:

Commercially listed to NSF-7 standards for use in foodservice establishments

Full display all the way down to the floor

Self-closing door is ideal for busy commercial settings

Easy temperature management with a digital thermostat



Commercially listed	ETL-S listed to NSF standards for commercial use
Factory installed lock	Keyed lock for secure interior
Double pane tempered glass door	Heat-safe glass door offers full display all the way down to the floor
Recessed LED lighting	Energy efficient lighting offers full view of interior
Self-closing door	Door will automatically close when left ajar, preventing items from accidentally being exposed to ambient temperatures
Digital thermostat	Electronic controls for precise temperature management with a readout in Celsius or Fahrenheit; temperature range: 34-43 °F
Professional handle	Solid chrome handle with brushed stainless steel look
Adjustable wire shelves	Rearrange refrigerator space to accommodate all sizes or remove shelves for simple cleanup
Frost-free operation	No-frost system simplifies maintenance
100% CFC Free	Environmentally friendly design with no ozone-damaging chemicals

## Specifications:

Height	58.38"
Width	23.63"
Depth	22.88"
Capacity	11.0 cu.ft.
Ext Depth with Handle	24.0"
Interior Height 1	49.0"
Interior Width 1	20.0"
Interior Depth 1	17.5"
Shipping Weight	160.0 lbs.
Weight	153.0 lbs.
Amps	2.8
US Electrical Safety	ETL
Canadian Electrical Safety	ETL-C
Voltage/Frequency	115 V AC/60 Hz
Reversible	No
Door Swing	RHD
Shelf Quantity	4
Adjustable Shelf	true
Shelf Type	Wire
Defrost Type	Frost-Free
Depth with door at 90°	45.0"
Thermostat Type	Digital
Fan Type	Interior
Light	true
Freon Oz	3.88
High Side PSI	270.0
Low Side PSI	105.0
Freon Type	R134a
Level Legs Quantity	4
Parts/Labor Warranty	1 Year
Compressor Warranty	5 Years
Sanitation	ETL-S

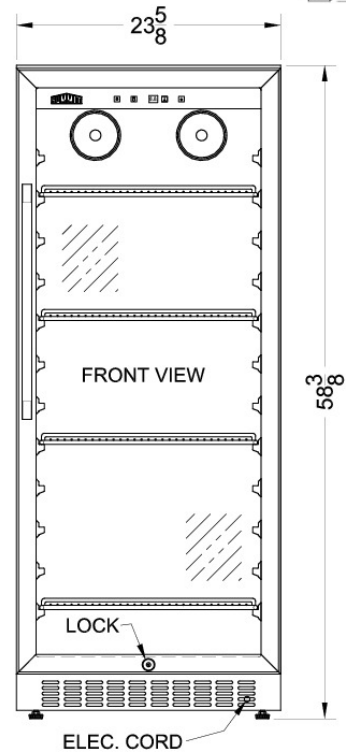
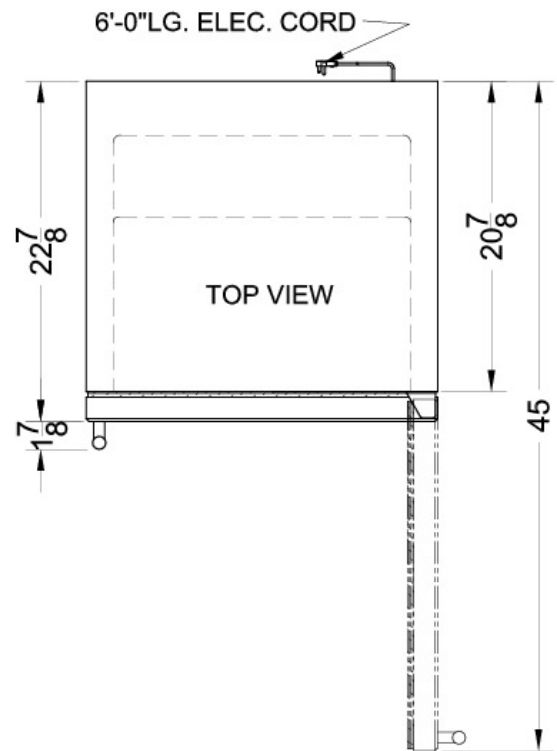

Summit Appliance Division, Felix Storch, Inc.  
 770 Garrison Ave • Bronx, NY 10474  
 Phone: 718-893-3900 • Fax: 718-842-3093  
 Email: [info@summitappliance.com](mailto:info@summitappliance.com)