

Instructions for use

ice-cream freezers

Please see rating plate at the rear side of the cabinet.

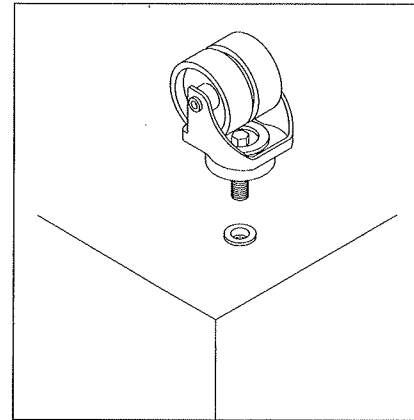
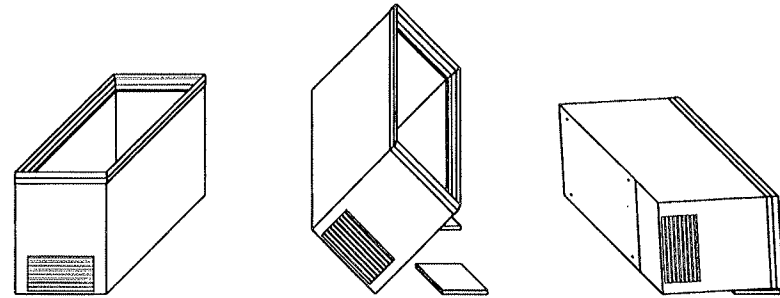

Field of application

The freezer is designed to store frozen foods.

Placing

The freezer must be placed on a firm and flat surface. To ensure a correct functioning a good air circulation around the freezer is imperative. Between the air intake and the wall (at the compressor end) there should be at least 10 cm/4 in and on the other sides at least 3 cm/1.5 in.

The appliance should stand in as cool as possible and not be exposed to radiant heat from the sun or other source of heat.

Mains connection

The freezer should be connected to a grounded wall socket, which should be fused according to national requirements. Please see rating plate at the rear side of the cabinet. Permissible voltage variations +/- 10%. Larger variations may affect the operation of the

freezer and the manufacturer does not give guarantee for any consequent damages.

Near the freezer there should be an accessible switch. No other current-consuming devices should be connected to the same socket as the freezer.

Many electric installations are equipped with an GFI-relay. This relay cuts off the current in case of a leakage and thus gives security against most accidents caused by electricity.

In regions where the electricity supply takes place through overhead wires the lightning during a storm may affect the installation in such a way that the GFI-relay cuts off the current. This circumstance should be considered when the appliance is placed in areas where a power cut would not be noticed immediately. This possibility should be considered when installing the product.

Note: Some models are equipped with a detachable locking device. If the lock is not used it should be kept out of reach of children.

Locking device

Push the lids against the ends so that the hole at the end of the lid catches the pin mounted on the frame. The locking device (key + lock) is inserted in the keyhole, turned to the right and locked.

Operation and temperature control

The thermostat is placed on the right side of the freezer at the air intake of the compressor (the gill grate).

The thermostat knob which is turned with a coin has continuously variable setting. The warmest

position is obtained by turning the knob counter-clockwise whereas turning clockwise gives the lowest temperature.

The temperature in the freezer depends on the ambient temperature, the quantity of goods, the temperature of the goods when placed in the freezer, how often the lid is opened, etc. If the freezer is full the thermostat is set on a lower temperature in order to ensure that the storage temperature is sufficiently low also in the upper packages.

Lamps (some models only)

The alarm lamp (red) lights up if the inside temperature of the chest freezer becomes too high, i.e. there is a risk that the frozen foods will thaw. In the following situations the lamp may light up without there being any risk as to the frozen foods:

- when starting up the appliance,
- when placing major quantities of fresh foods in the appliance and
- if the lid has been opened for some time.

The mains-on lamp (green) will stay lit as long as the appliance is connected to the mains outlet and as long as the automatic adjustment of temperature functions. If the mains plug is removed or if the power supply fails due to other reasons the lamp will switch off.

Starting

The freezer is plugged in and the thermostat is set so that the temperature is always below -18°C . Let the freezer run for a few hours before the frozen foods are placed in the freezer.

Packing and placing

The packing of the goods must be air- and moisture-proof to avoid drying. The freezer should only be filled up to 30 mm (12 in) from the edge of the inner tank.

Do not put bottles in the freezer to cool as the liquid may burst the bottles when freezing.

Storage times

Notice that the storage times vary with the different foods. See the handbooks to the storage of foods.

In case of prepacked frozen foods the manufacturer's instructions should always be followed.

General advice

If the freezer will not start the following points should be checked before you call in a service engineer:

- that the plug is plugged in properly.
- that the fuse has not blown or breaker tripped.
- that the power supply has not been interrupted.

If the compressor makes repeated attempts to start but still does not start running, turn off the freezer and let the compressor rest for 15 to 20 minutes before another attempt to start is made.

It is quite normal that sometimes the freezer feels warm on the outside. This is due to the fact that the heat developed during the freezing process is emitted from the outer casing. At the same time this heat prevents condensation of moisture which could otherwise result in rusting.

Defrosting

Frost on the inner sides of the freezer cannot be avoided. The formation of frost is the result of the moisture of the air moving towards the cold surfaces of the freezer.

Note! Non-tight-fitting packing also gives off moisture which contributes to the formation of frost. The lid should not be opened unnecessarily and never be left open for long. A thin coat of frost or ice does not disturb the functioning of the freezer. When the coat of frost or ice is approx. 5 mm (0.2 in) thick the freezer should be defrosted.

The current is switched off. The goods are removed, packed in newspapers, blankets, or simili and placed in a cool place.

Loose frost may carefully be removed with a plastic scraper. Never use a knife or other sharp tool which may damage the freezer or the refrigerating system. The defrosting may be hastened by placing one or more bowls with hot water in the freezer. After some time the lid is opened and the loosened coat of ice is carefully removed. Never hasten the defrosting with other source of heat than hot water as you may otherwise damage the material of the freezer or even cause a fire.

The defrosting should always be combined with a cleaning of the freezer.

Cleaning

The freezer should be cleaned carefully from time to time. The current must be switched off and the plug is pulled out. The freezer should be washed on the inside and on the outside with lukewarm water with an unscented detergent added. Grease and the like should be carefully washed off. Leave the freezer open for some time and let it dry thoroughly. Close the lid and reconnect the appliance to the supply. After approx. 20 minutes the goods may be put back in the freezer.

If the freezer does not operate satisfactorily

Check the following before you call in a service engineer:

- that the appliance is plugged in properly and that the current is switched on.
- that the fuse has not blown or breaker tripped.
- that there is no power cut.
- that the thermostat setting is correct.
- that the lids are closed properly.
- that the freezer is not placed too close to a source of heat.
- that the interior coat of ice or frost is not too thick.

If the compressor makes repeated attempts to start but in vain, turn off the freezer for approx. 20 minutes and try again. Do not perform other operations. The wrong procedure may result in personal injuries or cause further functional problems.

Equipment

Some models are equipped with lock and/or wire baskets. A wire basket keeps the frozen foods in order and facilitates positioning.

Additional equipment

Lock and wire baskets can be obtained from the dealer as additional equipment.

Rights to alterations reserved.

Installation instruction, Flat & Curved

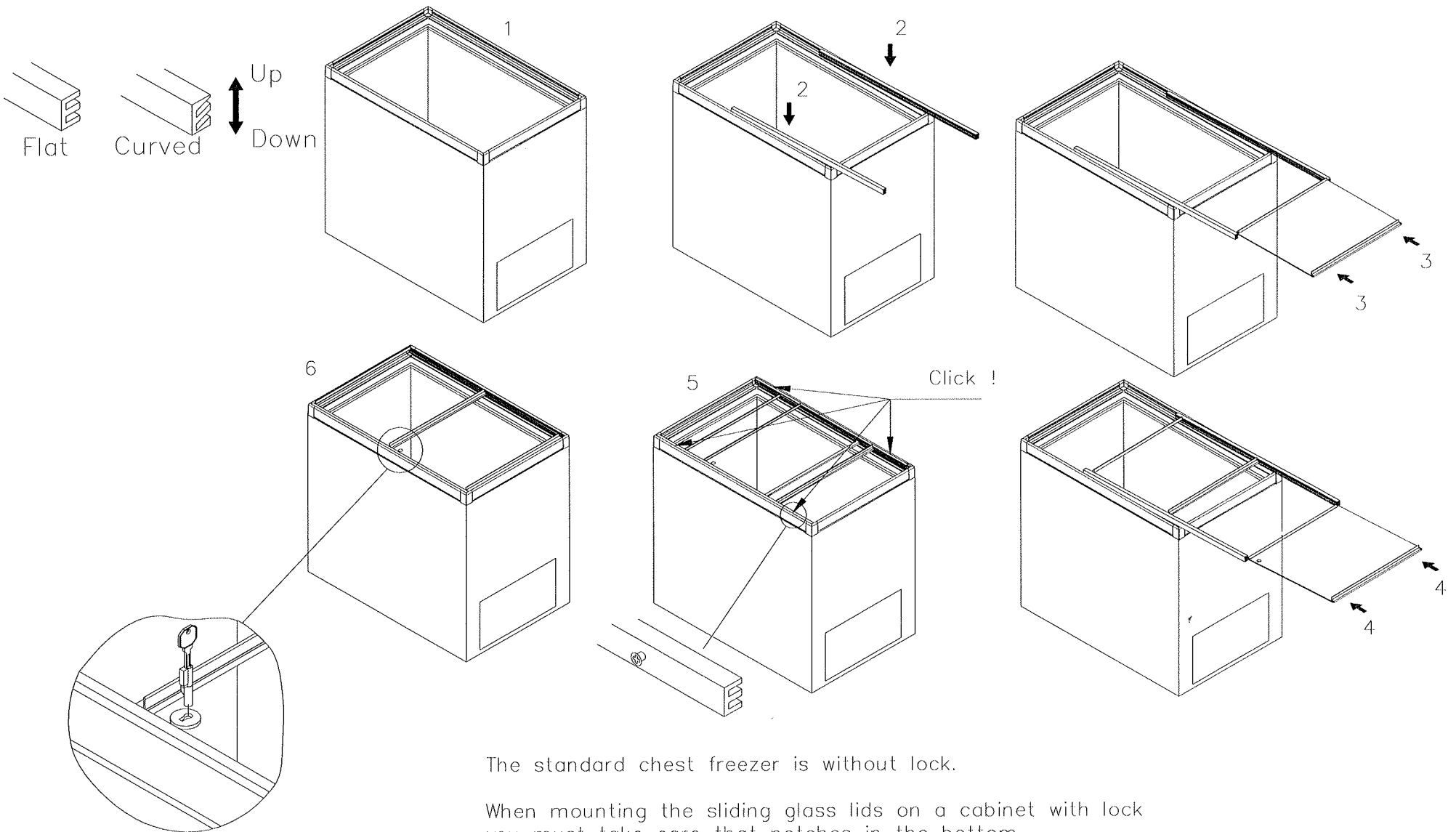

The standard chest freezer is without lock.

When mounting the sliding glass lids on a cabinet with lock you must take care that notches in the bottom corner of the upper and lower lids fit together.

The notches are to be placed at the keyhole in the E-moulding.