

## FF43ESSSTBADA

32.0" x 18.75" x 20.25" (H x W x D)

ENERGY STAR qualified auto defrost refrigerator-freezer with ADA compliant counter height; black cabinet with stainless steel door and towel bar handle

### Highlights:

ENERGY STAR qualified with a more efficient system for lower energy use

32 inches high to meet ADA guidelines for lower counter height

Stainless steel door with curved towel bar handle for added luxury

Compact size with a slim 19" width fits well in hotels and offices



ENERGY STAR Qualified	Rated by the DOE to perform with more efficiency than standards require
ADA Compliant	32 inch height is designed to meet ADA guidelines for lower counter height
Automatic defrost	No-frost system simplifies maintenance in both refrigerator and freezer
Stainless steel door	Durable elegance built to last
Professional towel bar handle	A curved handle in brushed stainless steel provides generous room for a comfortable grip
Fully finished black cabinet	Allows the unit to be used freestanding
Adjustable shelves	Rearrange the refrigerator space to fit any sized item or remove shelves for simple cleanup
Crisper drawer	Get the longest life and best taste out of produce by storing greens in lower slide drawer
Door shelves	Store large bottles right on the door for easy access
Adjustable thermostat	Manage the temperature with ease and accuracy

## Specifications:

Height	32.0"
Width	18.75"
Depth	20.25"
Capacity	3.6 cu.ft.
Shipping Weight	95.0 lbs.
Voltage/Frequency	115 V AC/60 Hz
Energy Usage/Year	310.0 kWh/year
US Electrical Safety	UL
Amps	0.8
Canadian Electrical Safety	ULC
Reversible	Factory Reversible
Door Swing	RHD
Crisper Quantity	1
Shelf Quantity	2
Adjustable Shelf	true
Shelf Type	Wire
Crisper Cover Type	Glass
Crisper Finish	Transparent
Full Door Shelf Quantity	3
Defrost Type	Automatic
Height to Hinge Cap	32.5"
Thermostat Type	Dial
Freon Type	R134a
High Side PSI	235.0
Level Legs Quantity	2
Low Side PSI	140.0
Parts/Labor Warranty	1 Year
Compressor Warranty	5 Years

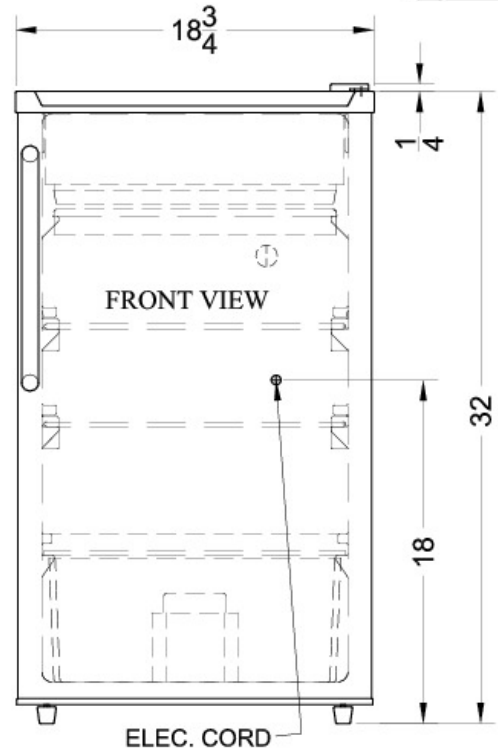
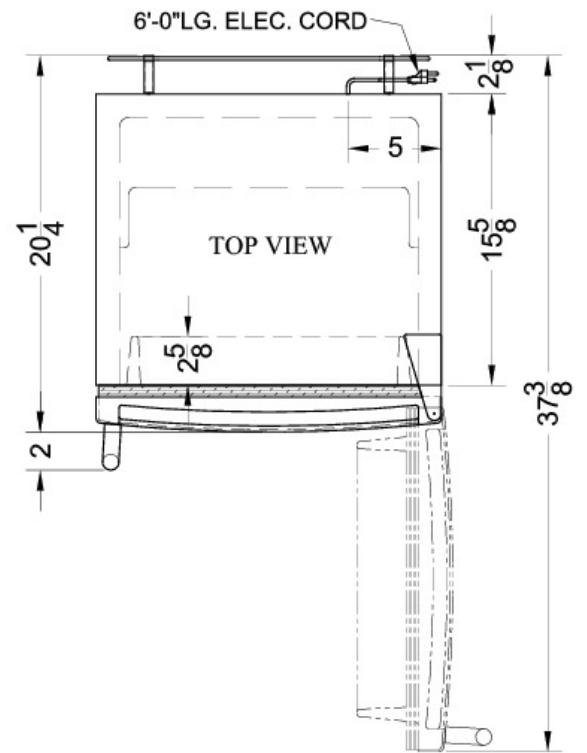

Summit Appliance Division, Felix Storch, Inc.  
 770 Garrison Ave • Bronx, NY 10474  
 Phone: 718-893-3900 • Fax: 718-842-3093  
 Email: [info@summitappliance.com](mailto:info@summitappliance.com)