

FSM50LES

33.38" x 23.75" x 25.88" (H x W x D)

Counter height all-freezer with lock and door storage

Highlights:

Factory installed lock provides security you can count on

24" width with full 4.4 cu.ft. capacity

Door shelves offer convenient storage solutions

Reversible door for added flexibility



Fully finished white cabinet	Allows the unit to be used freestanding
Factory installed lock	Keyed locks for a secure interior
Manual defrost	No temperature fluctuations with a manual defrost system that keeps the cold inside
Reversible door	User reversible door swing for added flexibility
Open shelves	Fixed shelves accommodate large items
Door shelves	Three racks for added storage options
Adjustable thermostat	Manage the interior temperature with ease and accuracy
100% CFC free	Environmentally friendly design without ozone-damaging chemicals

Specifications:

Height	33.38"
Width	23.75"
Depth	25.88"
Capacity	4.4 cu.ft.
Interior Height 1	26.0"
Interior Width 1	18.0"
Interior Depth 1	20.25"
Shipping Weight	95.0 lbs.
Weight	77.0 lbs.
Voltage/Frequency	115 V AC/60 Hz
Amps	1.0
US Electrical Safety	CSA
Energy Usage/Year	260.0 kWh/year
Canadian Electrical Safety	CSA
Reversible	Yes
Door Swing	RHD
Shelf Quantity	2
Shelf Type	Wire
Full Door Shelf Quantity	3
Defrost Type	Manual
Thermostat Type	Dial
High Side PSI	250.0
Low Side PSI	110.0
Freon Type	R134a
Level Legs Quantity	2
Freon Oz	3.35
Parts/Labor Warranty	1 Year
Compressor Warranty	5 Years

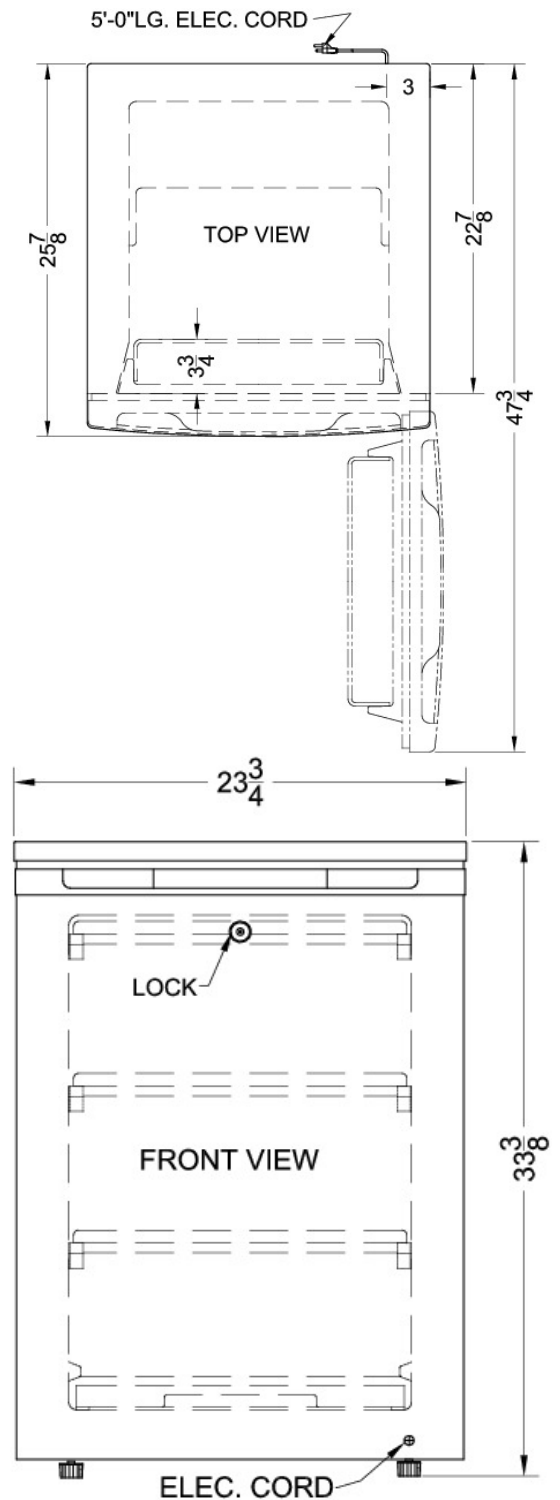

Summit Appliance Division, Felix Storch, Inc.
 770 Garrison Ave • Bronx, NY 10474
 Phone: 718-893-3900 • Fax: 718-842-3093
 Email: info@summitappliance.com