

FS22LGL7

20.5" x 17.38" x 19.0" (H x W x D)

Compact commercially listed all-freezer w/glass door and lock

Highlights:

Commercially listed to NSF-7 standards

Glass door provides full view of interior

Seamless interior liner simplifies cleanup

Factory-installed lock provides security you can count on



Commercially listed	CSA-S listed to NSF standards for commercial use
Glass door	Provides full display of stored contents
Factory installed lock	Keyed lock for a secure interior
Fully finished white cabinet	Allows the unit to be used freestanding
-20° C capable	Low temperature operation is ideal for temperature sensitive materials
Manual defrost	No temperature fluctuations with a manual defrost system that keeps the cold inside
Adjustable thermostat	Rear mounted to prevent accidental adjustments
Removable shelf	Wire shelf for storage convenience
One piece interior liner	Easy clean-up with a seamless liner that won't hold a mess in hidden crevices
Matching refrigerator available	Pair with FFAR22LGL7 for a matching countertop set

Specifications:

Height	20.5"
Width	17.38"
Depth	19.0"
Capacity	1.42 cu.ft.
Interior Height 1	14.63"
Interior Width 1	12.38"
Interior Depth 1	14.5"
Comp Step Height	7.0"
Comp Step Width	12.38"
Comp Step Depth	6.0"
Shipping Weight	55.0 lbs.
Weight	40.0 lbs.
US Electrical Safety	CSA
Amps	1.2
Voltage/Frequency	115 V AC/60 Hz
Canadian Electrical Safety	CSA
Reversible	Yes
Door Swing	RHD
Shelf Quantity	1
Shelf Type	Wire
Defrost Type	Manual
Height to Hinge Cap	20.88"
Thermostat Type	Dial
Low Side PSI	103.0
Level Legs Quantity	2
High Side PSI	270.0
Freon Type	R134a
Freon Oz	1.67
Compressor Warranty	5 Years
Parts/Labor Warranty	1 Year
Sanitation	CSA-S

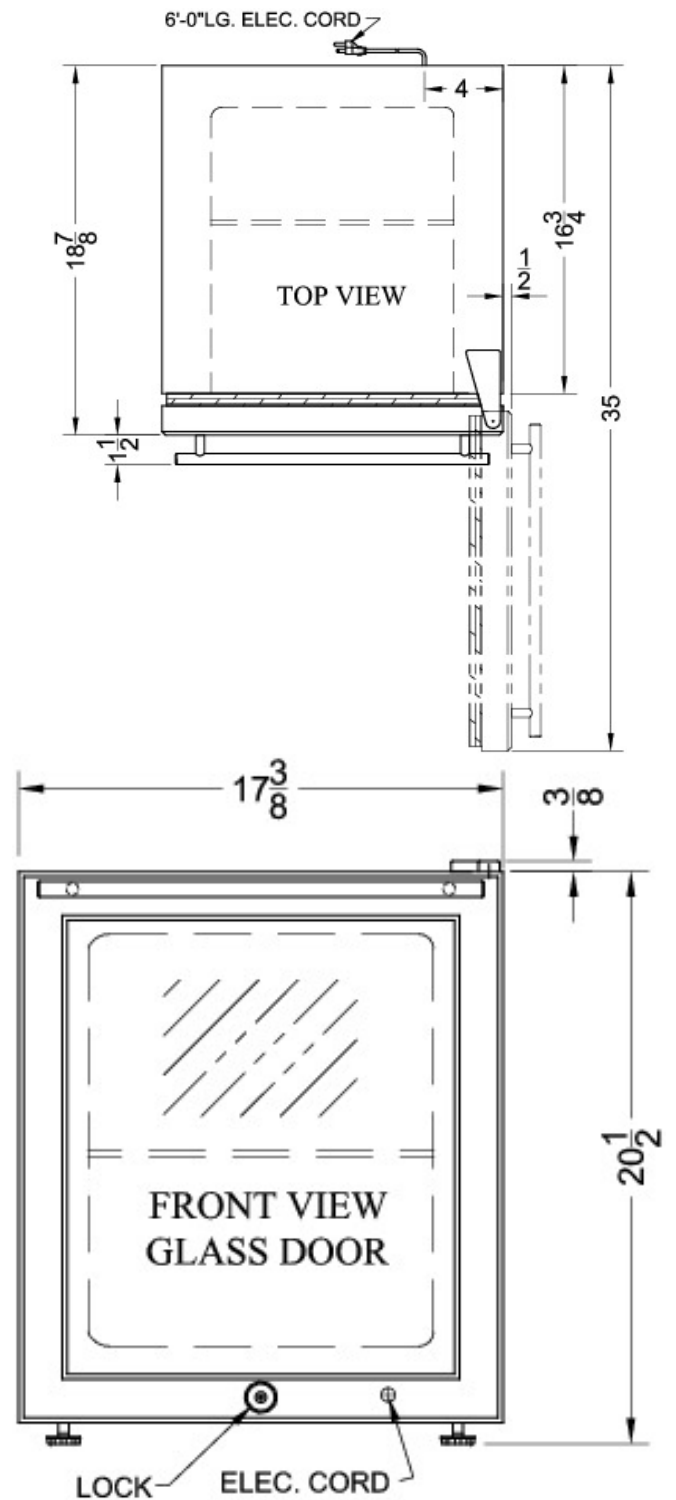

Summit Appliance Division, Felix Storch, Inc.
 770 Garrison Ave • Bronx, NY 10474
 Phone: 718-893-3900 • Fax: 718-842-3093
 Email: info@summitappliance.com