



SU45MCX

classic

60CM (approx. 24") built-in speed oven with
1000W microwave, stainless steel

EAN13: 8017709154042

10 cooking modes

Exclusive Classic design

Finger-print proof stainless steel finish

Ergonomic control knobs

Stainless steel cavity

Digital LED display

Time-setting options: Start & Stop

End of cooking time acoustic alarm

Automatic oven/microwave switch-off when door
is open

True European Convection cooking (can also be
combined with microwave)

12 5/8 size glass turntable

Temperature range 122°F – 428°F

Cooling fan

Defrost programmed by weight or by time

Microwave pizza cooking function

Child safe control lock

Microwave screen protection

1 x 20W halogen light (illuminates when door is opened)

Oven capacity: 1.20 Cu.Ft.

Microwave Power: 1850 W

Microwave effective power: 1000 W

Nominal power: 3.40 kW

Amps @ 240V: 30

Standard Accessories:

3 metal racks, 1 large grid, 1 glass tray

1 special crisp plate

Please note that this speed oven may be installed
in a wall cabinet that is a minimum of 22" wide.
Trim kits are available for wider wall cabinets.
Please contact Smeg USA sales office for further
information.



Functions



SMEG U.S.A. INC.
A&D BUILDING
150 EAST 58th STREET, 7th FLOOR
NEW YORK, NY, 10155
Tel. +1 212 265 5378
Fax +1 212 265 5945



Main Oven



European convection:

The combination of the fan and circular element around it, gives uniform heat distribution with no cold spots. This has benefits - no preheat if cook time is more than 20 minutes, no flavour transfer when cooking different foods the same time, less energy is needed, and it cooks at 10% quicker than a normal oven.



Broil + European Convection:

Broil + European Convection

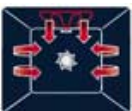

Convection broil:

Please note: cooking in this mode is conducted with the door closed. The fan reduces the fierce heat from the broiler, providing an excellent method for broiling a range of foods; chops, steaks, sausages etc. without having to turn the food during cooking. This gives good results, reduces drying out of foods, and gives even browning and heat distribution, the top two racks being recommended for use. The lower area of the cavity can also be used to keep other items warm at the same time.



Intensive broil:

This allows rapid cooking and browning of foods. Best results can be obtained from using the top rack for small items, the lower racks for larger items, such as chops or sausages. Cooking using this method should be carried out with the door closed, unless instructed to do otherwise.



Pizza function:

The simultaneous operation of these three elements ensures an optimum cooking facility, ideal not only for pizza but also for cookies, quiches and flans.



Defrost at weight:

Defrost at weight



Defrost at time:

Defrost at time



Microwave + convection:

To achieve a combined cooking with ventilated heat that cooks in short time thanks to the rotation of the warm air and the microwave.

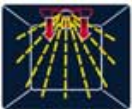

Microwave + broil element:

To achieve a combined cooking with broil that cooks the outside whilst assuring an internal cooking thanks to the microwave function.



Fan + convection + microwave:

Fan + convection + microwave



SU45MCX

classic

microwave
24"
stainless steel

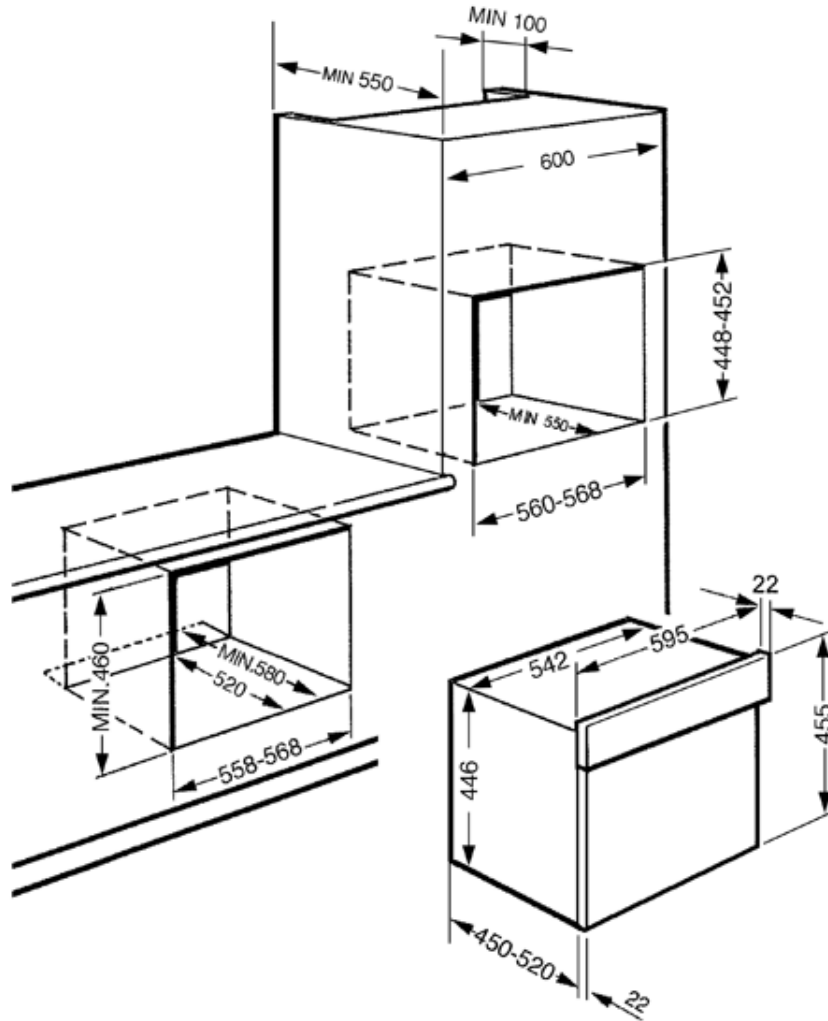

SMEG U.S.A. INC.
A&D BUILDING
150 EAST 58th STREET, 7th FLOOR
NEW YORK, NY, 10155
Tel. +1 212 265 5378
Fax +1 212 265 5945