



Standard Features & Accessories

All models include

- Total capacity—27.5 cu. ft. (779 L)
 - Refrigerator - 18.5 cu. ft.
 - Freezer - 9.0 cu. ft.
 - 84"H./24"D.
- ProChill™ Temperature Management System
 - Variable-speed DC Overdrive™ Compressor is one of the quietest, most technologically advanced compressors available
 - Electronic controls with digital temperature readouts
 - Multi-channel airflow system and Odor Eliminator™ Evaporator removes odors and excess humidity
- Exclusive Plasmacluster™* Ion Air Purifier
 - Eliminates airborne bacteria and mold spores
 - Removes odors
 - Enhances food preservation
 - Never needs replacing
- Refrigerator Compartment
 - Four adjustable tempered glass spillproof shelves
 - Adjustable Cold Zone™ drawer with precision ball-bearing glides
 - Separate temperature control can be set for produce or fresh meat storage
 - Quick chill option chills foods and beverages in minutes
 - Adjustable Humidity Zone™ drawers with precision ball-bearing glides
 - Humidity can be set high for leafy greens or low for fruits and vegetables with skins
 - Two in-the-door sealed dairy compartments with covers
 - Four patented adjustable aluminum door bins with tempered glass fronts
 - Top shelf provides quick chill-down area
- Freezer Compartment
 - Adaptive defrost
 - Three wire shelves and two slide-out baskets
 - Three patented adjustable aluminum door bins with tempered glass fronts
- Super Clog-Resistant™ Condenser is maintenance-free under normal use
- Tru-Flush™ design allows all models to fit flush into 24" deep installation cutout
- Open door alarm sounds and glows to warn that door has been ajar for three minutes
- Adjustable door stops standard—90°, 110°, or 120° swing
- Sabbath Mode

*Plasmacluster is a registered trademark of Sharp Corporation.

Model Options



VCSB5481
Professional



FDSB5481
Custom Panel

FINISH DETAILS FOR VCSB MODEL

- Stainless Steel (SS), Black (BK), White (WH), Apple Red (AR), Biscuit (BT), Burgundy (BU), Chocolate (CH), Cinnamon (CN), Cobalt Blue (CB), Cotton White (CW), Dijon (DJ), Graphite Gray (GG), Iridescent Blue (IB), Kettle Black (KB), Lemonade (LE), Mint Julep (MJ), Plum (PL), Racing Red (RR), Sage (SA), Sea Glass (SE), Stone Gray (SG), Taupe (TP), Viking Blue (VB), Wasabi (WS).
- Finish codes designate door fronts. Stainless steel upper grille, side trim, and handles (with chrome-plated brackets); black lower kickplate.
- Brass Accent Option (BR)—nameplate and handle endcaps. Brass components have a durable protective coating for maintenance-free normal use.

FINISH DETAILS FOR FDSB MODEL

- Handles not included—opt for custom handles, or purchase a Viking Professional Series handle kit (see **Installation Notes & Accessories**).
- See **Custom Panels** section for more information and additional specifications.

ORDERING INSTRUCTIONS

First specify model number, and then color code (VCSB5481**SS**). If ordering optional brass accent, specify code at end (VCSB5481**SSBR**).





REFRIGERATION

Quiet Cool™ Built-In 48"W. Side-By-Side Refrigerator/Freezer



★ Please see Installation Notes & Accessories for important information, including panel and handle kits.



ALL MODELS

Star-K Kosher Certification for use on the Jewish Sabbath or Jewish holidays

Dimensions & Specifications

PRODUCT DIMENSIONS



VCSB5481 Professional

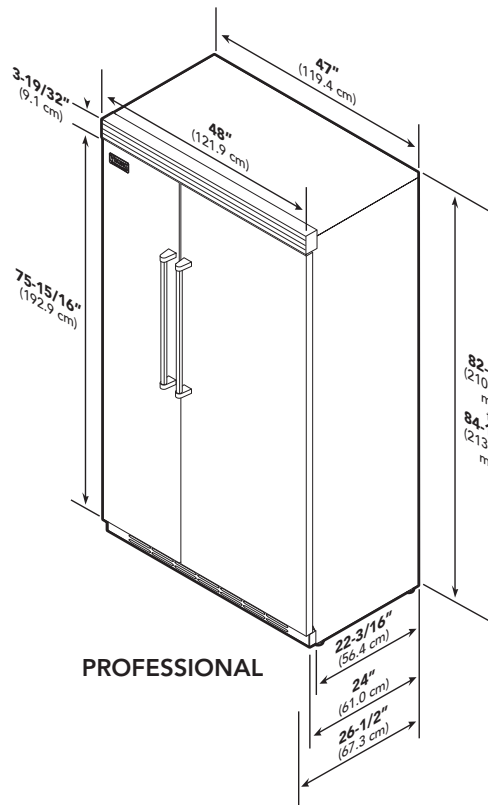

PROFESSIONAL

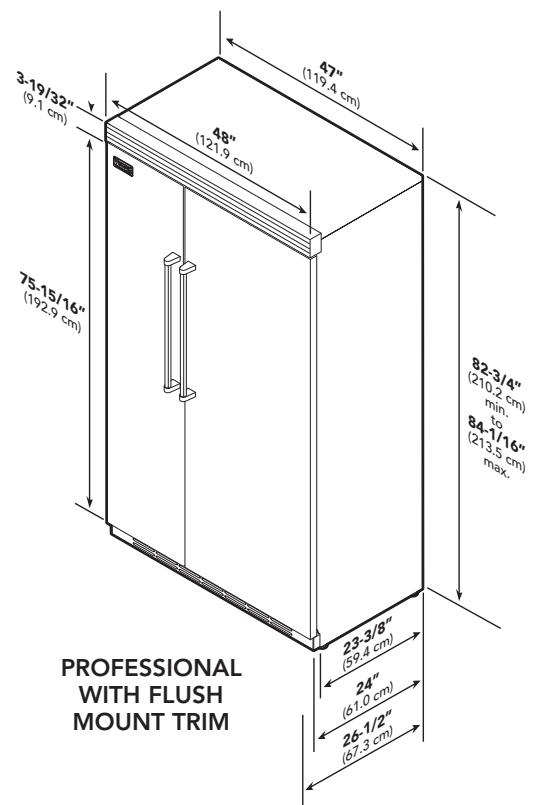

PROFESSIONAL WITH FLUSH MOUNT TRIM

	VCSB5481	VCSB5481/Flush Mount
Overall width	48" (121.9 cm)	
Overall height (from bottom)	82-3/4" (210.2 cm) min. to 84-1/16" (213.5 cm) max.	
Overall depth (from rear)		
To front edge of side trim	22-3/16" (56.4 cm)	23-3/8" (59.4 cm)
To front of top grille	24" (61.0 cm)	24" (61.0 cm)
To front of handle	26-1/2" (67.3 cm)	26-1/2" (67.3 cm)
Approx. ship weight	715 lbs. (321.8 kg)	





REFRIGERATION

Quiet Cool™ Built-In 48"W. Side-By-Side Refrigerator/Freezer



★ Please see Installation Notes & Accessories for important information, including panel and handle kits.



Star-K Kosher Certification for use on the Jewish Sabbath or Jewish holidays

Dimensions & Specifications

PRODUCT DIMENSIONS



FDSB5481 Custom Panel

See Custom Panels section for more information and additional specifications.

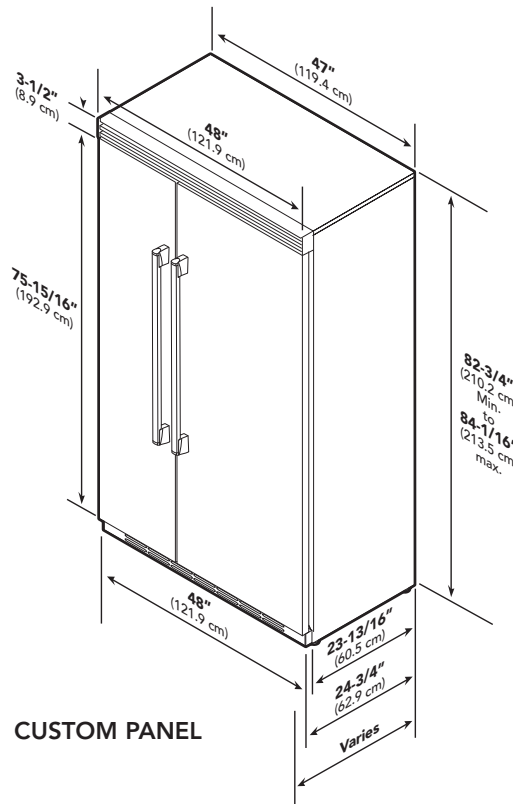

CUSTOM PANEL

FDSB5481	
Overall width	48" (121.9 cm)
Overall height (from bottom)	82-3/4" (210.2 cm) min. to 84-1/16" (213.5 cm) max.
Overall depth (from rear)	
To front edge of side trim	23-13/16" (60.5 cm)
To front of top grille	24-3/4" (62.9 cm)
To front of handle	Varies
Approx. ship weight	650 lbs. (292.5 kg)





REFRIGERATION

Quiet Cool™ Built-In 48"W. Side-By-Side Refrigerator/Freezer



Dimensions & Specifications

CLEARANCE DIMENSIONS—PROFESSIONAL

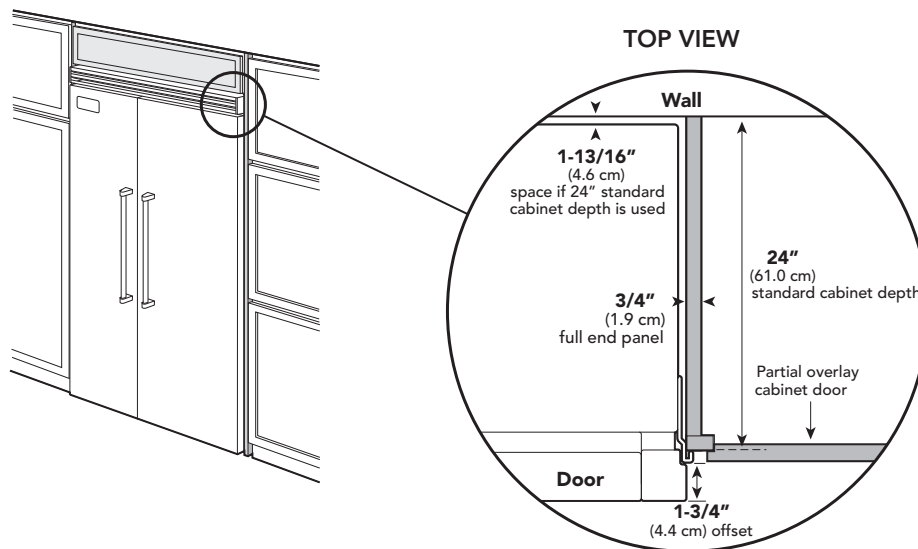
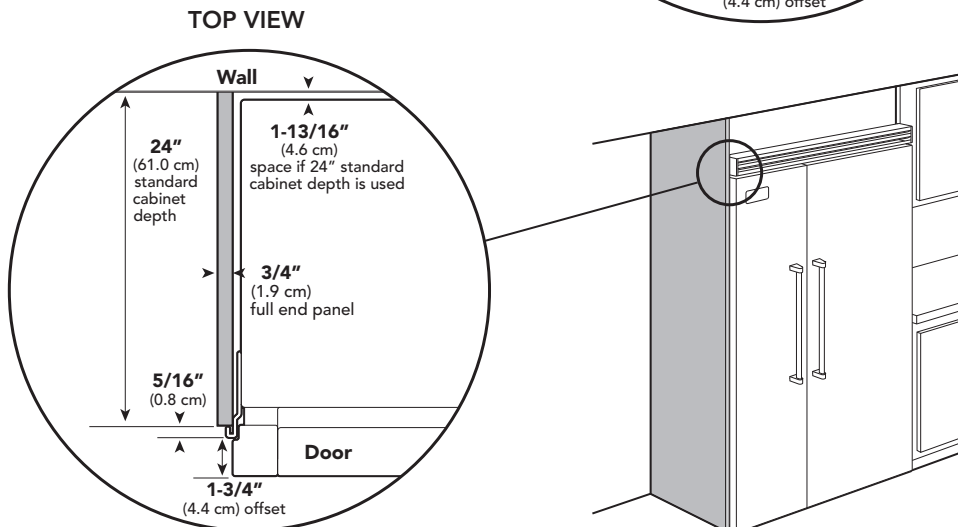
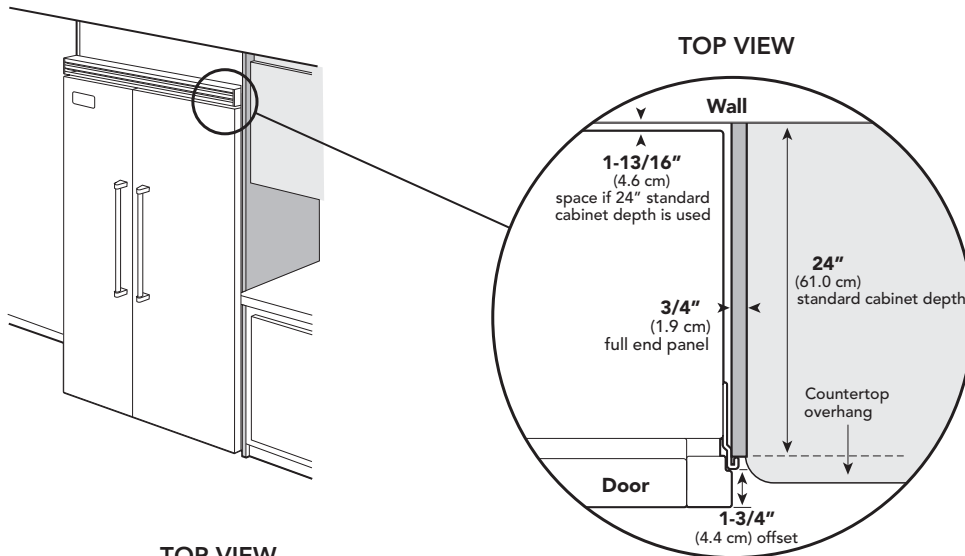



REFRIGERATION

Quiet Cool™ Built-In 48" W. Side-By-Side Refrigerator/Freezer



Dimensions & Specifications

CLEARANCE DIMENSIONS—PROFESSIONAL WITH FLUSH MOUNT TRIM

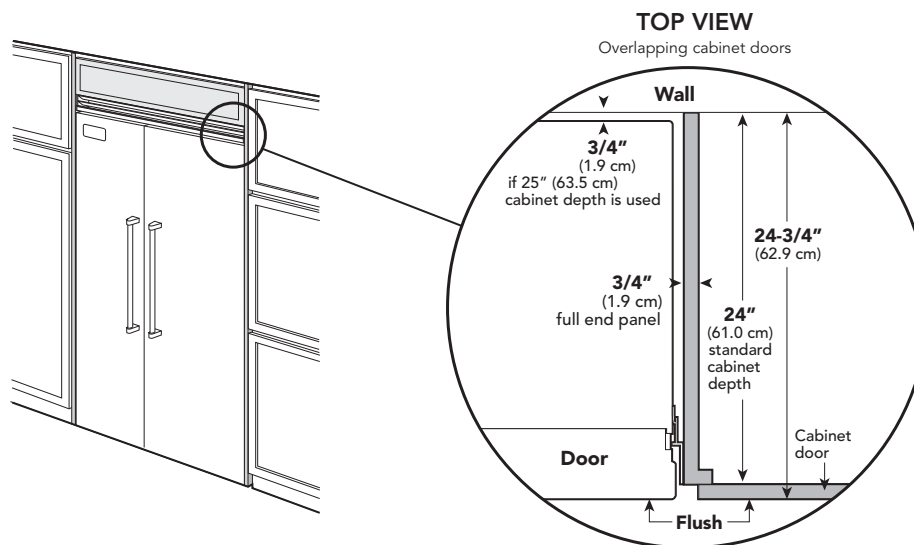
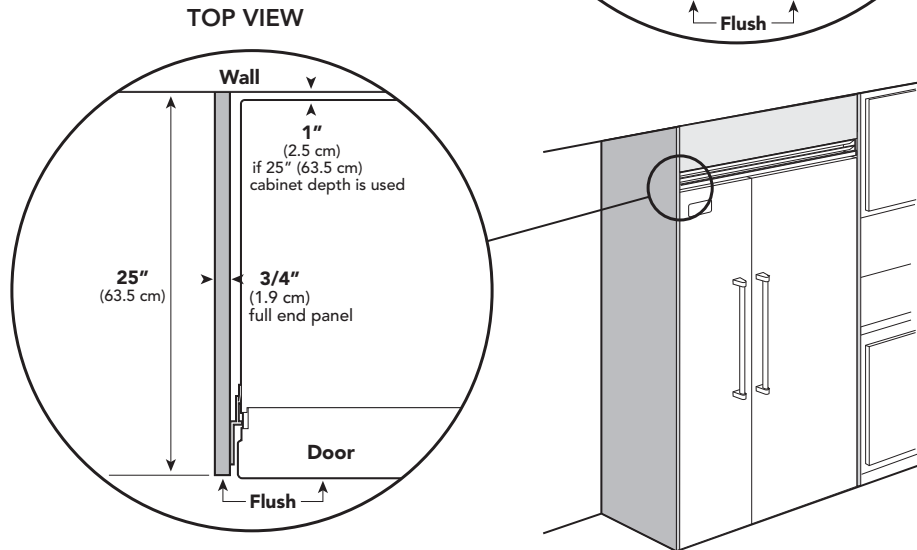
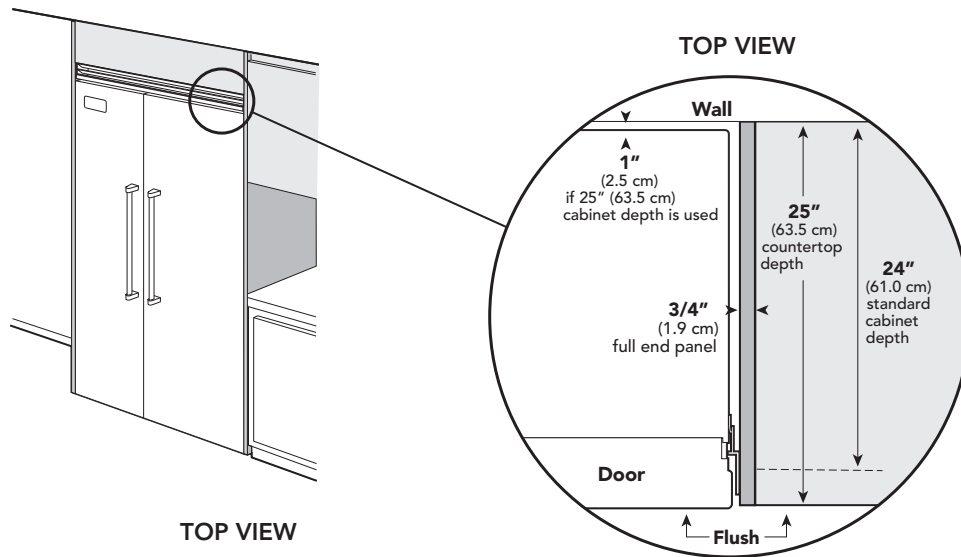



REFRIGERATION

Quiet Cool™ Built-In 48" W. Side-By-Side Refrigerator/Freezer



UTILITY REQUIREMENTS



GAS
Not applicable



- ELECTRICAL**
- Three-wire cord with grounded three-prong plug attached to product
 - 115 VAC/60 Hz; 15 amp dedicated circuit
 - Maximum amp usage—9.9
 - Estimated energy usage—670 kWh/year



- PLUMBING**
- Inlet waterline requirements—1/4" copper tubing
 - 20 psi min.; 120 psi max.

Installation Requirements

ACCESS REQUIREMENTS



VCSB5481
Professional



FDSB5481
Custom Panel

See **Custom Panels** section for more information and additional specifications.

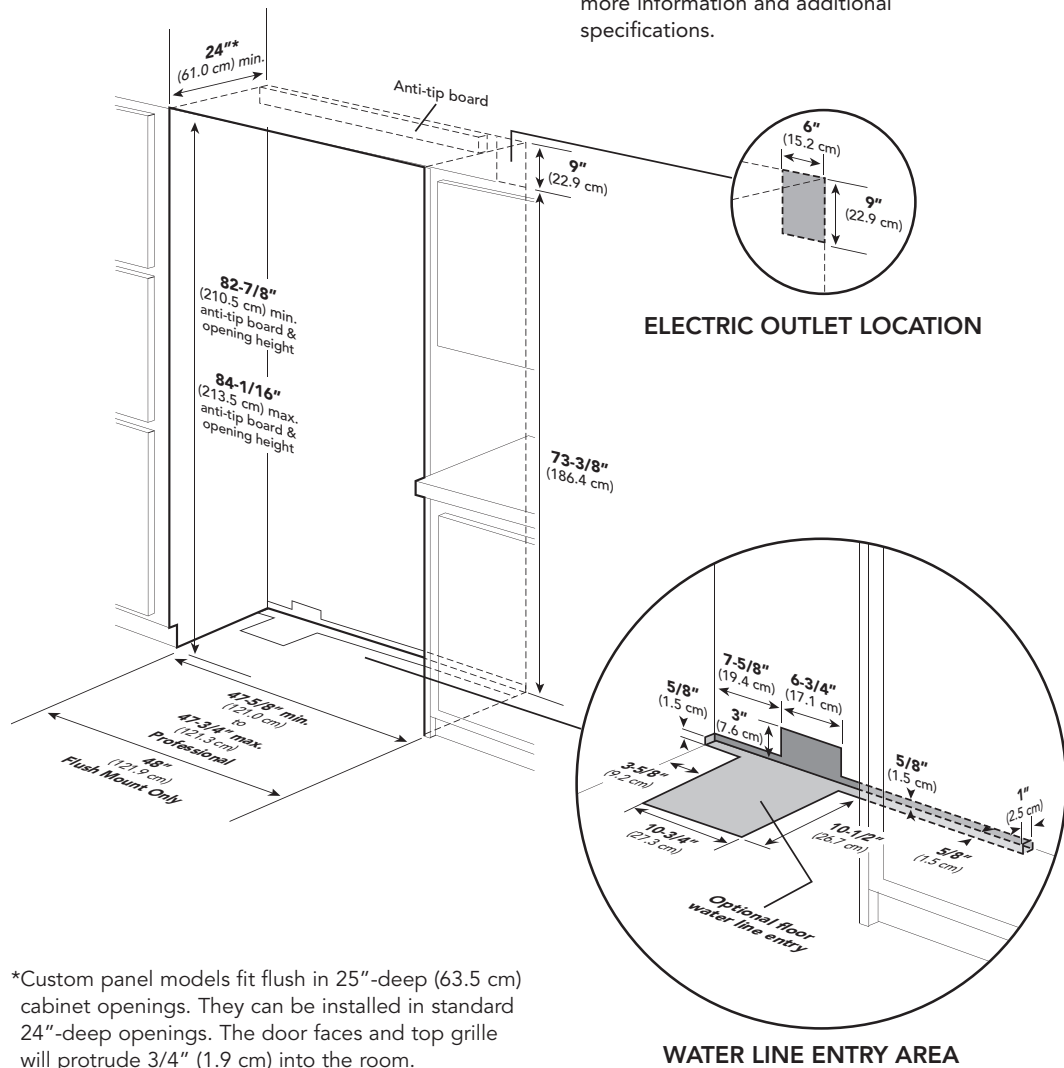

*Custom panel models fit flush in 25"-deep (63.5 cm) cabinet openings. They can be installed in standard 24"-deep openings. The door faces and top grille will protrude 3/4" (1.9 cm) into the room.

	VCSB5481	VCSB5481/Flush Mount	FDSB5481
Cutout width	47-5/8" (121.0 cm) min. to 47-3/4" (121.3 cm) max.	48" (121.9 cm)	48" (121.9 cm)
Cutout height	82-7/8" (210.5 cm) min. to 84-1/16" (213.5 cm) max.		
Cutout depth	24" (61.0 cm) min.*		





REFRIGERATION

Quiet Cool™ Built-In 48"W. Side-By-Side Refrigerator/Freezer



★ Installation Notes & Accessories

Side Panel Kits

- Stainless Steel (SS)
- Panels provide finished, freestanding look; unit must still be secured to the wall
- Kit includes one panel and installation hardware

Model	Description	Approx. ship wt. lbs. (kg)
PSSPL2	Professional side panel left - Standard Mount	45 (20.2)
PSSPR2	Professional side panel right - Standard Mount	45 (20.2)
DSSPL2	Designer side panel left - Flush Mount	45 (20.2)
DSSPR2	Designer side panel right - Flush Mount	45 (20.2)

Side Panel Hardware Kit

- For use with custom panel built-in refrigerator/freezers
- Hardware allows installation of custom side panels
- Kit includes brackets, screws, and installation instructions to mount panels on left and right side

Model	Description	Approx. ship wt. lbs. (kg)
SPHKDS	Side panel hardware	3 (1.4)

Top Panel Kit

- Stainless Steel (SS)
- Panel provides finished, freestanding look; unit must still be secured to the wall
- Kit includes one panel and installation hardware

Model	Description	Approx. ship wt. lbs. (kg)
TOP-48	48"W. top panel	24 (10.8)

Handle Kits

- For use with custom panel refrigerator/freezers
- For use on locally supplied custom panels
- Handles allow refrigerator/freezers with custom panels to coordinate with other Professional products
- Kit includes two handles and installation hardware

Model	Description	Approx. ship wt. lbs. (kg)
PHK-DFSB5-SS	Professional handles (Stainless Steel)	10 (4.5)

Compliance Information



WARRANTY SUMMARY*

- Three-year full warranty—complete unit
- Six-year full warranty—sealed refrigeration system
- Twelve-year limited warranty—sealed refrigeration system (includes compressor, condenser, dryer/strainer, evaporator, and connecting tubing)
- Ninety-day limited warranty—cosmetic parts such as glass, painted, and decorative items

*For complete warranty see *Use & Care Guide*. Warranty valid on Viking products shipped within the United States and Canada.

