

MRF40B

43.63" x 18.75" x 18.63" (H x W x D)

Compact refrigerator-freezer-microwave combination in slim width and black exterior

Highlights:

Refrigerator-freezer with touchpad microwave fully assembled in one piece

Less than 19" wide

Allocator box limits power consumption for safer use

All black exterior



Thin-line design	Just under 19" wide for an easy fit in any tight spot
CM40B refrigerator-freezer	Manual defrost with a drop-down freezer cover
SUMMIT SM902BL microwave	Touchpad controls with one-touch cook options
Allocator box	Plug the refrigerator, microwave, and a third appliance into this allocator box for safe operation that limits total power consumption to 10 amps
Reversible door	Keep your options flexible with a reversible door on the refrigerator
Ships fully assembled in one box	No assembly required before use
100% CFC Free	Environmentally friendly design with no ozone-damaging chemicals

Specifications:

Height	43.63"
Width	18.75"
Depth	18.63"
Capacity	3.9 cu.ft.
US Electrical Safety	UL
Voltage/Frequency	115 V AC/60 Hz
Reversible	Yes
Door Swing	RHD
Shelf Quantity	3
Shelf Type	Wire
Crisper Cover Type	Glass
Full Door Shelf Quantity	1
Half Door Shelf Quantity	2
Defrost Type	Manual
Depth with door at 90°	36.5"
Digital Display	true
Specialized Cooking Buttons	true
Control Pad Type	Digital
Condensor Location	Rear of Unit
Thermostat Type	Dial
Freon Type	R134a
Level Legs Quantity	2
Parts/Labor Warranty	1 Year
Compressor Warranty	5 Years

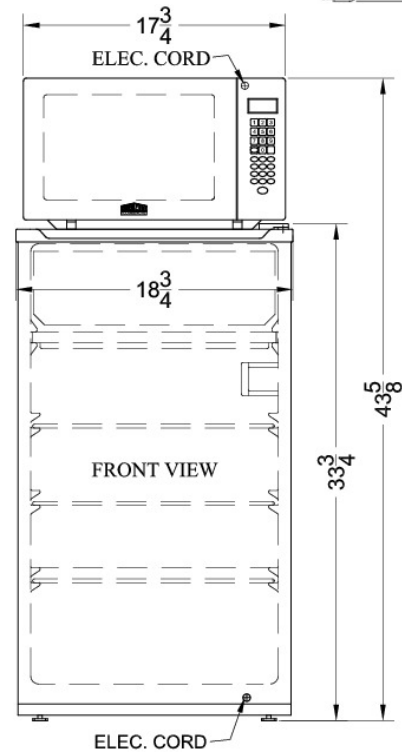
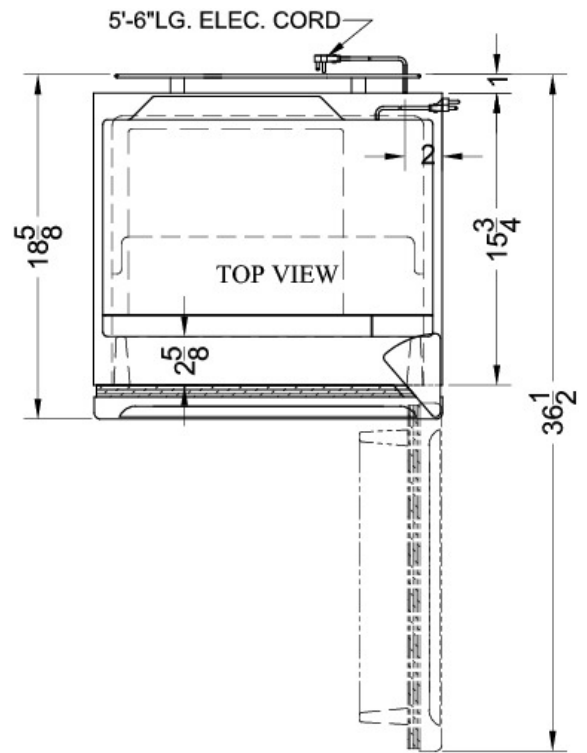

Summit Appliance Division, Felix Storch, Inc.
 770 Garrison Ave • Bronx, NY 10474
 Phone: 718-893-3900 • Fax: 718-842-3093
 Email: info@summitappliance.com