



REFRIGERATION

Undercounter/Freestanding 24"W. Refrigerator



Standard Features & Accessories

All models include

- Electronic controls with digital temperature readout
 - Inside temperature can be adjusted from 33 – 39°F
 - Factory set at 34°F
 - Sabbath mode
 - Temperature can be displayed in either Fahrenheit or Celsius
- Capacity—5.3 cu. ft. (150.0 L)
- Two full-extension wire shelves
 - 75 lbs. capacity
 - Removable and adjustable
- Dual pane and argon-filled Low-E energy efficient glass doors
- LED display lighting
- Forced air cooling system with powerful 700 BTU compressor
- Tru-Flush™ design allows unit to fit flush in 24" deep cutout
- Energy Star qualified
- Undercounter or freestanding installation
- Self-closing door
- Super quiet 32-39 db sound rating
- Black kickplate
- Adjustable leveling legs
- Must be ordered right or left hinge (As you face unit, RIGHT has hinge on right side and handle on left side; LEFT has hinge on left side and handle on right side.)

Model Options



VRCI1240G
Professional

- FINISH DETAILS FOR VRCI MODELS**
- Clear glass doors
 - Stainless Steel (SS)—stainless steel frame around large window door, stainless steel handle with chrome-plated brackets, and stainless steel exterior cabinet.
 - Stainless steel interior



FRCI1240G
Custom Panel

- FINISH DETAILS FOR FRCI MODELS**
- Clear glass doors.
 - Stainless steel interior
 - Handle not included—opt for custom handle, or purchase a Viking Professional Series handle kit (see **Installation Notes & Accessories**).
 - Accepts 3/4"-thick custom wood frame.
 - See **Custom Panels** section for more information and additional specifications.

ORDERING INSTRUCTIONS

First specify model number, then specify hinge preference ("R" for right or "L" for left), and then color code (VRCI1240GRSS).





REFRIGERATION

Undercounter/Freestanding 24"W. Refrigerator



★ Please see
Installation Notes &
Accessories
for important
information,
including handle
kits.

Dimensions & Specifications

PRODUCT DIMENSIONS



VRCI1240G
Professional



FRCI1240G
Custom Panel

See **Custom Panels** section for
more information and additional
specifications.

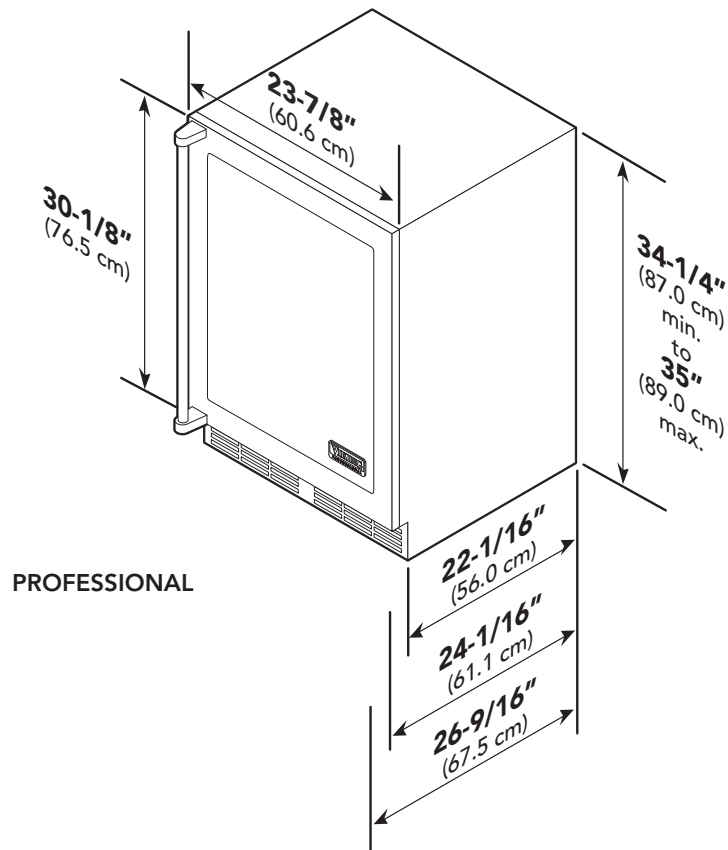

| | VRCI1240G | FRCI1240G |
|---------------------------|---|------------------|
| Overall width | 23-7/8" (60.6 cm) | |
| Overall height | 34-1/4" (87.0 cm) min. to 35" (89.0 cm) max. | |
| Overall depth (from rear) | | |
| To front of handle | 26-9/16" (67.5 cm) | Varies |
| Approx. ship weight | 215 lbs. (98.0 kg) | |





REFRIGERATION

Undercounter/Freestanding 24"W. Refrigerator



Dimensions & Specifications

DOOR SWING



VRCI1240G
Professional



FRCI1240G
Custom Panel

See **Custom Panels** section for more information and additional specifications.

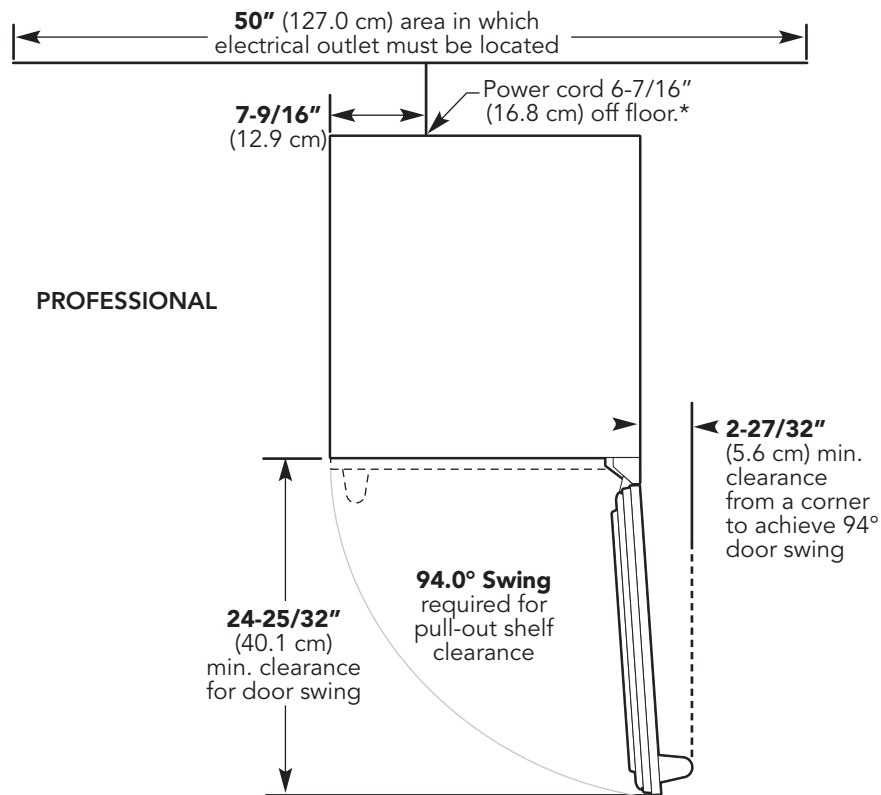



REFRIGERATION

Undercounter/Freestanding 24"W. Refrigerator



UTILITY REQUIREMENTS



GAS
Not applicable



ELECTRICAL

- Three-wire cord with grounded three-prong plug attached to product
- 115V/60 Hz; 15 amp dedicated circuit
- Maximum amp usage—3.0



PLUMBING
Not applicable

Installation Requirements

ACCESS REQUIREMENTS



VRCI1240G
Professional



FRCI1240G
Custom Panel

See **Custom Panels** section for more information and additional specifications.

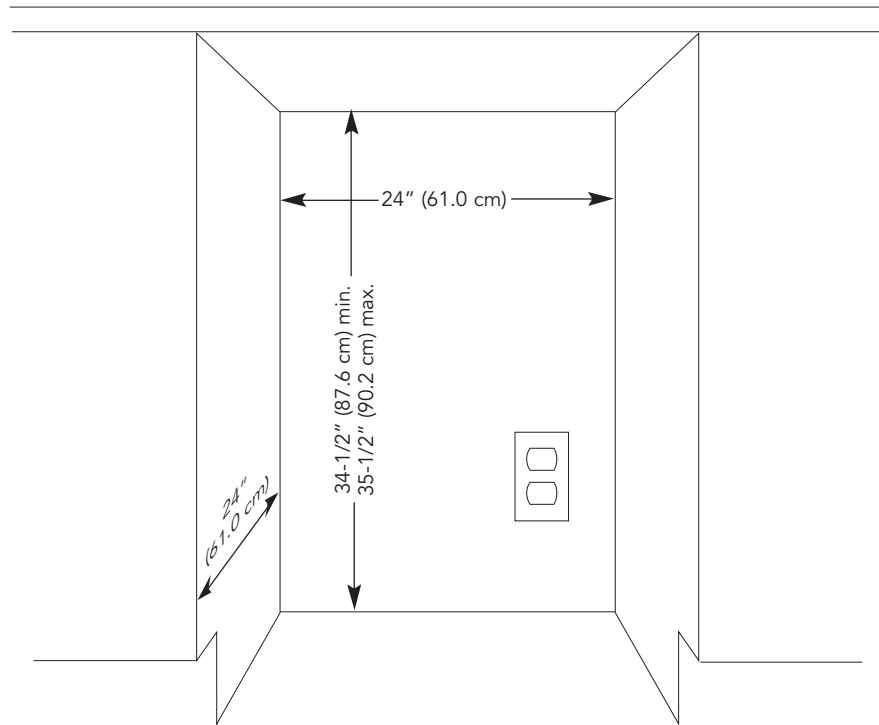

All models

| | |
|---------------|--|
| Cutout width | 24" (61.0 cm) |
| Cutout height | 34-1/2" (87.6 cm) min. to 35-1/2" (90.2 cm) max. |
| Cutout depth | 24" (61.0 cm) |





REFRIGERATION

Undercounter/Freestanding 24"W. Refrigerator



★ Installation Notes & Accessories

Handle Kits

- For use with custom panel 24"W. refrigerator
- For use on locally supplied custom panels
- Handles allow custom panel products to coordinate with other Professional products
- Kit includes one handle and installation hardware

| Model | Description | Approx. ship wt. lbs. (kg) |
|----------|---------------------------------------|----------------------------|
| PHK30-SS | Professional handle (Stainless Steel) | 6 (2.7) |

Compliance Information



WARRANTY SUMMARY*

- Three-year full warranty—complete unit
- Six-year full warranty—sealed refrigeration system (includes compressor, condenser, dryer/strainer, evaporator, and connecting tubing)
- Twelve-year limited warranty—sealed refrigeration system
- Ninety-day limited warranty—cosmetic parts such as glass, painted items, and decorative items

*For complete warranty see *Use & Care Guide*. Warranty valid on Viking products shipped within the United States and Canada.

