



OUTDOOR—REFRIGERATION

Undercounter/Freestanding 24"W. Refrigerated Drawer



Standard Features & Accessories

All models include

- Agency certified for outdoor use
- Electronic controls with digital temperature readout
 - Inside temperature can be adjusted from 33 – 39°F
 - Factory set at 34°F
 - Sabbath mode
 - Temperature can be displayed in either Fahrenheit or Celsius
- Capacity—5.3 cu. ft. (150.0 L)
- 200 lb. capacity full-extension drawer glides
- LED display lighting
- Forced air cooling system with powerful 700 BTU compressor
- Tru-Flush™ design allows unit to fit flush in 24" deep cutout
- Energy Star qualified
- Undercounter or freestanding installation
- Self-closing door with keyed lock
- Super quiet 32-39 db sound rating
- Stainless steel kickplate
- Adjustable leveling legs

Model Options



**VRDO1240D
Professional**

FINISH DETAILS FOR VRDO MODEL

- Solid door—Stainless Steel (SS)
- Finish code designates drawer fronts. Stainless steel handle with chrome-plated brackets, stainless steel exterior cabinet, and stainless steel interior.





OUTDOOR—REFRIGERATION

Undercounter/Freestanding 24"W. Refrigerated Drawer



★ Please see
Installation Notes &
Accessories
for important
information,
including pan sets
and dividers.

Dimensions & Specifications

PRODUCT DIMENSIONS



VRDO1240D
Professional

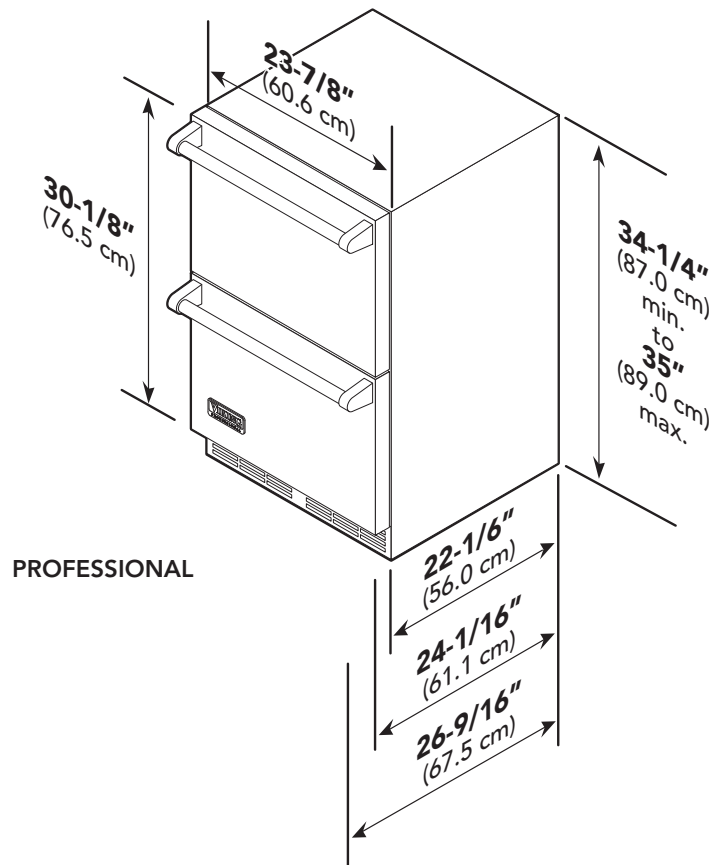

VRDO1240D	
Overall width	23-7/8" (60.6 cm)
Overall height	34-1/4" (87.0 cm) min. to 35" (89.0 cm) max.
Overall depth (from rear)	
To front edge of handle	22-1/16" (56.0 cm)
With drawer fully extended	24-1/16" (61.1 cm)
Approx. ship wt.	215 lbs. (98.0 kg)





OUTDOOR—REFRIGERATION

Undercounter/Free-standing
24"W. Refrigerated Drawer



Dimensions & Specifications

DRAWER EXTENSION



VRDO1240D
Professional

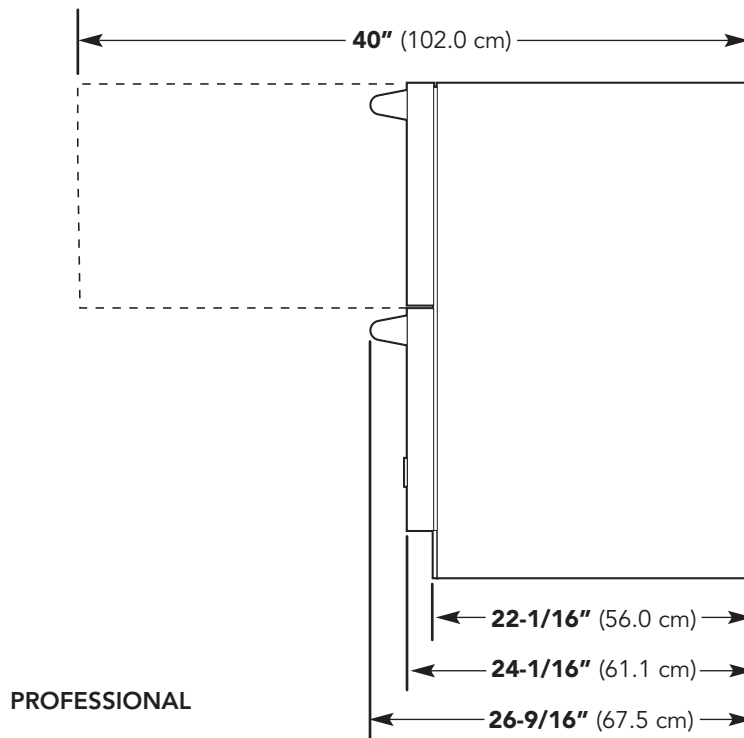



OUTDOOR—REFRIGERATION

Undercounter/Freestanding 24"W. Refrigerated Drawer



UTILITY REQUIREMENTS



GAS

Not applicable



ELECTRICAL

- Three-wire cord with grounded three-prong plug attached to product
- 115V/60 Hz; 15 amp dedicated circuit
- Maximum amp usage—3.0



PLUMBING

Not applicable

Installation Requirements

ACCESS REQUIREMENTS



VRDO1240D
Professional

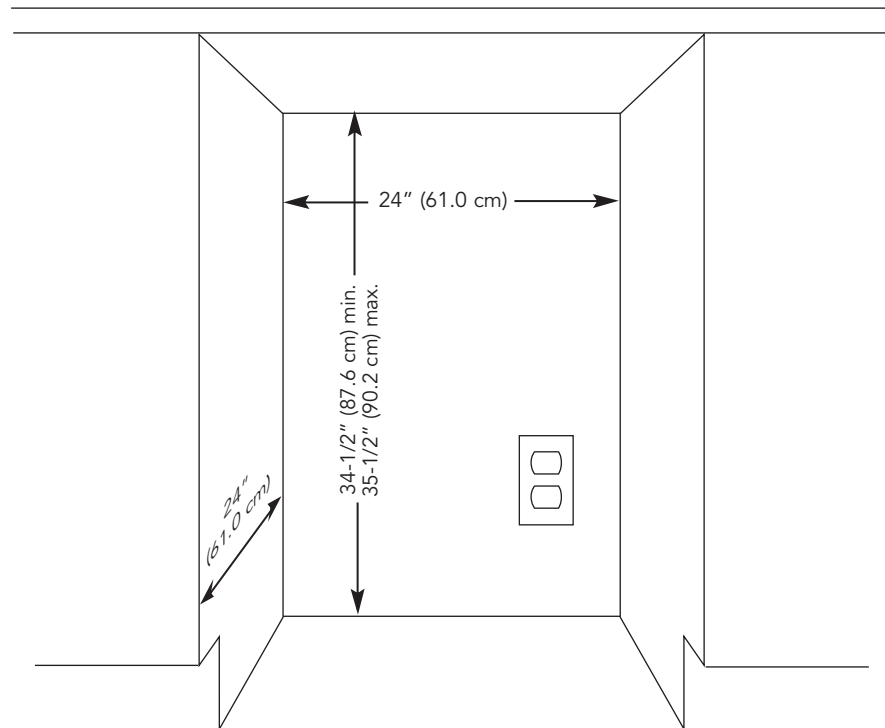

All models

Cutout width	24" (61.0 cm)
Cutout height	34-1/2" (87.6 cm) min. to 35-1/2" (90.2 cm) max.
Cutout depth	24" (61.0 cm)





OUTDOOR—REFRIGERATION

Undercounter/Freestanding 24"W. Refrigerated Drawer



★ Installation Notes & Accessories

Stainless Steel Cabinetry-Bases

- Stainless Steel (SS)
- For use with 24"W. Viking outdoor refrigeration products
- See individual product pages (storage section) for more information and additional specifications

Model	Description	Approx. ship wt. lbs. (kg)
VURO3200	Base for 24"W outdoor refrigerated drawer	125 (56.7)

Stainless Steel Cabinetry-Oven Towers

- Stainless Steel (SS)
- For installation of 24" refrigerated drawer with oven
- See individual product pages (storage section) for more information and additional specifications

Model	Description	Approx. ship wt. lbs. (kg)
VERO3200	32"W. tower (for 24"W. refrigerated drawer + smoker oven)	271 (122.9)
VGRO3200	32"W. tower (for 24"W. refrigerated drawer + gas oven)	271 (122.9)

Compliance Information



WARRANTY SUMMARY*

- One-year full warranty—complete unit
- Five-year limited warranty—sealed refrigeration system (includes compressor, condenser, dryer/strainer, evaporator and connecting tubing)
- Ninety-day limited—cosmetic parts such as glass, painted, and decorative items

*For complete warranty, see *Use & Care Guide*. Warranty valid on Viking products shipped within the United States and Canada.

